

OPERATING AND SERVICE MANUAL

5335A Universal Frequency Counter

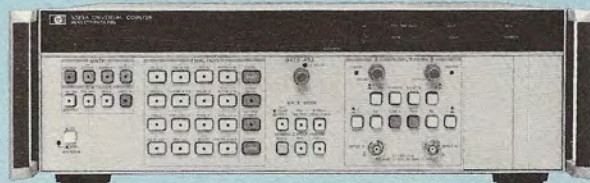

General Information
Installation
Operation and Programming
Performance Tests
Adjustments
Replaceable Parts
Manual Changes
Service



CERTIFICATION

Hewlett-Packard Company certifies that this product met its published specifications at the time of shipment from the factory. Hewlett-Packard further certifies that its calibration measurements are traceable to the United States National Bureau of Standards, to the extent allowed by the Bureau's calibration facility, and to the calibration facilities of other International Standards Organization members.

WARRANTY

This Hewlett-Packard instrument product is warranted against defects in material and workmanship for a period of one year from date of shipment. During the warranty period, Hewlett-Packard Company will, at its option, either repair or replace products which prove to be defective.

For warranty service or repair, this product must be returned to a service facility designated by HP. Buyer shall prepay shipping charges to HP and HP shall pay shipping charges to return the product to Buyer. However, Buyer shall pay all shipping charges, duties, and taxes for products returned to HP from another country.

HP warrants that its software and firmware designated by HP for use with an instrument will execute its programming instructions when properly installed on that instrument. HP does not warrant that the operation of the instrument, or software, or firmware will be uninterrupted or error free.

LIMITATION OF WARRANTY

The foregoing warranty shall not apply to defects resulting from improper or inadequate maintenance by Buyer, Buyer-supplied software or interfacing, unauthorized modification or misuse, operation outside of the environmental specifications for the product, or improper site preparation or maintenance.

NO OTHER WARRANTY IS EXPRESSED OR IMPLIED. HP SPECIFICALLY DISCLAIMS THE IMPLIED WARRANTIES OF MERCHANTABILITY AND FITNESS FOR A PARTICULAR PURPOSE.

EXCLUSIVE REMEDIES

THE REMEDIES PROVIDED HEREIN ARE BUYER'S SOLE AND EXCLUSIVE REMEDIES. HP SHALL NOT BE LIABLE FOR ANY DIRECT, INDIRECT, SPECIAL, INCIDENTAL, OR CONSEQUENTIAL DAMAGES, WHETHER BASED ON CONTRACT, TORT, OR ANY OTHER LEGAL THEORY.

ASSISTANCE

Product maintenance agreements and other customer assistance agreements are available for Hewlett-Packard products.

For any assistance, contact your nearest Hewlett-Packard Sales and Service Office. Addresses are provided at the back of this manual.

OPERATING AND SERVICE MANUAL

5335A UNIVERSAL FREQUENCY COUNTER

SERIAL PREFIX: 2232A

This manual applies to Serial Prefix 2224A, unless accompanied by a Manual Change Sheet indicating otherwise.

OLDER INSTRUMENTS

For serial prefix below 2232A, refer to Section VII for manual backdating.

First Edition — April 1980
Second Edition — October 1980
Third Edition — March 1983
Fourth Edition — August 1988

© Copyright 1980
by
HEWLETT-PACKARD COMPANY
5301 Stevens Creek Boulevard
Santa Clara, California 95052

All Rights Reserved

MANUAL PART NUMBER 05335-90021
Microfiche Part Number 05335-90022



TABLE OF CONTENTS

| Section | Title | Page |
|---------|--|------|
| I | GENERAL INFORMATION | 1-1 |
| | 1-1. Introduction | 1-1 |
| | 1-3. Manual Summary | 1-1 |
| | 1-5. Specifications | 1-1 |
| | 1-7. Safety Considerations | 1-1 |
| | 1-9. Instrument Identification | 1-1 |
| | 1-11. Accessories | 1-1 |
| | 1-13. Description | 1-5 |
| | 1-17. Options | 1-5 |
| | 1-19. Recommended Test Equipment | 1-5 |
| II | INSTALLATION | 2-1 |
| | 2-1. Introduction | 2-1 |
| | 2-3. Unpacking and Inspection | 2-1 |
| | 2-5. Preparation for Use | 2-1 |
| | 2-6. Power Requirements | 2-1 |
| | 2-8. Line Voltage Selection | 2-1 |
| | 2-14. Power Cable | 2-2 |
| | 2-16. Operating Environment | 2-2 |
| | 2-19. HP-IB Interconnections | 2-2 |
| | 2-22. 5335A HP-IB Address | 2-4 |
| | 2-24. HP-IB Descriptions | 2-4 |
| | 2-26. Field Installation of Options | 2-4 |
| | 2-28. Field Installation of Option 010 | 2-4 |
| | 2-30. Field Installation Procedures for Option 020 | 2-4 |
| | 2-32. Field Installation Procedures for Option 030 | 2-5 |
| | 2-35. Field Installation Procedures for Option 040 | 2-6 |
| | 2-37. Storage and Shipment | 2-8 |
| | 2-38. Environment | 2-8 |
| | 2-41. Packaging | 2-8 |
| III | OPERATION AND PROGRAMMING | 3-1 |
| | 3-1. Introduction | 3-1 |
| | 3-4. Operating Characteristics | 3-1 |
| | 3-7. Local Operation | 3-1 |
| | 3-10. Remote Operation | 3-1 |
| | 3-12. Operator's Self-Check Procedure | 3-2 |
| | 3-14. General Operation Information | 3-2 |
| | 3-15. Power-Up/Self-Check | 3-2 |
| | 3-19. Display | 3-2 |
| | 3-26. Keyboard | 3-3 |
| | 3-28. Key Indicators | 3-3 |
| | 3-30. Keyboard Memory | 3-3 |
| | 3-33. Key Default | 3-3 |
| | 3-35. Special Function Mode | 3-4 |
| | 3-38. Front Panel Features | 3-4 |
| | 3-41. Function Group | 3-4 |
| | 3-48. Gate/Cycle Group | 3-5 |
| | 3-56. Input Group (Standard Instrument) | 3-6 |
| | 3-62. Input Group (Option 040) | 3-6 |

TABLE OF CONTENTS (Continued)

| Section | Title | Page |
|---------|---|------|
| III | OPERATION AND PROGRAMMING (Continued) | |
| 3-74. | Triggering (MANUAL/AUTO) | 3-7 |
| 3-82. | Math Group | 3-8 |
| 3-91. | Statistics Group | 3-10 |
| 3-96. | Input C (Option 030) | 3-11 |
| 3-98. | Volts (Option 020) | 3-11 |
| 3-100. | Rear Panel Features | 3-12 |
| 3-106. | Detailed Operating Instructions | 3-13 |
| 3-108. | FREQ A (Channel A Frequency) | 3-13 |
| 3-115. | TIME A→B (Time Interval A to B) | 3-15 |
| 3-122. | TOT A (A Channel Events Totalized) | 3-16 |
| 3-128. | RATIO A/B (Ratio of Frequencies of Channel A Signal to Channel B Signal) | 3-17 |
| 3-130. | FREQ C | 3-17 |
| 3-132. | 1/TIME A→B | 3-17 |
| 3-135. | PULSE A | 3-17 |
| 3-138. | RATIO C/A | 3-18 |
| 3-140. | PER A (Channel A Period Measurement) | 3-18 |
| 3-142. | RISE/FALL A (Channel A Rise and Fall Time Measurement) .. | 3-18 |
| 3-144. | SLEW A | 3-18 |
| 3-146. | DUTY CYC A (Channel A Duty Cycle Measurement) | 3-19 |
| 3-150. | GATE TIME | 3-19 |
| 3-154. | TRIG LVL (Trigger Level) | 3-19 |
| 3-157. | VOLTS | 3-19 |
| 3-160. | PHASE A rel B | 3-20 |
| 3-164. | Special Functions | 3-21 |
| 3-167. | Programming | 3-22 |
| 3-168. | Introduction | 3-22 |
| 3-171. | Interface Function | 3-22 |
| 3-175. | Bus Messages | 3-23 |
| 3-177. | Address Selection | 3-25 |
| 3-181. | Device Command Definitions | 3-26 |
| 3-183. | Programming 5335A Option 040 | 3-27 |
| 3-185. | Trigger Level Setting TR, AT, BT | 3-27 |
| 3-187. | The 5335A Device Commands | 3-27 |
| 3-190. | Function Selection FU, FN | 3-31 |
| 3-192. | Gate Time Setting GA, GO, GC | 3-31 |
| 3-194. | Remote Display DR0, DR1, DI | 3-31 |
| 3-196. | Default States | 3-31 |
| 3-199. | Initialize | 3-31 |
| 3-201. | Learn Mode Programming P?, PQ, PB | 3-31 |
| 3-205. | SRQ and Status SR | 3-32 |
| 3-209. | Program Execution/Response Times | 3-32 |
| 3-211. | Output Format | 3-32 |
| 3-217. | Output Modes | 3-34 |
| 3-223. | Output of Statistics | 3-34 |
| 3-226. | Programming Anomalies | 3-34 |
| 3-228. | Programming Examples | 3-35 |
| 3-230. | Trigger Level Programming Example | 3-45 |
| 3-232. | Options | 3-46 |
| 3-234. | Time Base Option 010 | 3-46 |

TABLE OF CONTENTS (Continued)

| Section | Title | Page |
|---------|---|------|
| III | OPERATION AND PROGRAMMING (Continued) | |
| | 3-236. Digital Voltmeter Option 020 | 3-46 |
| | 3-238. C Channel Option 030 | 3-46 |
| | 3-240. Programmable Input Option 040 | 3-46 |
| | 3-242. Operator's Maintenance | 3-46 |
| | 3-245. Power/Warm-Up | 3-47 |
| | 3-248. Operator's Check | 3-47 |
| | 3-252. Error/Fail Messages | 3-47 |
| | 3-254. Operator Instruction Label | 3-47 |
| IV | PERFORMANCE TESTING | 4-1 |
| | 4-1. Introduction | 4-1 |
| | 4-3. Equipment Required | 4-1 |
| | 4-5. Test Record | 4-1 |
| | 4-7. Error/Fail Messages | 4-1 |
| | 4-9. Local Operational Verification | 4-1 |
| | 4-13. Preliminary Procedures | 4-2 |
| | 4-15. Power-Up/Self Check Test Procedure I | 4-2 |
| | 4-18. Super Check Test Procedure II | 4-2 |
| | 4-22. Front End (Input Amplifier) Switch Test Procedure III | 4-3 |
| | 4-24. Rear Panel External Arm Slope Switch Test Procedure IV | 4-4 |
| | 4-26. Keyboard Check Test Procedure V | 4-5 |
| | 4-28. DVM Test (Option 020) Procedure VI | 4-6 |
| | 4-30. Channel "C" Test (Option 030) Procedure VII | 4-6 |
| | 4-32. Programmable Input Amplifier Test (Option 040) Procedure VIII | 4-6 |
| | 4-34. Performance Test for the 5335A and All Options | 4-7 |
| | 4-37. Power-Up/Self Check Test Procedure I | 4-7 |
| | 4-40. Supercheck Test Procedure II | 4-7 |
| | 4-43. Keyboard Check Test Procedure III | 4-8 |
| | 4-46. Rear Panel — External Arm Switch Test Procedure IV | 4-8 |
| | 4-49. Gate Time Test Procedure V | 4-9 |
| | 4-53. Channel A and B Frequency Response and Sensitivity Test Procedure VI | 4-10 |
| | 4-62. Ratio A/B Function Test Procedure VII | 4-11 |
| | 4-66. Time Interval and Inverse Time Interval Test Procedure VIII .. | 4-14 |
| | 4-70. Pulse Width A and Pulse Width B Procedure IX | 4-15 |
| | 4-74. Rise and All Time A Test Procedure X | 4-16 |
| | 4-78. Slew Rate A Test Procedure XI | 4-17 |
| | 4-82. Phase A rel B Test Procedure XII | 4-17 |
| | 4-86. DVM (Option 020) Test Procedure XIII | 4-18 |
| | 4-90. Channel C (Option 030) Test Procedure XIV | 4-18 |
| | 4-94. HP-IB Verification Program Using the 9825A Controller | 4-20 |
| | 4-103. 5335A HP-IB Verification Program Using the 85A Controller ... | 4-40 |
| V | ADJUSTMENTS | 5-1 |
| | 5-1. Introduction | 5-1 |
| | 5-4. Equipment Required | 5-1 |
| | 5-6. Adjustment Locations | 5-1 |
| | 5-8. Safety Considerations | 5-1 |

TABLE OF CONTENTS (Continued)

| Section | Title | Page |
|---------|---|------|
| V | ADJUSTMENTS (Continued) | |
| 5-10. | Adjustment Procedures | 5-1 |
| 5-11. | A1 Power Supply Adjustment Procedure | 5-1 |
| 5-13. | A3 Input Amplifier Adjustment Procedure | 5-2 |
| 5-15. | A8 Digital Voltmeter (Option 020) Adjustment Procedure | 5-4 |
| 5-17. | A9 Channel C Adjustment Procedure | 5-4 |
| 5-19. | Oscillator Adjustment Procedure (Local and Option 010) | 5-5 |
| 5-21. | A2 Channel A and B Level Shifter Adjustment Procedure | 5-6 |
| 5-23. | Channel A and B Peak Detector Adjustment Procedure | 5-7 |
| 5-25. | A6 Rear Panel Assembly Adjustment Procedure | 5-7 |
| 5-27. | Option 040 Adjustment Procedures | 5-9 |
| 5-29. | A12 Programmable Input Amplifier (Option 040) Adjustment Procedure | 5-9 |
| 5-31. | A12 Peak Detectors Adjustment Procedure | 5-11 |
| 5-33. | A12C46 Adjustment Procedure | 5-11 |
| 5-34. | A12C30 Adjustment Procedure | 5-12 |
| 5-35. | A11 DAC Adjustment Procedure | 5-13 |
| VI | REPLACEABLE PARTS | 6-1 |
| 6-1. | Introduction | 6-1 |
| 6-3. | Abbreviations | 6-1 |
| 6-5. | Replaceable Parts | 6-1 |
| 6-9. | Ordering Information | 6-1 |
| 6-12. | Direct Mail Order System | 6-1 |
| VII | MANUAL CHANGES | 7-1 |
| 7-1. | Introduction | 7-1 |
| 7-3. | Manual Changes | 7-1 |
| 7-6. | Older Instruments | 7-1 |
| 7-8. | Selected Components (A3 Series 2120 or Below) | 7-8 |
| 7-10. | Procedure for Selecting R7, R8, R80, or R81 in A3 Assembly ... | 7-8 |
| VIII | SERVICE | 8-1 |
| 8-1. | Introduction | 8-1 |
| 8-3. | Schematic Diagram Symbols and Reference Designators | 8-1 |
| 8-5. | Reference Designations | 8-1 |
| 8-7. | Identification Markings on Printed-Circuit Boards | 8-1 |
| 8-11. | Assembly Identification | 8-3 |
| 8-13. | Safety Considerations | 8-4 |
| 8-18. | Safety Symbols | 8-5 |
| 8-20. | Recommended Test Equipment | 8-5 |
| 8-22. | Service Aids | 8-5 |
| 8-23. | Pozidriv Screwdrivers | 8-5 |
| 8-25. | Service Aids on Printed Circuit Boards | 8-5 |
| 8-27. | How to Use the A16 Service Aid Board (05335-60013) | 8-5 |
| 8-31. | Factory Selected Components | 8-6 |
| 8-33. | Procedure to Select A3R83 on the Amplifier Buffer Assembly | 8-6 |

TABLE OF CONTENTS (Continued)

| Section | Title | Page |
|---------|--|------|
| VIII | SERVICE (Continued) | |
| 8-34. | Procedure to Select A3R29 on the Amplifier Buffer Assembly | 8-6 |
| 8-35. | Procedure to Select the X10 Compensating Capacitors A3C37 and A3C23 | 8-6 |
| 8-36. | Logic Symbols | 8-7 |
| 8-38. | Explanation of New Logic Symbols | 8-7 |
| 8-39. | Introduction | 8-7 |
| 8-44. | Symbol Composition | 8-8 |
| 8-51. | Qualifying Symbols | 8-9 |
| 8-64. | Dependency Notation | 8-13 |
| 8-124. | Bistable Elements | 8-20 |
| 8-128. | Coders | 8-21 |
| 8-136. | Use of Binary Grouping to Produce Affecting Inputs | 8-22 |
| 8-138. | Sequence of Input Labels | 8-23 |
| 8-143. | Sequence of Output Labels | 8-23 |
| 8-150. | Theory of Operation | 8-24 |
| 8-151. | Overall Counter Operation | 8-24 |
| 8-156. | Functional Descriptions of Assemblies | 8-26 |
| 8-158. | A1 Power Supply Assembly | 8-26 |
| 8-161. | A13 Line Module | 8-26 |
| 8-163. | A2 Amplifier Support Board | 8-26 |
| 8-166. | Auto-Triggering and Peak-Detectors | 8-26 |
| 8-175. | Reading Trigger Levels | 8-28 |
| 8-178. | Address Bus and Data Bus Signals | 8-28 |
| 8-180. | A3 Input Amplifier Buffer | 8-28 |
| 8-186. | A4 Main Logic Board | 8-29 |
| 8-194. | Interpolator Technique | 8-29 |
| 8-205. | A5 Keyboard and Display | 8-32 |
| 8-208. | A6 Rear Panel Board | 8-32 |
| 8-214. | A7 Hewlett-Packard Interface Bus Board | 8-32 |
| 8-218. | A14 HP-IB Connector Board | 8-32 |
| 8-220. | A8 Digital Voltmeter Board | 8-32 |
| 8-223. | A9 Channel C Input Amplifier Board (Option 030) | 8-33 |
| 8-226. | A10 Switch Panel (Option 040) | 8-33 |
| 8-229. | A11 Amplifier Support Board (Option 040) | 8-33 |
| 8-234. | A12 Programmable Input Amplifier (Option 040) | 8-34 |
| 8-239. | A15 Temperature-Controlled 10 MHz Time Base Oscillator (Option 010) | 8-34 |
| 8-241. | Troubleshooting (Failure Analysis) | 8-34 |
| 8-245. | Built-In Diagnostics | 8-35 |
| 8-246. | Introduction | 8-35 |
| 8-247. | Accessing the Built-In Diagnostics | 8-35 |
| 8-252. | Shaded Block Diagrams | 8-36 |
| 8-254. | Diagnostic #1: "Super Check" | 8-36 |
| 8-267. | Diagnostic #2: Signature Analysis Stimulus Mode | 8-39 |
| 8-270. | Diagnostic #3 and #4: Front End Latch Control Test | 8-39 |
| 8-274. | Diagnostic #5: Front End Switch Test | 8-39 |
| 8-278. | Diagnostic #6: Rear Panel Arm-Slope Switch Test | 8-39 |
| 8-281. | Diagnostic #7: HP-IB Switch Status | 8-44 |
| 8-284. | Diagnostic #9: MRC Short Test | 8-44 |

TABLE OF CONTENTS (Continued)

| Section | Title | Page |
|---------|---|------|
| VIII | SERVICE (Continued) | |
| 8-286. | Diagnostic #10: MRC Extended Test | 8-47 |
| 8-288. | Diagnostics #11, #12, and #13: Interpolator Counters Tests | 8-47 |
| 8-293. | Diagnostic #14: Front End Check | 8-47 |
| 8-295. | Diagnostic #15: Front Panel Display Test | 8-47 |
| 8-297. | Diagnostic #16: HP-IB Address Switch | 8-51 |
| 8-299. | Diagnostic #17: Keyboard Check | 8-51 |
| 8-301. | Diagnostic #18 and #19: DAC Adjustment (Option 040) | 8-51 |
| 8-305. | Diagnostic #20, #21, and #22: DVM Reference Test (Option 020) | 8-53 |
| 8-308. | Diagnostic #23, #24, and #25: DVM Range Test (Option 020) | 8-53 |
| 8-310. | Diagnostic #26, #27, and #28: Trigger Level Reference Test | 8-53 |
| 8-312. | Diagnostic #29 and #30: Trigger Levels A and B Test | 8-53 |
| 8-314. | Diagnostic #31, #32, #33: A4 DVM Power Supplies Test | 8-53 |
| 8-316. | Diagnostic #34: Incremental Testing of the DAC's (Option 040) | 8-53 |
| 8-318. | Overall Troubleshooting | 8-56 |
| 8-322. | Power-Up Self-Check | 8-56 |
| 9-331. | Super Check (Diagnostic #01) | 8-58 |
| 8-336. | Procedure for Inaccessible Diagnostics | 8-58 |
| 8-338. | Power Supply Test | 8-59 |
| 8-345. | A2 Troubleshooting | 8-60 |
| 8-347. | Trigger Level Selector Troubleshooting | 8-60 |
| 8-351. | Front End Latch Control Troubleshooting | 8-61 |
| 8-366. | Trigger Level Voltmeter Troubleshooting | 8-63 |
| 8-373. | Signal Selector Multiplexer Troubleshooting | 8-64 |
| 8-376. | Prescaler Troubleshooting | 8-65 |
| 8-378. | A3 Input Amplifier Buffer Troubleshooting | 8-65 |
| 8-380. | Input Offset Buffer Troubleshooting | 8-65 |
| 8-384. | Peak Detectors Troubleshooting | 8-67 |
| 8-388. | A3 Troubleshooting Accessories | 8-67 |
| 8-390. | A3 Troubleshooting Out-of-Cabinet Setup | 8-68 |
| 8-391. | Peak Detectors in Manual Mode Troubleshooting | 8-68 |
| 8-396. | Peak Detectors in Auto Mode Troubleshooting | 8-68 |
| 8-398. | Schmitt Amplifier Troubleshooting | 8-69 |
| 8-400. | Bridge Limiter Troubleshooting | 8-69 |
| 8-404. | A4 Main Logic Troubleshooting | 8-69 |
| 8-406. | Microprocessor System Troubleshooting | 8-69 |
| 8-410. | Troubleshooting the A4 Assembly Using "STIMULUS MODE" and Signature Analysis | 8-72 |
| 8-413. | Signature Analysis of the 5335A in the STIMULUS MODE | 8-72 |
| 8-415. | START and STOP Interpolators Troubleshooting | 8-73 |
| 8-423. | Time Base Troubleshooting | 8-76 |
| 8-425. | 4 MHz Microprocess Oscillator Troubleshooting | 8-76 |
| 8-426. | 10 MHz Time Base Oscillator Troubleshooting | 8-77 |
| 8-427. | Power-Up Rest Troubleshooting | 8-77 |
| 8-429. | A5 and A10 Keyboard and Display Assemblies Troubleshooting | 8-77 |

TABLE OF CONTENTS (Continued)

| Section | Title | Page |
|---------|--|------|
| VIII | SERVICE (Continued) | |
| | 8-436. A6 Rear Panel Assembly Troubleshooting | 8-79 |
| | 8-438. GATE OUT Circuitry Troubleshooting | 8-79 |
| | 8-440. External Arm Input Circuitry Troubleshooting | 8-80 |
| | 8-442. Time Base Multiplier Troubleshooting | 8-80 |
| | 8-445. EXTERNAL ARM Switches Troubleshooting | 8-81 |
| | 8-447. A7 HP-IB Assembly Troubleshooting | 8-81 |
| | 8-450. A8 Digital Voltmeter Troubleshooting | 8-82 |
| | 8-456. Input Amplifier and Range Control Troubleshooting | 8-84 |
| | 8-459. Reference and Voltage Multiplexer Troubleshooting | 8-84 |
| | 8-461. Voltage-to-Frequency Converter Troubleshooting | 8-84 |
| | 8-463. Input Logic Switch Control Troubleshooting | 8-85 |
| | 8-466. Power Supply Troubleshooting | 8-85 |
| | 8-468. A9 Channel C (Option 030) Troubleshooting | 8-85 |
| | 8-474. A11 Amplifier Support Troubleshooting | 8-87 |
| | 8-476. Trigger Level Selector Troubleshooting | 8-87 |
| | 8-479. Front End Latch Control Troubleshooting | 8-87 |
| | 8-484. Troubleshooting the A11U5 Multiplexer | 8-87 |
| | 8-488. Troubleshooting the Relay Drivers | 8-88 |
| | 8-490. Digital-to-Analog Converter Troubleshooting | 8-88 |
| | 8-496. Troubleshooting the Data Latch Enablers U19 and U20 | 8-88 |
| | 8-500. Trigger Level Voltmeter Troubleshooting | 8-89 |
| | 8-507. Signal Selector Multiplexer Troubleshooting | 8-90 |
| | 8-510. Prescaler Troubleshooting | 8-90 |
| | 8-512. A12 Input Amplifier Troubleshooting | 8-92 |
| | 8-514. Input Offset Buffer Troubleshooting | 8-92 |
| | 8-518. Peak Detectors Troubleshooting | 8-93 |
| | 8-522. A12 Troubleshooting Accessories | 8-94 |
| | 8-524. A12 Troubleshooting Out-of-Cabinet Setup | 8-94 |
| | 8-525. Troubleshooting Peak Detectors in Manual Mode | 8-94 |
| | 8-530. Troubleshooting Peak Detectors in Auto Manual | 8-94 |
| | 8-532. Schmitt Amplifier Troubleshooting | 8-95 |
| | 8-534. Bridge Limiter Troubleshooting | 8-95 |
| | 8-538. Diagrams and Photos | 8-95 |

LIST OF TABLES

| Table | Title | Page |
|-------|--|------|
| 1-1. | Model 5335A Specifications | 1-2 |
| 1-2. | Equipment Supplied | 1-5 |
| 1-3. | Accessories Available | 1-5 |
| 1-4. | Recommended Test Equipment | 1-6 |
| 2-1. | Field Installable Options | 2-4 |
| 3-1. | Function Key Use During Number Entry | 3-9 |
| 3-2. | Function Key Reference Summary | 3-21 |
| 3-3. | HP-IB Interface Capability | 3-22 |
| 3-4. | 5335A Bus Message Usage | 3-24 |
| 3-5. | HP-IB Address Switch Selections | 3-25 |
| 3-6. | 5335A Device Commands | 3-28 |
| 3-7. | Status Bits Usage with SRQ | 3-32 |
| 3-8. | HP-IB Response Times | 3-33 |
| 4-1. | Error Messages | 4-1 |
| 4-2. | Fail Messages | 4-1 |
| 4-3. | 9825A Verification Program Printout | 4-21 |
| 4-4. | HP-IB Verification Program Listing (9825A Controller) | 4-34 |
| 4-5. | 5335A HP-IB Verification Program Listing (HP 85A Controller) | 4-41 |
| 5-1. | Adjustments | 5-1 |
| 5-2. | Frequency Offset Estimation | 5-6 |
| 5-3. | Option 050 Adjustments | 5-9 |
| 6-1. | Abbreviations and Reference Designations | 6-2 |
| 6-2. | Replaceable Parts | 6-3 |
| 6-3. | Miscellaneous Replaceable Parts | 6-17 |
| 6-4. | Option 020 DVM Replaceable Parts | 6-28 |
| 6-5. | Option 030 "C" Channel Replaceable Parts | 6-30 |
| 6-6. | Option 040 Programmable Input Replaceable Parts | 6-32 |
| 6-7. | Manufacturers Code List | 6-40 |
| 7-1. | Manual Backdating | 7-1 |
| 7-2. | A6 (05335-60006) Series 1928 Replaceable Parts | 7-5 |
| 7-3. | A3 Series 2120 or below Selected Components | 7-9 |
| 7-4. | Selecting A3R7, R8, R80 or R81 | 7-9 |
| 8-1. | Assemblies and Major Parts Usage | 8-3 |
| 8-2. | General Qualifying Symbols | 8-9 |
| 8-3. | Qualifying Symbols for Inputs and Outputs | 8-11 |
| 8-4. | Symbols Inside the Outline | 8-12 |
| 8-5. | Summary of Dependency Notation | 8-13 |
| 8-6. | Diagnostics | 8-35 |
| 8-7. | A1 Power Supply Voltage Tests | 8-59 |
| 8-8. | A2U2 Analog Multiplexer Control Bits | 8-60 |
| 8-9. | Troubleshooting A2U12 and A2U15 | 8-61 |
| 8-10. | Troubleshooting A2U16 Signatures | 8-62 |
| 8-11. | A1U4 Analog Multiplexer Control Bits | 8-63 |

LIST OF TABLES (Continued)

| Table | Title | Page |
|--------------|--|-------------|
| 8-12. | U4 Input Voltage with Output Frequency at U8(1) | 8-64 |
| 8-13. | A2U7 Outputs Related to Control Bits C6, C9, and C10 | 8-65 |
| 8-14. | Peak Detector Control Signals | 8-67 |
| 8-15. | A4U28 Signatuares, Logic States, and Voltages | 8-70 |
| 8-16. | A4 Signatures | 8-70 |
| 8-17. | A4U23 Signatures | 8-71 |
| 8-18. | A4U22 Signatures | 8-72 |
| 8-19. | A5 Keyboard and Display Connector Pins | 8-78 |
| 8-20. | A6 Rear Panel Board Connector Pins | 8-79 |
| 8-21. | External Arm Data Lines States | 8-81 |
| 8-22. | HP-IB Assembly Pin Connections (A4/A7) | 8-81 |
| 8-23. | HP-IB Assembly Pin Connections (A7/A14) | 8-82 |
| 8-24. | HP-IB Interface Connector Signal | 8-82 |
| 8-25. | A8 Connector Pin Functions | 8-83 |
| 8-26. | A8Q4, Q5, and Q6 States in Diagnostics #23 #24 and #25 | 8-84 |
| 8-27. | A8TP1 Voltages for Diagnostics #23 #24 and #25 | 8-84 |
| 8-28. | A8U7 States in Diagnostics #20-#25 | 8-84 |
| 8-29. | A8 Voltage-to-Frequency Conversion | 8-84 |
| 8-30. | A8 Input Logic Switching Troubleshooting | 8-85 |
| 8-31. | A11U2 Analog Multiplexer Control Bits | 8-87 |
| 8-32. | Troubleshooting A11U14 and A11U15 | 8-87 |
| 8-33. | A11U5 Control Signals | 8-88 |
| 8-34. | A11 Relay Driver Collector Voltages | 8-88 |
| 8-35. | A11 Data Latch Logic Levels | 8-88 |
| 8-36. | A2U4 Analog Multiplexer Control Bits | 8-90 |
| 8-37. | Input Voltage vs Output Frequency | 8-90 |
| 8-38. | A11U7 Outputs Related to Control Bits C9 and C10 | 8-91 |
| 8-39. | Peak Detector Control Signals | 8-93 |

LIST OF FIGURES

| Figure | Title | Page |
|---------------|--|-------------|
| 1-1. | Model 5335A Universal Counter with Option 040, Option 030, Option 020, Option 010, and Accessories Supplied | 1-0 |
| 2-1. | Line Voltage Selection | 2-1 |
| 2-2. | Power Cable HP Part Numbers versus Mains Plugs Available | 2-2 |
| 2-3. | Hewlett-Packard Interface Bus Connections | 2-3 |
| 2-4. | Details of Input Connector J1 and Fuse Mounting | 2-6 |
| 3-1. | Function Group Keys | 3-4 |
| 3-2. | GATE and CYCLE Controls | 3-5 |
| 3-3. | INPUT Group Controls | 3-6 |
| 3-4. | Option 040 INPUT Group Controls | 3-6 |
| 3-5. | Auto-Triggering Range | 3-7 |
| 3-6. | Auto Triggering with PRESET Selected | 3-8 |
| 3-7. | Trigger Indicator Light Response | 3-8 |
| 3-8. | MATH and FUNCTION Keys | 3-8 |
| 3-9. | STATISTICS Group Keys | 3-10 |

LIST OF FIGURES (Continued)

| Figure | Title | Page |
|--------|--|------|
| 3-10. | INPUT C Control Panel | 3-11 |
| 3-11. | VOLTS Panel | 3-11 |
| 3-12. | Front Panel Features | 3-11 |
| 3-13. | Rear Panel Features | 3-12 |
| 3-14. | ARMING MODES Timing Diagram | 3-12 |
| 3-15. | External Arming Signal Enable | 3-13 |
| 3-16. | Pulsed CW Signal Measurement | 3-13 |
| 3-17. | Varying Frequency Pulsed CW (Chirp) Signal Measurement | 3-14 |
| 3-18. | Pulse Distortion from AC Coupling | 3-14 |
| 3-19. | Advantage of DC Coupling for Pulse Signals | 3-14 |
| 3-20. | Time Interval Measurement Relationships | 3-15 |
| 3-21. | Rise Time Measurement | 3-15 |
| 3-22. | Delayed Time Interval Measurement | 3-15 |
| 3-23. | Time Interval Between Selected Pulses | 3-16 |
| 3-24. | Counting Groups of Pulses | 3-16 |
| 3-25. | Specific Time Interval/Pulse Counting | 3-16 |
| 3-26. | Frequency Ratio Measurement Connections | 3-17 |
| 3-27. | Velocity Measurement | 3-17 |
| 3-28. | Pulse Width Measurement | 3-18 |
| 3-29. | Waveform Rise and Fall Time Measurement | 3-18 |
| 3-30. | Duty Cycle Measurements | 3-19 |
| 3-31. | Voltage Measurement Time | 3-20 |
| 3-32. | Waveform Phase Relationship | 3-20 |
| 3-33. | Details of Input Connector J1 and Fuse Mounting | 3-46 |
| 3-34. | 5335A Operating Instructions Label | 3-48 |
| | | |
| 4-1. | Front End Input Switch Test Display | 4-4 |
| 4-2. | Rear Arm Switch Test Display | 4-5 |
| 4-3. | Keyboard Check Key Assignments | 4-5 |
| 4-4. | Option 040 DAC Test Setup | 4-6 |
| 4-5. | Keyboard Check Key Assignments | 4-8 |
| 4-6. | Rear Arm Switch Test Display | 4-9 |
| 4-7. | Channel A Frequency Response and Sensitivity Test Setup (20 MHz) | 4-10 |
| 4-8. | Channel A Frequency Response and Sensitivity Test Setup (200 MHz) | 4-11 |
| 4-9. | Channel B Frequency Response and Sensitivity Test Setup (20 MHz) | 4-12 |
| 4-10. | Channel B Frequency Response and Sensitivity Test Setup | 4-12 |
| 4-11. | Ratio A/B Test Setup (10 Hz to 20 MHz) | 4-13 |
| 4-12. | Ratio A/B Test Setup (20 MHz to 200 MHz) | 4-14 |
| 4-13. | Time Interval and Inverse Time Interval Test Setup | 4-14 |
| 4-14. | Pulse Width A and Pulse Width B Test Setup | 4-15 |
| 4-15. | Rise and Fall Time A Test Setup | 4-16 |
| 4-16. | Rise and Fall Time A Test Waveform | 4-16 |
| 4-17. | Phase A rel B Test Setup | 4-17 |
| 4-18. | DVM Test Setup (Option 020) | 4-18 |
| 4-19. | Channel C Test Setup (Option 030) | 4-19 |
| 4-20. | HP-IB Verification Setup (9825A Controller) | 4-20 |
| 4-21. | 5335A HP-IB Verification Setup (HP 85A Controller) | 4-40 |

LIST OF FIGURES (Continued)

| Figure | Title | Page |
|---------------|---|-------------|
| 5-1. | Input Amplifier Adjustment Setup | 5-2 |
| 5-2. | Input Amplifier Adjust Waveform | 5-3 |
| 5-3. | Channel C Sensitivity Adjustment Setup | 5-5 |
| 5-4. | Oscillator Adjustment Setup | 5-5 |
| 5-5. | Level Shifter Adjustment Setup | 5-6 |
| 5-6. | Rear Panel Assembly Adjustment Setup | 5-8 |
| 5-7. | Programmable Input Amplifier Adjustment Setup | 5-10 |
| 5-8. | Input Amplifier Adjustment Waveform | 5-11 |
| 5-9. | A12C46 Adjustment Setup | 5-12 |
| 5-10. | A12C30 Adjustment Test Setup | 5-12 |
| 5-11. | Peak Detector Adjustment Setup | 5-13 |
| | | |
| 6-1. | Cabinet Parts | 6-19 |
| 6-2. | Top View Parts | 6-20 |
| 6-3. | View A Parts | 6-21 |
| 6-4. | View B Parts | 6-22 |
| 6-5. | View C Parts | 6-23 |
| 6-6. | View D Parts | 6-24 |
| 6-7. | Side View Parts | 6-25 |
| 6-8. | Rear Panel Parts | 6-26 |
| 6-9. | Bottom View Parts | 6-27 |
| | | |
| 7-1. | A6 (05335-60006) Series 1928 Component Locator | 7-6 |
| 7-2. | A6 (05335-60006) Series 1928 Schematic Diagram | 7-7 |
| 7-3. | A13 Part Number 0960-0448 Schematic Diagram | 7-8 |
| | | |
| 8-1. | Schematic Diagram Notes | 8-2 |
| 8-2. | Test Setup for A3C37 and C23 Selection | 8-7 |
| 8-3. | Symbol Composition | 8-8 |
| 8-4. | Illustration of Common-Control Block | 8-8 |
| 8-5. | Illustration of Common-Output Element | 8-9 |
| 8-6. | G Dependency Between Inputs | 8-14 |
| 8-7. | G Dependency Between Outputs and Inputs | 8-14 |
| 8-8. | G Dependency with A Dynamic Input | 8-14 |
| 8-9. | OR'ed Affecting inputs | 8-15 |
| 8-10. | Substitution for Numbers | 8-15 |
| 8-11. | V (OR) Dependency | 8-15 |
| 8-12. | N (Negate, X-OR) Dependency | 8-15 |
| 8-13. | Z (Interconnection) Dependency | 8-16 |
| 8-14. | X (Transmission) Dependency | 8-17 |
| 8-15. | C (Control) Dependency | 8-17 |
| 8-16. | S (Set) and R (Reset) Dependencies | 8-17 |
| 8-17. | EN (Enable) Dependency | 8-18 |
| 8-18. | M (Mode) Dependency | 8-18 |
| 8-19. | Type of Flip-Flop Determined by Mode | 8-19 |
| 8-20. | Disabling an Output of the Common Control Block | 8-19 |
| 8-21. | Determining an Output Function | 8-19 |
| 8-22. | Dependent Relationship Affected by Mode | 8-19 |

LIST OF FIGURES (Continued)

| Figure | Title | Page |
|--------|--|------|
| 8-23. | A (Address) Dependency | 8-20 |
| 8-24. | RAM Example | 8-20 |
| 8-25. | Four Types of Bistable Circuits | 8-21 |
| 8-26. | Coder General Symbol | 8-21 |
| 8-27. | An X-Y Code Converter | 8-21 |
| 8-28. | An X-Octal Code Converter | 8-22 |
| 8-29. | Coder Producing Several Dependencies | 8-22 |
| 8-30. | Coder Producing One Type of Dependency | 8-22 |
| 8-31. | Use of Binary Grouping Symbol | 8-22 |
| 8-32. | Input Labels | 8-23 |
| 8-33. | Factoring Input Labels | 8-23 |
| 8-34. | Placement of Three-State Symbols | 8-23 |
| 8-35. | Output Labels | 8-24 |
| 8-36. | Factoring Output Labels | 8-24 |
| 8-37. | Simplified Block Diagram | 8-25 |
| 8-38. | Trigger Modes Relationships | 8-26 |
| 8-39. | Peak Detector Simplified Schematic | 8-27 |
| 8-40. | Interpolator Timing Diagram | 8-30 |
| 8-41. | Expanded Interpolator Error Pulse | 8-30 |
| 8-42. | Short and Long Calibration Pulses Example | 8-31 |
| 8-43. | Diagnostic #01 Shaded Block Diagram | 8-38 |
| 8-44. | Diagnostic #02 Shaded Block Diagram | 8-40 |
| 8-45. | Diagnostic #05 Shaded Block Diagram | 8-41 |
| 8-46. | Diagnostic #05 Display | 8-42 |
| 8-47. | Diagnostic #06 Display | 8-42 |
| 8-48. | Diagnostic #06 Shaded Block Diagram | 8-43 |
| 8-49. | Diagnostic #07 Display | 8-44 |
| 8-50. | Diagnostics #07 and -16 Shaded Block Diagram | 8-45 |
| 8-51. | Diagnostics #09 and #10 Shaded Block Diagram | 8-46 |
| 8-52. | Diagnostics #11, #12, and #13 Shaded Block Diagram | 8-48 |
| 8-53. | Diagnostic #14 Shaded Block Diagram | 8-49 |
| 8-54. | Diagnostics #15 and #17 Shaded Block Diagram | 8-50 |
| 8-55. | Diagnostics #16 Display Example | 8-51 |
| 8-56. | Diagnostic #17 Keyboard Check Key Assignments | 8-51 |
| 8-57. | Diagnostics #18 and #19 Shaded Block Diagram | 8-52 |
| 8-58. | Diagnostics #20 through #25 Shaded Block Diagram | 8-54 |
| 8-59. | Diagnostics #26 through #33 Shaded Block Diagram | 8-55 |
| 8-60. | Troubleshooting Flowchart | 8-57 |
| 8-61. | Power Supply Block Diagram (A1) | 8-60 |
| 8-62. | Relay Driver A2Q1 Voltage | 8-61 |
| 8-63. | Diagnostic #5 Display Response | 8-62 |
| 8-64. | A2U14 Signatures | 8-62 |
| 8-65. | Trigger Level DVM Block Diagram | 8-63 |
| 8-66. | Signal Select Block Diagram | 8-64 |
| 8-67. | Prescaler A2U11 Reset (C6) Voltages | 8-65 |
| 8-68. | Channel A Input Buffer DC Voltages | 8-66 |
| 8-69. | Peak Detector Block Diagram A2-A3-A4 | 8-67 |
| 8-70. | Peak Detector Test Signal | 8-68 |
| 8-71. | A3U6 and A3U1 Pin Voltages | 8-68 |
| 8-72. | A4 Block Diagram | 8-69 |

LIST OF FIGURES (Continued)

| Figure | Title | Page |
|--------|---|-------|
| 8-73. | Simplified Interpolators Schematic | 8-73 |
| 8-74. | Diagnostic 11 Waveform, A4U31 and A4U5 | 8-74 |
| 8-75. | Diagnostic 11 Waveform, A4U4 and A4U5 | 8-75 |
| 8-76. | Diagnostic 12 Waveform, A4U31, A4U5, and A4U4 | 8-75 |
| 8-77. | Diagnostic 12 Waveform, A4U5 and A4U4 | 8-75 |
| 8-78. | Diagnostic 13 Waveform, A4U31 and A4U5 | 8-76 |
| 8-79. | Diagnostic 13 Waveform, A4U4 and A4U5 | 8-76 |
| 8-80. | 4 MHz Microprocessor Oscillator Signal | 8-76 |
| 8-81. | 1 MHz Microprocessor Oscillator Signal | 8-77 |
| 8-82. | 10 MHz Timebase Oscillator Signal | 8-77 |
| 8-83. | Power-Up Reset Circuit Waveform | 8-77 |
| 8-84. | A5 Keyboard and Display Block Diagram | 8-78 |
| 8-85. | A6 Rear Panel Block Diagram | 8-79 |
| 8-86. | Waveform at A6Q4 Base | 8-79 |
| 8-87. | Waveform at A6Q5 Base | 8-79 |
| 8-88. | Waveform at A6Q5 Collector (Into 1 Ω) | 8-80 |
| 8-89. | Waveform at A6Q5 Collector (Into 50 Ω) | 8-80 |
| 8-90. | A6 External Arm Test Waveforms | 8-80 |
| 8-91. | A6 Timebase Multiplier Test Waveforms | 8-80 |
| 8-92. | A7 HP-IB Block Diagram | 8-81 |
| 8-93. | A8 Digital Voltmeter (Option 020) Block Diagram | 8-83 |
| 8-94. | A9 Channel C (Option 030) Block Diagram | 8-86 |
| 8-95. | A9 Waveforms at TP1 and TP3 | 8-86 |
| 8-96. | A11U19 and A11U20 Signatures | 8-89 |
| 8-97. | Trigger Level DVM Block Diagram | 8-89 |
| 8-98. | Signal Select Block Diagram | 8-91 |
| 8-99. | Channel A Input Buffer DC Voltages | 8-92 |
| 8-100. | Block Diagram of Peak Detectors in A11 and A12 | 8-93 |
| 8-101. | Peak Detectors Test Signal | 8-94 |
| 8-102. | A12U6 and A12U1 Pin Voltages | 8-95 |
| 8-103. | 5335A Block Diagram with Options 010, 020, and 030 | 8-97 |
| 8-104. | 5335A Block Diagram with Option 040 | 8-99 |
| 8-105. | Assembly and Cable Locator with Options 010, 020, and 030 | 8-101 |
| 8-106. | Assembly and Cable Locator with Option 040 | 8-103 |
| 8-107. | A1 Power Supply Assembly and A13 Line Module | 8-105 |
| 8-108. | A2 Amplifier Supply Assembly | 8-107 |
| 8-109. | A3 Amplifier Buffer Assembly | 8-109 |
| 8-110. | A4 Main Logic Assembly | 8-111 |
| 8-111. | A5 Keyboard and Display Assembly | 8-113 |
| 8-112. | A6 Rear Panel Assembly | 8-115 |
| 8-113. | A7 HP-IB Logic Assembly and A14 HP-IB Connector Assembly | 8-117 |
| 8-114. | A8 Digital Voltmeter (Option 020) Assembly | 8-119 |
| 8-115. | A9 Channel C (Option 030) Assembly | 8-121 |
| 8-116. | A10 Switch Panel (Option 040) Assembly | 8-123 |
| 8-117. | A11 Amplifier Support (Option 040) Assembly | 8-127 |
| 8-118. | A12 Programmable Input Amplifier (Option 040) Assembly | 8-129 |
| 8-119. | A15 10 MHz Oscillator (Option 010) Assembly | 8-131 |
| 8-120. | A16 Service Aid Board | 8-132 |
| 8-121. | A17 Shield Board (Option 040) | 8-133 |

PREFACE

This manual is designed to present the information required by the user to effectively operate and maintain the 5335A Universal Counter.

It is divided into sections, each relating to a specific topic. As much as possible the sections are self-contained. It is the intention of this manual to allow for the quick location of desired information, while still providing the overall depth of detail required. Some sections provide the learning and working information, and will be used frequently. Other sections are dedicated to general and introductory types of information, and are intended to be used only for reference. Where applicable, photos, illustrations, and diagrams foldout allowing the user access to related information throughout the manual.

In limiting the depth of coverage in this manual, a certain amount of previous knowledge on the part of the reader must be assumed. A variety of additional related documentation is available. These materials address in depth the specific areas of interest, and should be used, whenever necessary, to supplement this manual. Users unfamiliar with HP-IB or Logic Symbology, for example, may want to refer to the 5335A Documentation Map to find additional sources of information.

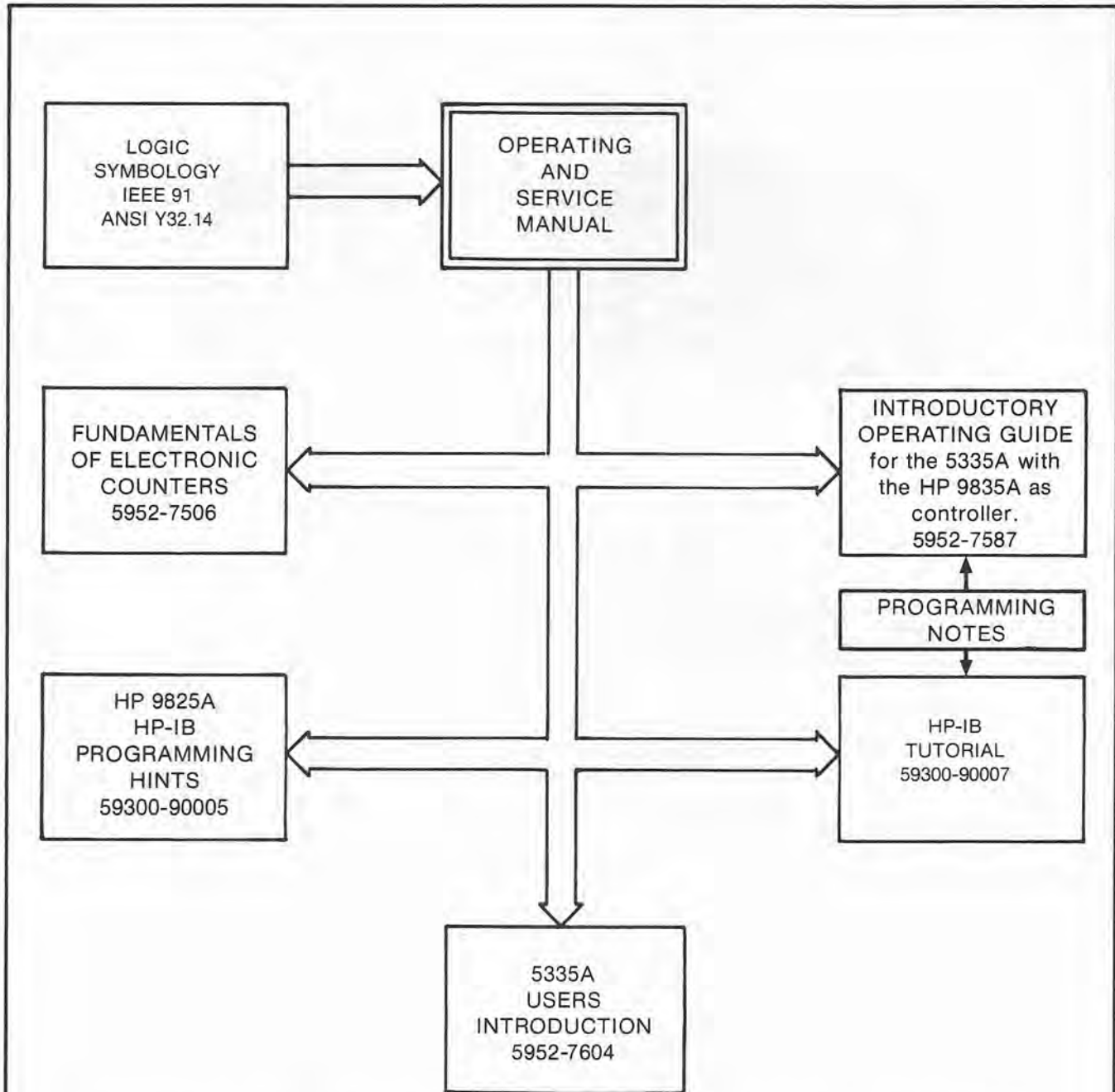

5335A/9835A INTRODUCTORY OPERATING GUIDE — Provides basic HP-IB interconnection information, remote programming examples and applications; specifically for the HP 5335A Universal Counter, using the HP 9835A as controller.

5335A OPERATING AND SERVICE MANUAL — Provides primary operating instructions and service information.

5335A USER'S GUIDE — Provides expanded operating instruction and instrument specific applications.

FUNDAMENTALS OF ELECTRONIC COUNTERS (AN 200) — Provides the basic concepts, techniques, and underlying principles of electronic counters.

HP 8725A HP-IB PROGRAMMING HINTS — Includes a variety of HP-IB related documents, including general bus theory and instrument specific programming examples.

5335A PROGRAM NOTES — Supplemental HP-IB programming information, provided in simple step-by-step format. Written for a specific instrument and specific controller.

IEEE 91 (ANSI Y32.14) — Describes logic symbols used in this manual.

HP-IB Tutorial — Describes fundamentals of Hewlett-Packard Interface Bus.

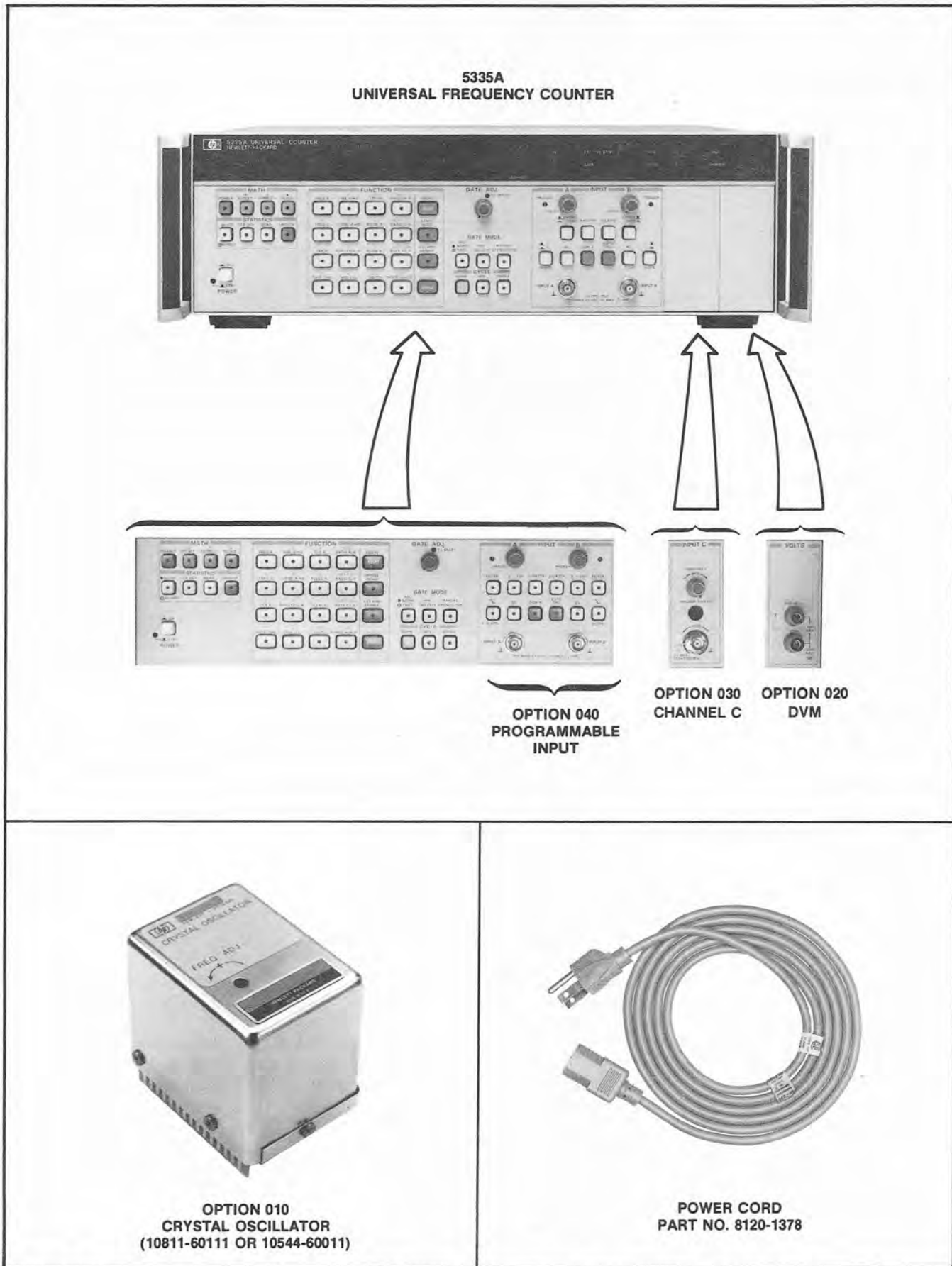

Figure 1-1. Model 5335A Universal Counter with Option 040, Option 030, Option 020, Option 010, and Accessories Supplied

SECTION I GENERAL INFORMATION

1-1. INTRODUCTION

1-2. This Operating and Service Manual contains the information required to install, operate, test, adjust, and service the Hewlett-Packard Model 5335A Universal Frequency Counter. *Figure 1-1* shows two examples of the 5335A counter. One instrument is a standard unit with no options. The other instrument has the optional digital voltmeter (Option 20), the third input amplifier or "C" channel (Option 30), and the programmable input amplifiers (Option 40).

1-3. MANUAL SUMMARY

1-4. This manual is divided into eight sections, each covering a particular topic for the operation and service of the HP 5335A. The topics by section number are:

SECTION I, GENERAL INFORMATION. Provides the instrument specifications, instrument identification, description of options, accessories and recommended test equipment.

SECTION II, INSTALLATION. Provides information about initial inspection, preparation for use, storage and shipment, field installation of options, and HP-IB interconnections.

SECTION III, OPERATION AND PROGRAMMING. Provides information about operating characteristics, panel features, local and remote operating instructions, operator's maintenance, and programming. The operation of Options 020, 030 and 040 is included in this section.

SECTION IV, OPERATIONAL VERIFICATION. Provides abbreviated procedures for operational verification which give the operator a high degree of confidence that the 5335A is operating properly.

SECTION V, ADJUSTMENTS. Provides the procedures required to properly maintain the instrument operating characteristics within specifications.

SECTION VI, REPLACEABLE PARTS. Provides ordering information for all replaceable parts and assemblies within the instrument.

SECTION VII, MANUAL CHANGES. This section contains manual change information which effectively "backdates" the technical areas of the manual to apply to older instruments.

SECTION VIII, SERVICE. This section provides the instrument theory of operation, troubleshooting information, repair techniques, and schematic diagrams.

1-5. SPECIFICATIONS

1-6. The instrument specifications are listed in *Table 1-1*. These specifications are the performance standards or limits against which the instrument may be tested.

1-7. SAFETY CONSIDERATIONS

1-8. The 5335A Universal Counter is a Safety Class I instrument (provided with a protective earth terminal), designed according to international safety standards. This operating and service manual contains information, cautions, and warnings which must be followed by the user to ensure safe operation and keep the instrument in safe condition.

1-9. INSTRUMENT IDENTIFICATION

1-10. Hewlett-Packard instruments have a two-section, ten-character serial number (0000A00000), which is located on the rear panel. The four-digit serial prefix identifies instrument changes. If the serial prefix of your instrument differs from that listed on the title page of this manual, there are differences between this manual and your instrument. Instruments having higher serial prefixes are covered with a "Manual Changes" sheet included with this manual. If the change sheet is missing, contact the nearest Hewlett-Packard Sales and Service Office listed at the back of this manual. Instruments having a lower serial prefix than that listed on the title page are described in Section VII.

1-11. ACCESSORIES

1-12. *Table 1-2* lists accessory equipment supplied and *Table 1-3* lists accessories available.

Table 1-1. Model 5335A Specifications

| INPUT CHARACTERISTICS (Channel A and B) | PERIOD A | DUTY CYCLE** A |
|--|---|--|
| <p>Range: DC coupled, 0 to 100 MHz. AC 1 MΩ, 30 Hz to 100 MHz. AC 50 Ω, 200 KHz to 100 MHz. NOTE: Channel A range 200 MHz when in Frequency A and Ratio modes.</p> <p>Sensitivity (X1): 25 mV rms sine wave. 75 mV peak-to-peak pulse at minimum pulse width of 5 ns.</p> <p>Dynamic Range (X1): 75 mV to 5V peak-to-peak, to 100 MHz. 75 mV to 2.5V peak-to-peak, > 100 MHz.</p> <p>Signal Operating Range (X1, DC): -5V dc to +5V dc.</p> <p>Crosstalk (X1): <500 mV rms, 0 to 100 MHz, or <250 mV rms, 100 to 200 MHz, sine wave in either channel will not affect other channel.</p> <p>Trigger Level Range (X1): Auto Trigger OFF: Preset: Set to 0V dc NOMINAL. Adjustable: -5V dc to +5V dc. Auto Trigger ON: Preset: Set to NOMINAL 50% point of input signal. Adjustable: NOMINALLY between + and - peaks of input signal.</p> <p>Auto Trigger (X1): Range (50% duty cycle): DC coupled, 30 Hz to 200 MHz. AC 1 MΩ, 30 Hz to 200 MHz. AC 50 Ω, 200 kHz to 200 MHz. Minimum Signal: 100 mV rms. Duty Cycle Range: 10% to 90%. Response Time: 3 seconds TYPICAL. NOTE: Auto Trigger requires a repetitive signal.</p> <p>Coupling: AC or DC, switchable. Impedance: 1 MΩ NOMINAL shunted by <35 pF, or 50 Ω NOMINAL, switchable. In COMMON A, 1 MΩ is shunted by <50 pF. Attenuator: X1 or X10 NOMINAL, switchable. Slope: Independent selection of + or - slope. Channel Input: SEPARATE or COMMON A, switchable.</p> <p>Damage Level (AC or DC): 1 MΩ X 1: DC to 2 kHz 250V (DC + AC rms) 2 to 100 kHz (5 X 10³V rms Hz) /FREQ >100 kHz 5V rms 1 MΩ X 10: DC to 20 kHz 250V (DC + AC rms) 20 to 100 kHz (5 X 10³V rms Hz) /FREQ >100 kHz 50V rms 50Ω: DC to 200 MHz 5V rms</p> | <p>Range: 10 ns to 10⁷s. LSD** Displayed: $\frac{1 \text{ ns}}{\text{Gate Time}} \times \text{PER.}$ (e.g., 9 digits in a second) Resolution: $\pm (2 \times \text{LSD}) \pm 1.4 \times \frac{\text{Trigger Error}^{**}}{\text{Gate Time}} \times \text{PER.}$ Accuracy: $\pm (\text{Resolution}) \pm (\text{Time Base Error}) \times \text{PER.}$ Period Average: User selects MEAN function, and n = 100, or n = 1,000.</p> | <p>Range: 1% to 99%, 0 to 100 MHz. Trigger Point Range: 40% to 60% of pulse height. LSD** Displayed: $\frac{1 \text{ ns}}{\text{PER}} \times 100\%$ Resolution: $\pm \left(\frac{\text{PULSE} + \text{PULSE Accuracy} }{\text{PER} - \text{PER Resolution} } - \text{DUTY CY} \right) \times 100\%$ Accuracy: $\pm \left(\frac{\text{PULSE} + \text{PULSE Accuracy} }{\text{PER} \times \text{PER Accuracy} } - \text{DUTY CY} \right) \times 100\%$ Gate Mode: MIN only. NOTE: Constant duty cycle required during measurement.</p> |
| | <p>TIME INTERVAL A-B</p> | |
| | <p>Range: 0 ns to 10⁷s. LSD** Displayed: 1 ns (100 ps using MEAN). Resolution: $\pm (2\text{XLS}) \pm (\text{START Trigger Error}^{**}) \pm (\text{STOP Trigger Error}^{**})$. Accuracy: $\pm (\text{Resolution}) \pm (\text{Time Base Error}) \times \text{TI} \pm (\text{Trigger Level Timing Error}^{**}) \pm (2 \text{ ns})$. Gate Mode: MIN only. Time Interval Average: User selects MEAN function, n = 100 or n = 1,000.</p> | |
| | <p>TIME INTERVAL DELAY (Holdoff)</p> <p>For Time A-B, 1/Time A-B, Pulse A, (Time B-A, Pulse B), front panel Gate Adjust control inserts a variable delay between START and enabling of STOP. Electrical inputs during delay are ignored. Delay ranges are same as gate time ranges (100 μs to 4s NOMINAL) for gate modes of Fast, Norm, and Manual. Delay measured by pressing Gate Time key. All other specifications are same as Time Interval A-B.</p> | |
| | <p>INVERSE TIME INTERVAL A - B</p> | |
| | <p>Range: 10⁻⁷ to 10⁹ units/second. LSD Displayed, Resolution, and Accuracy are inverse of Time Interval A - B specifications. If Time Interval A - B is zero, display will be zero.</p> | |
| | <p>RISE AND FALL TIME A</p> | |
| | <p>Range: 20 ns to 10 ms Minimum Pulse Height: 500 mV peak-to-peak. Minimum Width at Peak of Signal: 20 ns. Duty Cycle Range: 20% to 80%. LSD Displayed and Resolution are same as Time Interval A-B specifications. Accuracy: $\pm (\text{TI Accuracy}) \pm (\text{Trigger Level Setting Error}^{**} \text{ at } 10\% \text{ point}) \pm (\text{Trigger Level Setting Error}^{**} \text{ at } 90\% \text{ point})$. Input Mode: Automatically set to COMMON A with 10% and 90% trigger levels. Gate Mode: MIN only.</p> | |
| | <p>PULSE WIDTH A</p> | |
| | <p>Range: 5 ns to 10⁷s. Trigger Point Range: 40% to 60% of pulse height. LSD Displayed and Resolution are same as Time Interval A - B specifications. Accuracy: $\pm (\text{Resolution}) \pm (\text{Time Base Error}) \times \text{PULSE} \pm (\text{Trigger Level Timing Error}^{**}) \pm 2\text{ns}$.</p> | |
| | | <p>SLEW RATE** A</p> |
| | | <p>Range: 50 V/s to 10⁶ V/s slew rate Minimum Pulse Height, Width, and Duty Cycle Range are same as Rise and Fall Time A. LSD** Displayed: $\frac{1 \text{ ns}}{ \text{RISE/FALL} } \times \text{SLEW}$; three digits maximum. Resolution: $\pm \left(\frac{ \text{TRIG LVL B} - \text{TRIG LVL A} + 20 \text{ mV}}{ \text{RISE/FALL} - \text{RISE/FALL Resolution} - \text{SLEW} } \right)$. Accuracy: $\pm \left(\frac{ \text{TRIG LVL B} - \text{TRIG LVL A} \times 1.003 + 40 \text{ mV}}{ \text{RISE/FALL} - \text{RISE/FALL Accuracy} - \text{SLEW} } \right)$.</p> |
| | | <p>Input Mode: Automatically set to COMMON A with 10% and 90% trigger levels. Gate Mode: MIN only.</p> |
| | | <p>RATIO A/B</p> |
| | | <p>Range: Channel A, 0 to 200 MHz (prescaled by 2). Channel B, 0 to 100 MHz. LSD** Displayed: RATIO FREQ × Gate Time where FREQ is higher frequency after prescaling. Resolution: $\pm \text{LSD} \pm \frac{\text{Trigger Error}}{\text{Gate Time}} \times \text{RATIO}$, where Trigger Error is on lower frequency after prescaling. Accuracy: Same as Resolution.</p> |
| | | <p>TOTALIZE A</p> |
| | | <p>Range: 0 to 100 MHz. LSD** Displayed: 1 count of input HP-IB Output: At end of gate. Manual: Count Reset: Via RESET key. HP-IB Output: Totalize data on-the-fly sent if Cycle mode set to Single. Input frequency range in this mode is 0 to 50 Hz NOMINAL. Gated: Count Reset: Automatic after measurement. Resolution: $\pm \text{LSD}$ Accuracy: Same as Resolution.</p> |
| <p>FREQUENCY A</p> <p>Range: 0 to 200 MHz, prescaled by 2. LSD** Displayed: $\frac{1 \text{ ns}}{\text{Gate Time}} \times \text{FREQ.}$ (e.g., 9 digits in a second) Resolution: $\pm (2 \times \text{LSD}) \pm 1.4 \times \frac{\text{Trigger Error}^{**}}{\text{Gate Time}} \times \text{FREQ.}$ Accuracy: $\pm (\text{Resolution}) \pm (\text{Time Base Error}) \times \text{FREQ.}$</p> | | |

**See Definitions section for further information.

Table 1-1. Model 5335A Specifications (Continued)

PHASE A rel B**

Range: -180° to 360°, Range Hold off, or 0° to 360°, Range Hold on, with signal repetition rates of 30 Hz to 1 MHz.
Minimum Signal: 100 mV rms.
LSD Displayed:** 0.1°.

Input Mode: Automatically set to 50% trigger level in A and B channels.
Gate Mode: MIN only.
NOTE: Constant phase required during measurement.

Resolution:

$$\left[\pm \frac{T_{I1} + |T_{I1} \text{ Resolution}| + T_{I2} + |T_{I2} \text{ Resolution}|}{2 | \text{PER A} - | \text{PER A Resolution} | } \right] \times 360^\circ - \text{PHASE (expressed in } + \text{ degrees)}$$

Accuracy:

$$\left[\pm \text{Resolution} + \frac{T_{I1} \pm T_{I1} \text{ error} + T_{I2} \pm T_{I2} \text{ error}}{2 (\text{PER A} + \text{PER error})} \right] \times 360^\circ - \text{PHASE (expressed in } + \text{ degrees)}$$

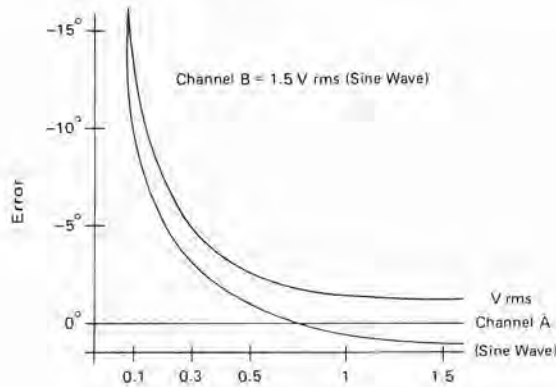

Typical phase uncertainty for PHASE A rel B measurements where channel B is 1.5 V RMS and channel A is varied in amplitude

NOTE: When signal B is smaller than signal A phase measurement uncertainty tends to be positive. T_{I1} and T_{I2} are times between 50% points of A and B as illustrated in the DEFINITIONS section.

T_{I1} error and T_{I2} error are the errors due to: 1) Trigger Level Timing Error, 2) Trigger Level Setting Error, and 3) Trigger Error due to noise.

GATE TIME

Range: 100 ns to 10⁷s.
LSD Displayed:** Up to three digits with Ext. Arm Enable OFF, 100 ns when ON. MIN Gate Mode display zero.
NOTE: Time displayed and actual gate time may differ due to input signal synchronization of gate.

TRIGGER LEVEL

Range: X1, +5 to -5 volts.
X10, +50 to -50 volts.
Resolution: X1, 10 mV; X10, 100 mV.
Accuracy (X1): ±20 mV, ±0.5% of reading.
NOTE: Reading is center point of hysteresis band. When in X10, reading is multiplied by 10.

TIME BASE

Standard Crystal:
Frequency: 10 MHz.
Aging Rate: <3 × 10⁻⁷/month.
Temperature: <4 × 10⁻⁶, 0 to 50°C.
Line Voltage: <1 × 10⁻⁷ for 10% change.
High Stability Crystal: See Option 010.
External Time Base Input: Rear panel BNC accepts 5 or 10 MHz, 200 mV rms into 1 kΩ; 5V rms maximum.
Time Base Out: 10 MHz, >1V p-p into 50 Ω via rear panel.

STATISTICS

Sample Size: Selectable between either N=100 or N=1000 samples.
Std. Dev.: Displays a standard deviation of selected sample size.
Mean: Displays mean estimate of selected sample size.
Smooth: Performs a weighted running average and truncates unstable least significant digits from display.
NOTE: Statistics functions performed after Math functions.

MATH

All measurement functions with exception of GATE TIME, TOTALIZE in scale mode, and TRIG LVL, may be operated upon by Math functions. Offset, Normalize, and Scale may be used independently or together as follows:

$$\text{Display} = \frac{\text{Measurement} + \text{Offset}}{\text{Normalize}} \times \text{Scale.}$$

Numbers are entered via blue labeled keys. DISABLE key will toggle off and on all active math keys.
Number Value Range: ±1 × 10⁻⁹ to ±9 × 10⁹.
Last Display: Causes value of previous display to Offset (negative value), Normalize, or Scale all subsequent measurements.
Measurement t-1: Causes each new measurement to be Offset (negative value), Normalized, or Scaled by each immediately preceding measurement.

**HEWLETT-PACKARD
INTERFACE BUS**

Programmable Controls: All measurement functions, Math, Statistics, Reset, Range Hold, Ext. Arm Enable/Slope, Check, Gate Adj. (~1 ms to 1s), Gate Open/Close (gate time to ∞), Gate Mode, Cycle, Preset, Slope, Common A, Auto trigger.
Special Functions: FREQ B, PULSE B, TIME B→A, TOT A-B, LEARN, MIN, MAX, all internal diagnostic routines.
HP-IB Commands: Trigger, Clear, Remote, Local, Local Lockout, Require Service.
Data Output Rate: Fixed output format consisting of 19 characters plus CR and LF output in TYPICALLY 8 ms. Number of readings/second dependent on function, gate, and cycle used (~15 readings/second maximum).

GENERAL

Function Memory: Front panel settings for Math, Statistics, Range Hold, Ext. Arm Enable, Gate, and Cycle stored for current function and immediately preceding function. GATE TIME and TRIG LVL do not affect memory.
Gate: Minimum, manual, or continuously variable (NORM/FAST) via Gate Adj. control.
NORM: 20 ms to 4s NOMINAL.
FAST: 100 μs to 20 ms NOMINAL.
MIN: Minimum gate time. Actual time depends on function. For FREQ A, (FREQ B), FREQ C, and PER A, minimum gate = (one period of input) × (prescale factor).
MANUAL: Each press opens or closes gate.
Cycle: Determines delay between measurements.
NORM: No more than 4 readings per second NOMINAL.
MIN: Updates display as rapidly as possible (~15 readings per second, depending on function).
SINGLE: One measurement taken with each press of button.
Arming: Ext. Arm Enable key allows rear panel input to determine Start and/or Stop point of a measurement. External gate defined by both Start and Stop armed. All measurements are armable except Manual Totalize, Phase, and Trigger Level.
Start Arm: + or - slope of arm input signal starts measurement.
Stop Arm: + or - slope of arm input signal stops measurement. When used, Start arm must occur before Stop arm.
Ext. Arm Input: Rear panel BNC accepts TTL into 20 kΩ.
Minimum Start to Stop Time: 200 ns.
Trigger Level Out: DC output into 1 MΩ via rear panel BNC's for Channel A and B; not adjusted for attenuators.
Accuracy at DC (X1): ±15 mV ± 0.5% of TRIG LVL reading.
Gate Out: TTL level into 1 KΩ goes low when gate open; rear panel BNC.
Range Hold: Freezes decimal point and exponent of display.
Reset: Starts a new measurement cycle when pressed.
Check: Performs internal self test and lamp test.
Display: 12 digit LED display in engineering format; exponent range of +18 to -18.
Overflow: All measurements which would theoretically cause a display of more than 12 digits will display 12 most significant digits.
Operating Temperature: 0 to 50°C.
Power Requirements: 100, 120, 220, 240 VAC (+5%, -10%), 48-66 Hz; 130 VA max.
Weight: Net, 8.8 kg (19 lbs. 8 oz.); shipping, 13.6 kg (30 lbs.).
Dimensions: 425.5 mm W × 132.6 mm H × 345.4 mm D (16 1/4" × 5 1/4" × 13 1/2"), not including removable handles.

**See Definitions section for further information.

Table 1-1. Model 5335A Specifications (Continued)

OPTIONS

Option 010: High Stability Time Base (Oven)
Frequency: 10 MHz.
Aging Rate: $< 5 \times 10^{-10}$ /day after 24 hr. warm up.
Short Term: $< 1 \times 10^{-10}$ rms for 1s average.
Temperature: $\approx 7 \times 10^{-9}$, 0 to 50°C.
Line Voltage: $< 1 \times 10^{-10}$ for 10% change.
Warm-Up: Within 5×10^{-9} of final value in 20 min.

Option 020: DC Digital Voltmeter
Range: 4 digits, autoranging, autopolarity, in ± 10 , ± 100 , ± 1000 V ranges.
Sensitivity: 100 μ V, 1 mV, 10 mV, 100 mV for ± 1 V, ± 10 V, ± 100 V, ± 1000 V readings.
LSD Displayed:** Same as sensitivity.
Accuracy (10 min. warm-up): $\pm 0.045\%$ of reading $\pm 0.02\%$ of range; for 1000V range, $\pm 0.06\%$ of reading $\pm 0.02\%$ of range. For 60 days at 24°C $\pm 5^\circ$ C, RH $< 80\%$, and gate > 100 ms.
Temperature Coefficient: $\pm (0.0055\%$ of reading $+ 0.005\%$ of range)/°C; for 1000V range, $\pm (0.008\%$ of reading $+ 0.0005\%$ of range)/°C.
Input Type: Floating pair.
Input Impedance: 10 M Ω $\pm 1\%$.
Maximum Input: Hi to Lo, ± 1000 V all ranges. Low to chassis ground, ± 500 V.
Response Time: 100 ms to within 1% of final value, within one range.
Normal Mode Rejection: 30 dB at 50/60 Hz.
Effective Common Mode Rejection (1 k Ω unbalanced): ≥ 110 dB at 50/60 Hz.
Filter: Single pole from 10 Hz NOMINAL.

Option 030: 1.3 GHz C Channel
Input Characteristics
Range: 150 MHz to 1.3 GHz, prescaled by 20.
Sensitivity:
 10 mV rms sine wave (-27 dBm) to 1 GHz.
 100 mV rms sine wave (-7 dBm) to 1.3 GHz.
 Sensitivity can be decreased continuously by up to 20 dB NOMINAL, 150 to 1000 MHz and 14 dB NOMINAL, 1 to 1.3 GHz via sensitivity control. Trigger level is fixed at OV NOMINAL.

Dynamic Range:
 10 mV to 1 V rms (40 dB), to 1 GHz.
 100 mV to 1 V rms (20 dB), to 1.3 GHz.

Signal Operating Range: +5V dc to -5V dc.

Coupling: AC.

Impedance: 50 Ω NOMINAL (VSWR, $< 2.5:1$ TYPICAL).

Damage Level: ± 3 V (DC + AC peak), fuse protected. Fuse located in BNC connector.

Frequency C

Range: 150 MHz to 1.3 GHz, prescaled by 20.

LSD Displayed, Resolution, and Accuracy** are same as Frequency A.

Ratio C/A

Range:
 Channel A, 0 to 200 MHz (prescaled by 2.)
 Channel C, 150 to 1300 MHz (prescaled by 20).
LSD Displayed, Resolution, and Accuracy** are same as Ratio A/B.

Option 040: Expanded HP-IB Control
Added Programmable Controls: Trigger level, input coupling, filter, input impedance, attenuation.

Trigger Level:
Range: ± 5 Vdc in 10 mV steps.
Accuracy: ± 30 mV of programmed level in X1; ± 300 mV in X10 NOMINAL
Setup Time: < 50 ms from HP-IB command.

NOTE: Level programmed is center of hysteresis band. When in X10, displayed level is 10 times entered value. Rear panel trigger level is not multiplied by 10 in X10 mode.

Input Coupling: AC or DC
Low Pass Filter: 150 kHz (Nom.), -30 dB down at 200 MHz (Nom.)
Input Impedance: 1M Ω NOMINAL shunted by < 45 pf, or 50 Ω NOMINAL. In Common A, 1 M Ω is shunted by < 55 pf.
Attenuator: X1 or X10 NOMINAL
Auto-Trigger: 50 mV ms sensitivity in PRESET, 30 Hz to 200 MHz (100 MHz in Channel B).

DEFINITIONS

LSD Displayed: Unit value of Least Significant Digit displayed. Calculations should be rounded up to nearest decade, with a 12 digit mantissa maximum. If truncation required, most significant digits are kept.

Trigger Error:

$$\frac{\sqrt{e_1^2 + e_n^2}}{\text{Input slew rate at trigger point}} \text{ sec rms}$$

where $e_1 = 260 \mu$ V, typical, and is the effective rms noise of the 5335A input channel; e_n is the rms noise voltage of the signal input for a 200 MHz bandwidth.

Trigger Level and Trigger Point (X1):

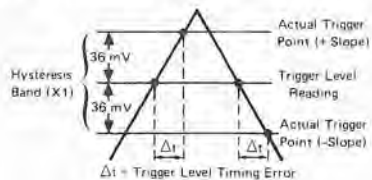

Trigger Level Timing Error (X1): Applies to Time Interval measurements;

$$\frac{36 \text{ mV}}{|\text{Input slew rate at START trigger point}| \text{ minus } 36 \text{ mV} |\text{Input slew rate at STOP trigger point}|}$$

Trigger Level Setting Error (X1): Applies to Rise/Fall, Slew, and Phase measurements:

$$\frac{\pm 2\% \text{ of input p-p voltage} \pm 40 \text{ mV}}{\text{Input slew rate at trigger point}}$$

Duty Cycle: Percentage of time a signal is high or low, depending on Slope A setting. Trigger point is high/low dividing point.

$$\text{DUTY CY} = \frac{\text{PULSE}}{\text{PER}} \times 100\%;$$

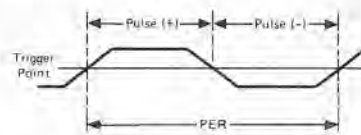

Slew Rate: Effective slope between 10% and 90% points of rising or falling signal depending on Slope A setting.

$$\text{SLEW} = \frac{V_B - V_A}{T_I}$$

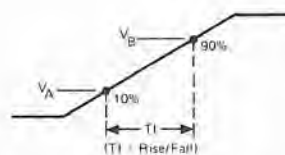

Phase: Angle, with respect to B signal, between 50% points of Channel A and B signals, trigger slopes selected by Channel A and B slope switches.

$$\text{PHASE} = \frac{T_{I1} + T_{I2}}{2 \text{ PER}} \times 360^\circ;$$

T_{I1} is time between 50% points of A then B signals using slopes defined during Phase measurement.

T_{I2} is time between 50% points of A then B signals using complement slopes to T_{I1} .

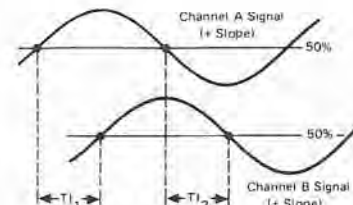

*Specifications describe the instrument's warranted performance. Supplemental characteristics are intended to provide information useful in applying the instrument by giving TYPICAL or NOMINAL, but nonwarranted performance parameters. Definition of terms is provided at the end of the specification section. For a more detailed explanation, see Application Note 200-4 "Understanding Frequency Counter Specifications".

Table 1-2. Equipment Supplied

| DESCRIPTION | HP PART NUMBER |
|--|----------------|
| Detachable Power Cord 229 cm (7 1/2 feet long) | 8120-1378 |

Table 1-3. Accessories Available

| DESCRIPTION | HP PART NUMBER |
|---|-----------------|
| Option 910 Additional Manual | |
| Rack Mounting Adapter Kits: | |
| Rack Mount with Handles attached; Option 913 | 5060-0171 |
| Rack Mount with Handles removed Option 908 | 5061-0077 |
| Signature Analyzer | Model 5004A |
| 2-1300 MHz Preamplifier | Model HP 10855A |
| Time Interval Probes | Model 5363B |

1-13. DESCRIPTION

1-14. The HP Model 5335A is a Universal Counter capable of measuring signals in the 200 MHz range. The instrument's basic measurement functions include Frequency, Period, Time, Ratio, and Totalize. The resident microprocessor and multiple-register-counter expand the usefulness of the counter by allowing post-measurement data manipulation. This allows the additional power and convenience of user-defined measurement function keys for Statistical Data, Math Functions, Pulse Width, Rise/Fall Time, Slew Rate, Duty Cycle, and Phase Relationship. Interpolating oscillators, phaselocked to the instrument's time base, allow measurements to be resolved near a nanosecond.

1-15. The 5335A input provides two independent channels, featuring matched high performance 200 MHz input amplifiers. Each input channel includes a full complement of input signal conditioning controls. Additionally, the 5335A offers extensive control of triggering and arming. Most measurements are displayed in scientific notation, with the digits grouped into three's for convenience. Four modes of gate selection are provided on the front panel.

1-16. HP-IB provides remote control of programming and data output.

1-17. OPTIONS

1-18. The following lists the options available for the 5335A. Specifications for the options are given in *Table 1-1*. If an option is included in the initial order, it will be installed at the factory and ready for operation upon receipt. For field installation of Options 010, 020, 030 and 040, refer to Section II for part numbers and instructions.

| Option | Description |
|--------|--|
| 010 | High Stability Time Base (Oven Oscillator) |
| 020 | DC Voltmeter Module |
| 030 | C Channel Input Module A/B |
| 040 | Programmable Input Amplifiers |

1-19. RECOMMENDED TEST EQUIPMENT

1-20. The test equipment listed in *Table 1-4* is recommended for use during performance tests, adjustments, and troubleshooting. Substitute test equipment may be used if it meets the required characteristics listed in the table.

Table 1-4. Recommended Test Equipment

| INSTRUMENT | REQUIRED SPECIFICATION | QUANT. | RECOMMENDED HP MODEL | USE |
|--|-----------------------------------|--------|----------------------|----------|
| Oscilloscope | 200 MHz bandwidth, X-Y capability | 1 | 1715A | T, A |
| Digital Voltmeter | 20V range, 0.05V resolution | 1 | 3456A/B | A, T |
| Signature Analyzer | 5335A compatibility | 1 | 5004A | T |
| Controller | HP-IB compatible | 1 | 9825A | OV |
| | • HP-IB interface for 9825A | 1 | 98034A | OV |
| | • String-Adv. Programming ROM | 1 | 98210A | OV |
| | • Plotter-Gen I/O — Extended I/O | 1 | 98214A | OV |
| | HP-IB compatible | 1 | HP-85 | OV |
| | • Input/Output ROM | 1 | 00085-15003 | OV |
| | • ROM Drawer | 1 | 82936A | OV |
| Function Generator | | | 82937A | OV |
| | | | 3312A | A, P, OV |
| Signal Generator | 200 MHz bandwidth | 1 | 8654A/B | OV, P |
| 50Ω RF Termination | SMC type | 2 | 1250-0839 | T |
| Synthesized Signal Generator | 1300 MHz, 150 mV rms | 1 | 8660B/86603A | A, OV, P |
| Front Panel switch replacement tool (heat stacking tool) | | 1 | 5020-8160 | T |
| Flat Ribbon assembly | 26-AWG, 18-conductors | 2 | 8120-2463 | T |
| | 50-ohm cable assembly | 2 | 05335-60112 | T |
| | SMC male-to-male adapter | 2 | 1250-0827 | T |

- * = See Additional Listing in User's Guide Manual!
- T = Troubleshooting
- A = Adjustments
- P = Performance Tests
- OV = Operation Verification

SECTION II INSTALLATION

2-1. INTRODUCTION

2-2. This section contains information for unpacking, inspection, storage, and installation.

2-3. UNPACKING AND INSPECTION

2-4. If the shipping carton is damaged, inspect the instrument for visible damage (scratches, dents, etc.). If the instrument is damaged, notify the carrier and the nearest Hewlett-Packard Sales and Service Office immediately (offices are listed at the back of this manual.) Keep the shipping carton and packing material for the carrier's inspection. The Hewlett-Packard Sales and Service Office will arrange for repair or replacement of your instrument without waiting for the claim against the carrier to be settled.

2-5. PREPARATION FOR USE

2-6. Power Requirements

2-7. The 5335A requires a power source as listed in *Table 1-1*.

2-8. Line Voltage Selection

2-9. The HP 5335A Universal Frequency Counter is equipped with a power module that contains a printed circuit line voltage selector card to select 100-, 120-, 220-, or 240-volt ac operation. Before applying power, the pc selector card must be set to the correct position and the correct fuse must be installed as described below.

CAUTION

Before connecting the instrument to ac power lines, be sure that the voltage selector is properly positioned as described below.

2-10. Power line connections are selected by the position of the plug-in pc selector card in the module. When the card is plugged into the module, the only visible markings on the card indicate the line voltage to be used. The correct value of line fuse, must be installed after the card is inserted. This instrument uses a power line fuse as listed in Section VI.

2-11. To convert from one line voltage to another, the power cord must be disconnected from the power module before the sliding window covering the fuse and card compartment can be moved to expose the fuse and circuit card. See *Figure 2-1*.

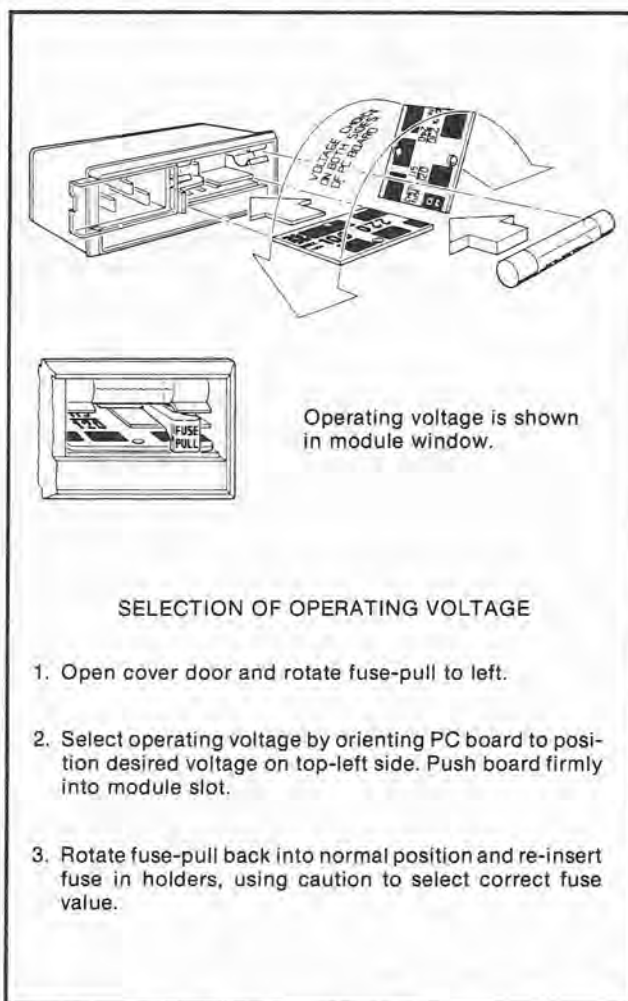

Figure 2-1. Line Voltage Selection

2-12. Pull on the fuse lever to remove the fuse and then pull the card out of the module. The fuse lever must be held to one side to extract and insert the card. Insert the card so the marking that agrees with the line voltage to be used is visible.

2-13. Return fuse lever to normal position, insert correct fuse, slide plastic window over the compartment, and connect the power cord to complete the conversion.

2-14. Power Cable

WARNING

BEFORE SWITCHING ON THIS INSTRUMENT, THE PROTECTIVE EARTH TERMINALS OF THIS INSTRUMENT MUST BE CONNECTED TO THE PROTECTIVE CONDUCTOR OF THE (MAINS) POWER CORD. THE MAINS PLUG SHALL ONLY BE INSERTED IN A SOCKET OUTLET PROVIDED WITH A PROTECTIVE EARTH CONTACT. THE PROTECTIVE ACTION MUST NOT BE NEGATED BY THE USE OF AN EXTENSION CORD (POWER CABLE) WITHOUT A PROTECTIVE CONDUCTOR (GROUNDING).

2-15. The 5335A is shipped with a three-wire power cable. When the cable is connected to an appropriate ac power source, this cable connects the chassis to earth ground. The type of power cable plug shipped with each instrument depends on the country of destination. Refer to *Figure 2-2* for the part numbers of the power cable and plug configurations available.

2-16. Operating Environment

2-17. All environmental specifications are listed in *Table 1-1*.

2-18. **HUMIDITY.** The 5335A may be operated in environments with humidity as listed in *Table 1-1*. However, it should be protected from temperature extremes which cause condensation in the instrument. Option 020, DVM, may be operated in environments with humidity up to 80%.

2-19. HP-IB INTERCONNECTIONS

2-20. **HEWLETT-PACKARD INTERFACE BUS.** Interconnection data concerning the rear panel HP-IB connector is provided in *Figure 2-3*. This connector is compatible with the HP 10631A/B/C/D HP-IB cables. The HP-IB system allows interconnection of up to 15 (including the controller) HP-IB compatible instruments. The HP-IB cables have identical "piggyback" connectors on both ends so that several cables can be connected to a single source without special adapters or switch boxes. System components and devices may be connected in virtually any configuration desired. There must, of course, be a path from the controller to every device operating on the bus. As a practical

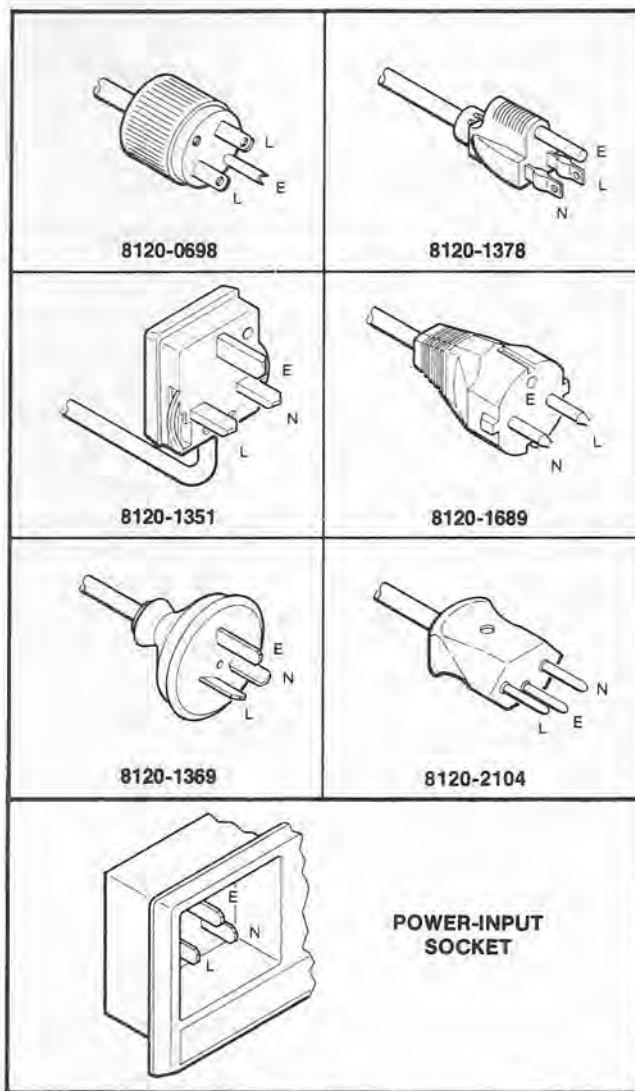

Figure 2-2. Power Cable HP Part Numbers versus Mains Plugs Available

matter, avoid stacking more than three cables on any one connector. If the stack gets too large, the force on the stack produces great leverage which can damage the connector mounting. Be sure each connector is firmly (finger tight) screwed in place to keep it from working loose during use.

2-21. **CABLE LENGTH RESTRICTIONS.** To achieve design performance with the HP-IB, proper voltage levels and timing relationship must be maintained. If the system cable is too long, the lines cannot be driven properly and the system will fail to perform properly. therefore, when interconnecting an HP-IB system, it is important to observe the rules in *Figure 2-3*.

| PIN | LINE |
|-----|------------------------------|
| 1 | DIO1 |
| 2 | DIO2 |
| 3 | DIO3 |
| 4 | DIO4 |
| 13 | DIO5 |
| 14 | DIO6 |
| 15 | DIO7 |
| 16 | DIO8 |
| 5 | EOI |
| 17 | REN |
| 6 | DAV |
| 7 | NRFD |
| 8 | NDAC |
| 9 | IFC |
| 10 | SRQ |
| 11 | ATN |
| 12 | SHIELD-CHASSIS GROUND |
| 18 | P/O TWISTED PAIR WITH PIN 6 |
| 19 | P/O TWISTED PAIR WITH PIN 7 |
| 20 | P/O TWISTED PAIR WITH PIN 8 |
| 21 | P/O TWISTED PAIR WITH PIN 9 |
| 22 | P/O TWISTED PAIR WITH PIN 10 |
| 23 | P/O TWISTED PAIR WITH PIN 11 |
| 24 | ISOLATED DIGITAL GROUND |

THESE PINS ARE INTERNALLY GROUNDED

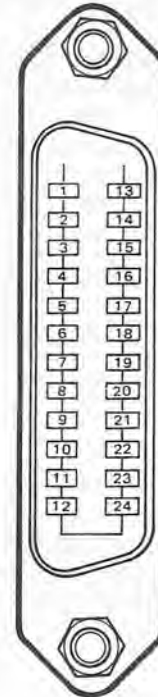

CAUTION

The 5335A contains metric threaded HP-IB cable mounting studs as opposed to English threads. Metric threaded HP 10631A, B, C, or D HP-IB cable lock screws must be used to secure the cable to the instrument. Identification of the two types of mounting studs and lock screws is made by their color. English threaded fasteners are colored silver and metric threaded fasteners are colored black. DO NOT mate silver and black fasteners to each other or the threads of either or both will be destroyed. Metric threaded HP-IB cable hardware illustrations and part numbers follows.

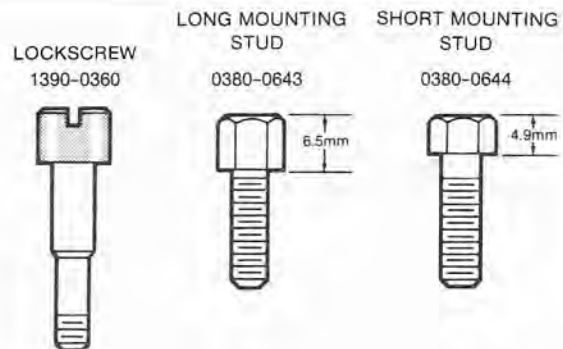

Logic Levels

The Hewlett-Packard Interface Bus logic levels are TTL compatible, i.e., the true (1) state is 0.0V dc to 0.4V dc and the false (0) state is +2.5V dc to +5.0V dc.

Programming and Output Data Format

Refer to Section III, Operation

Mating Connector

HP 1251-0293; Amphenol 57-30240.

Mating Cables Available

HP 10631A, 1 metre (3.3 ft.), HP 10631B, 2 metres (6.6 ft.), HP 10631C, 4 metres (13.2 ft.), HP 10631D, 1/2 metre (1.6 ft.).

Cabling Restrictions

1. A Hewlett-Packard Interface Bus System may contain no more than 2 metres (6.6 ft.) of connecting cable per instrument.
2. The maximum accumulative length of connecting cable for any Hewlett-Packard Interface Bus System is 20.0 metres (65.6 ft.).
3. The maximum number of instruments in one system is fifteen.

Figure 2-3. Hewlett Packard Interface Bus Connection

2-22. 5335A HP-IB Address

2-23. The 5335A contains a rear panel HP-IB instrument address selection switch. There are five switches, designated A₅, A₄, A₃, A₂, A₁ which are used to select the address. Instructions for setting and changing the address are provided in Section III of this manual along with programming codes. When the instrument is turned on, the setting of the address switches is momentarily displayed in decimal.

2-24. HP-IB Descriptions

2-25. A description of the HP-IB is provided in Section III of this manual. A study of this information is necessary if the user is not familiar with the HP-IB concept. Additional information concerning the design criteria and operation of the bus is available in IEEE Standard 488-1978, titled "IEEE Standard Digital Interface for Programmable Instrumentation".

2-26. FIELD INSTALLATION OF OPTIONS

2-27. To obtain the necessary parts for installation of an option, order by part number as listed in *Table 2-1*.

2-28. Field Installation Procedure For Option 010

2-29. To install Option 010, first obtain parts listed in *Table 2-1*, then proceed as follows:

a. Disconnect the power cable from the 5335A (safety precaution).

WARNING

THE AC POWER CIRCUITS TO TRANSFORMER T1 AND THE UNREGULATED DC VOLTAGE ARE STILL ON EVEN WHEN THE POWER SWITCH IS OFF. CONTACT WITH THESE CIRCUITS CAN RESULT IN INJURY TO PERSONNEL OR DAMAGE TO EQUIPMENT.

b. Remove the top and bottom covers of the 5335A.

c. Remove electrical lead (jumper), P/N 8159-0005, that connects A4U1B(6) and U2B(6).

d. Apply power to the 5335A and check all voltages at A4XA15 connector per A4 schematic diagram, especially A4XA15 (14).

e. Disconnect the power cable from the 5335A.

f. Plug the oven oscillator (10544-60011 or 10811-60111) into A4XA15 and secure oven oscillator to A4 assembly from underneath, with two screws (6-32 × 5/16) and fiber washer provided (P/N 3050-0005).

g. Restore top and bottom covers to the 5335A.

h. Apply power to the 5335A and verify counter operation by performing the operational verification in Section IV.

2-30. Field Installation Procedures For Option 020

2-31. To install Option 020, order parts listed in *Table 2-1* or order Retrofit Kit P/N 05335-60220, then proceed as follows:

a. Disconnect power cable from the 5335A (safety precaution).

b. Remove the top and strapped-side cover (right side) of the 5335A.

c. Remove blank panel by removing the two 5/16 nuts that holds the blank panel to the front panel.

d. Install Positive cable assembly, P/N 05335-60110, through the upper hole of the DVM front panel (P/N 05335-00007) and the corresponding hole in the mainframe, and secure the cable and panel with 13 mm (3/8 inch) plastic nut, P/N 2950-0144, to the frame.

e. Install Negative cable assembly, P/N 05335-60111, through the lower hole of the DVM front panel and the corresponding hole in the mainframe, and secure it with plastic nut.

f. Use tie-wraps to bind the positive and negative cable assemblies together.

g. Connect the Positive cable (red/blue) assembly to terminal marked "INPUT" on the circuit side of the DVM board assembly; connect the Negative cable (black) assembly to terminal marked "COM" on same side of board.

h. Install DVM board into A2XA8 connector of the A2 amplifier support board (see assembly locator, *Figure 8-24*); secure A8 with two pozidriv screws to mainframe.

i. Perform Option 020 adjustment as described in *paragraph 5-17*.

j. Replace side and top covers.

Table 2-1. Field Installable Options

| OPTION | DESCRIPTION | DESIGNATOR | PART NUMBER | QTY |
|--------|---|------------|--|-----|
| 010 | A15 Oven Oscillator Assembly 6-32 × 5/16 Screw Fiber Washer | A15 | 10811A | 1 |
| | | | 2360-0115 | 2 |
| | | | 3050-0005 | 2 |
| | Retrofit Kit Number (includes all parts in Option 020) | | 05335-60220 | |
| 020 | A8 DVM Board Assembly DVM Front Panel Positive Cable Assembly Negative Cable Assembly Plastic Nut (3/8 in. – 13 mm) | A8 | 05335-60008 | 1 |
| | | | 05335-00007 | 1 |
| | | A8W1 | 05335-60110 | 1 |
| | | A8W2 | 05335-60111 | 1 |
| | | | 2950-0144 | 2 |
| | Retrofit Kit Number (includes all parts in Option 030) | | 05335-60230 | |
| 030 | A9 Channel C Board Assembly Channel C Front Panel Channel C RF Cable Assembly Channel C Sensitivity Cable Assembly Pre-amp Power Cable Assembly Fuse Holder Teflon insulator Special BNC SMC Connector Hex Nut 0.12A Mini-Axial Fuse Lockwasher Plastic Nut (3/8 in. – 13 mm) | A9 | 05335-60009 | 1 |
| | | | 05335-00008 | 1 |
| | | A9W1 | 05335-60105 | 1 |
| | | A9W2 | 05335-60106 | 1 |
| | | A9W3 | 05335-60109 | 1 |
| | | | 05305-20104 | 1 |
| | | | 05305-20105 | 1 |
| | | | 05305-60205 | 1 |
| | | | 05305-60206 | 1 |
| | | | 0590-0038 | 1 |
| | | | 2110-0301 | 1 |
| | | | 2190-0068 | 1 |
| | | | 2950-0144 | 1 |
| | | | Parts to Retrofit Option 040 include the following: | |
| 040 | Switch Panel Support Assembly Programmable Input Shield 50-ohm Coaxial Cable Front Panel 6-32 × 1/4" Screws | A10 | 05335-60010 | 1 |
| | | A11 | 05335-60011 | 1 |
| | | A12 | 05335-60012 | 1 |
| | | A16 | 05335-20203 | 1 |
| | | W7, W8 | 05335-60112 | 2 |
| | | | 05335-00013 | 1 |
| | | | 2360-0113 | 3 |

2-32. Field Installation Procedures For Option 030

2-33. To install Option 030, order parts listed in Table 2-7 or order Retrofit Kit 05335-60230, then proceed as follows:

- a. Disconnect power cable from the 5335A (safety precaution).
- b. Remove top and strapped-sided cover of the 5335A.
- c. Remove blank panel by removing the two 5/16 inch hex nuts that holds blank panel to the mainframe.
- d. Install Special Input BNC (provided) through the lower hole of the Channel C front panel (P/N 05335-00008) and the corresponding hole in the mainframe, and secure the special BNC and panel with hex nut, P/N 0590-0038, to the frame as illustrated in Figure 2-4.

e. Connect the gold SMC connector on one end of A9W1 to the INPUT C BNC; connect the other end of A9W1 to A9J3.

f. Install Preamp Power Cable assembly (A9W3) through the middle hole of Channel C front panel, and secure it with plastic nut, P/N 2950-0144, to the frame; connect the other end of A9W3 red and white wires to A9J4 (to test pins marked "R" and "W").

g. Install Sensitivity cable assembly (A9W2) through the upper hold of Channel C front panel and secure it with a 5/16 hex nut; install the Channel C sensitivity control knob; connect the other end of A9W2 cable to A9J1.

h. Install A9 Channel C board into A2XA9 connector of the A2 amplifier support board (see assembly locator, Figure 8-24). Secure A9 with a posidriv screw to mainframe. 8-105

- i. Perform Option 030 adjustment as described in paragraph 5-19. 5-17.
- j. Replace side and top covers.

2-34. When Option 030 C Channel is installed, the operator may be required to replace the input BNC fuse. This is a 1/8A fuse (HP Part No. 2110-0301) which is located within the INPUT C BNC connector (see Figure 2-4 for details). To replace the fuse, disconnect the power cord, unscrew the special BNC barrel and, with needle-nose pliers, remove and replace the fuse. Reinstall the BNC barrel, and tighten using a BNC cable connector. Be careful not to over-tighten.

2-35. Field Installation Procedures for Option 040

2-36. To install Option 040, first obtain parts listed in Table 2-1, then proceed as outlined in step b below (removal of the standard module is described in step a). If Option 020 (DVM) and/or Option 030 (C-channel) is

installed, they **MUST** be removed before installing Option 040; reverse the steps of the option's installation procedures as outlined in previous paragraphs. Also, refer to Figure 8-22 Assembly and Cable Locator, during this installation procedure.

- a. Removal of standard module:
 - 1. Disconnect the power cable from the 5335A (safety precaution).

WARNING

THE AC POWER CIRCUITS TO TRANSFORMER T1 AND THE UNREGULATED DC VOLTAGE ARE STILL ON WHEN AC POWER IS APPLIED TO THE INSTRUMENT AND THE POWER SWITCH IS OFF. CONTACT WITH THESE CIRCUITS CAN RESULT IN INJURY TO PERSONNEL OR DAMAGE TO EQUIPMENT.

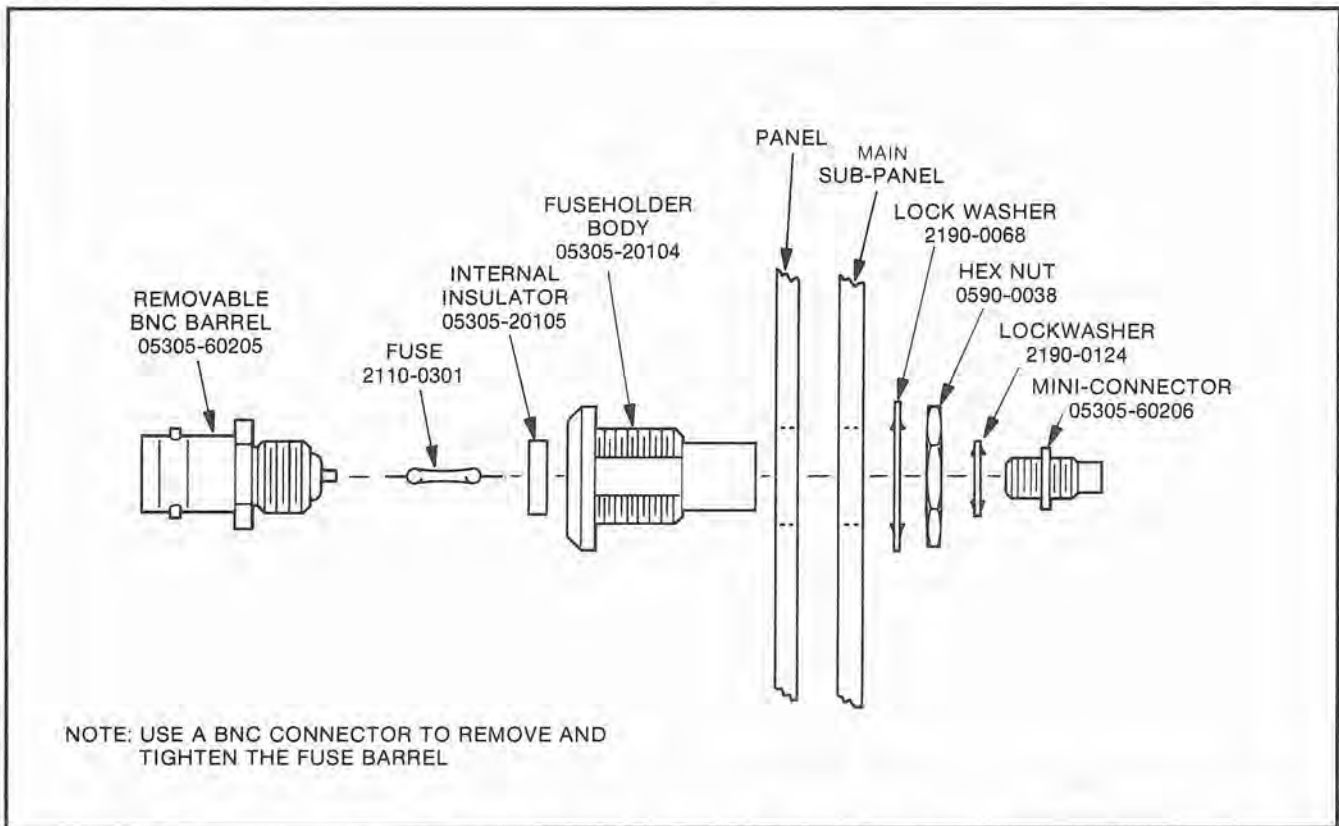

Figure 2-4. Details of Input Connector J1 and fuse Mounting

CAUTION

Static electricity can result in permanent degradation or catastrophic failure of the instrument or assemblies removed from the instrument. All work performed on instruments with covers removed or on assemblies, must be at static safe stations providing proper grounding for the operator.

2. Remove top, bottom, and both side covers of the 5335A.
 3. Remove coaxial cables (P/N 05335-60103 or 05335-60112), that connect A3J6 and A2J3 (Channel A), and A3J1 to A2J4 (Channel B). Please see 5335A-13 Service Note for coaxial cable compatibility.
 4. Remove multiribbon cables W5 (connects A3J5 to A2J1) and W6 (connects A3J2 to A2J2).
 5. Remove W4 Cable Assembly Display which connects A5J1 to A4J3.
 6. Remove A2 Amplifier Support Assembly by first unscrewing the four screws that attach the assembly to the mainframe, then sliding the assembly to the right.
 7. Using a suitable allen wrench, remove channels A and B trigger level control knobs from standard module; also, remove the GATE ADJ control knob. With an appropriate nut driver, remove the hex nuts from A3R66, A3R22, and A5R3 (GATE ADJ).
 8. Remove the two hex nuts from A3J4 (channel A) and A3J3 (channel B).
 9. Remove standard A3 Amplifier Buffer Assembly, by gently pushing the assembly from the front panel inwards.
 10. Remove the standard front panel by removing the hex nut, located on the rear of the A5 Display Assembly, above the ON/STBY switch.
 11. Detach the 5335A front flange by removing the eight screws that affix it to the System II mainframe.
 12. Remove the 13 retainer clips located on the back of the A5 Display assembly. Separate the A5 from the 5335A front flange.
- b. Installation of Option 040:
 1. Attach A10 keyboard assembly to the A5 display board by connecting A10J1 to A5J2.
 2. Insert the A5/A10 assembly combination into the 5335A front flange and attach the thirteen retainer clips that fixes A5/A10 to the front flange.
 3. Position the A10 assembly such that the momentary switches are centered with their respective subpanel openings. Attach the A17 shield, P/N 05335-20203, to the back of A10 keyboard assembly, with the part number of the shield facing the front of the instrument. Secure the shield and the keyboard to the front subpanel with three screws (P/N 2360-0113).
 4. Attach and secure the 5335A front flange to the mainframe.
 5. Install the Option 040 front panel and secure the rear left side of the panel with an 5/16" hex nut with lock (P/N 2420-0001). Secure the right side of panel with the same hex nut removed during disassembly, i.e., to A5R3 GATE ADJ.
 6. Install the A12 Programmable Input Amplifier into the 5335A front panel from the rear; insure that the internal lock washers (P/N 2190-0102) are in place, between A12J6 and A12J3 and the front panel. Secure A12 with the appropriate hex nuts.
 7. Install Channel A and B trigger level control knobs, and the GATE ADJ control knob.
 8. Install A11 Option 040 Support Assembly, P/N 05335-60011, and secure to mainframe.
 9. Connect A5J1 to A4J3 with W4 Cable Assembly Display.
 10. Connect A12J7 to A11J1 with W5 and A12J2 to A11J2 with W6 (multiribbon cables, P/N 1820-2867).
 11. Connect A12J8 to A11J5 with W7 and A12J4 with W8 (coaxial cables, P/N 05335-60112).
 12. Perform Option 040 adjustments as described in Section V.
 13. Replace top, bottom, and side covers on the 5335A.

2-37. STORAGE AND SHIPMENT

2-38. Environment

2-39. The instrument may be stored or shipped in environments within the following limits:

TEMPERATURE -40°C to +75°
HUMIDITY Up to 95%
ALTITUDE .. 7,620 metres (25,000 feet)

2-40. The instrument should also be protected from temperature extremes which cause condensation within the instrument.

2-41. Packaging

2-42. ORIGINAL PACKAGING. Containers and materials identical to those used in factory packaging are available through Hewlett-Packard offices. If the instrument is being returned to Hewlett-Packard for servicing, attach a tag indicating the type of service required, return address, model number, and full serial number. Also, mark the container FRAGILE to ensure careful handling. In any correspondence, refer to the instrument by model number and full serial number.

2-43. OTHER PACKAGING. The following general instructions should be used for repacking with commercially available materials:

- a. Wrap instrument in heavy paper or plastic. (If shipping to Hewlett-Packard office or service center, attach tag indicating type of service required, return address, model number, and full serial number.)
- b. Use a strong shipping container. A double-wall carton made of 350-pound test material is adequate.

CAUTION

The instrument front handles must be left attached to avoid damage to controls.

- c. Use a layer of shock-absorbing material 70 to 100 mm (3- to 4-inch) thick around all sides of the instrument to provide firm cushioning and prevent movement inside container. Protect control panel with cardboard.
- d. Seal shipping container securely.
- e. Mark shipping container FRAGILE to ensure careful handling.
- f. In any correspondence, refer to instrument by model number and full serial number.

SECTION III OPERATION AND PROGRAMMING

3-1. INTRODUCTION

3-2. This section provides the operating and remote programming information for the HP 5335A Universal Counter. It explains the operating characteristics, operating functions, controls, and all modes of operation.

3-3. Description, operating and programming instructions for Options 020, 030 and 040 are provided in this section.

3-4. OPERATING CHARACTERISTICS

3-5. The 5335A is a system and benchtop universal counter. Basic functions include frequency, period, time, ratio, totalize, and volts. Inputs enter two 200-MHz matched amplifiers and are measured by the multiple register counter IC. Raw data from the measurements are used by the counter micro-processor to compute and format the result for display. Extensive triggering and arming of the counter give the user great control over measurements. Math and statistical functions give the user flexibility over how the measurement is displayed. The operating range, resolution and accuracy for each individual functional mode of operation is given in the Specifications, *Table 1-1*.

3-6. Option 040 provides the same basic input circuitry and control as the standard instrument, with the following modifications:

- A digital-to-analog-converter is added to the trigger level circuitry, which allows remote programming of both channel input trigger levels between -5 and $+5$ volts, with 10 mV resolution.
- Relays have been added to the input signal conditioning circuitry, allowing remote programming of the attenuators, input coupling, impedance, trigger level, and low pass filter controls.
- Low Pass Filters have been added to the input buffer circuits. These are selectable via the front panel or the HP-IB.

- Front panel INPUT controls are momentary pushbutton keys, with inset LED indicators to represent status.

3-7. LOCAL OPERATION

3-8. The local operation (vice remote operation) of the HP 5335A is presented through the following subsections:

GENERAL OPERATION INFORMATION. The general operation information describes a variety of functionally nonspecific operating instructions, operating characteristics, and indications. It provides a general overview of the front panel operating controls and indicators.

FRONT AND REAR PANEL FEATURES. The front and rear panel features provides a complete functional description of all operator controls and indicators. This information compliments and expands on the front and rear panel foldouts, *Figures 3-12* and *3-13*.

DETAILED OPERATING INSTRUCTIONS. The detailed operating instructions (starting with paragraph 3-106) present the most comprehensive information about each specific measurement function. They are categorized by the labeled function mode (e.g., *FREQ A*, *PER A*), and provide simple keystroke examples.

3-9. Additionally, the top cover of the instrument provides an Operating Instructions label. This label summarizes the general operating instructions for most of the counter's functions. A copy of the Operating Instructions label is shown on a foldout at the end of this section.

3-10. REMOTE OPERATION

3-11. A description of remote programming operation begins with paragraph 3-167. A good working knowledge of local operation is essential for HP-IB programming, as most of the Data messages contain

the same keystroke-like sequences. Where applicable, throughout this section, program examples are provided. The information within the Remote Operation includes the following:

| | |
|--------------------------------|--------------------------------------|
| General HP-IB Information | Learn Mode Programming |
| Interface Function | SRQ and Status |
| Bus Messages | Program Execution/ Response Times |
| Address Selection | Output Format |
| Device Command Definitions | Output Modes |
| Device Commands | Programming Examples |
| Default and Power-up States | |

3-12. OPERATORS SELF-CHECK PROCEDURE

3-13. This section, beginning with paragraph 3-248, includes checks that allow the operator to make a quick evaluation of the counter's operation. These checks will fundamentally verify the following:

- Keyboard
- Display and Annunciators
- Memory; RAM and ROM
- HP-IB

3-14. GENERAL OPERATION INFORMATION



BEFORE THE INSTRUMENT IS SWITCHED ON, ALL PROTECTIVE EARTH TERMINALS, EXTENSION CORDS, AUTOTRANSFORMERS AND DEVICES CONNECTED TO IT SHOULD BE CONNECTED TO A PROTECTIVE EARTH GROUNDED SOCKET. ANY INTERRUPTION OF THE PROTECTIVE EARTH GROUNDING WILL CAUSE A POTENTIAL SHOCK HAZARD THAT COULD RESULT IN PERSONAL INJURY.

ONLY 250V FUSES WITH THE REQUIRED RATED CURRENT AND SPECIFIED TYPE SHOULD BE USED. DO NOT USE REPAIRED FUSES OR SHORT CIRCUITED FUSEHOLDERS. TO DO SO COULD CAUSE A SHOCK OR FIRE HAZARD.

3-15. Power-Up/Self-Check

3-16. When the counter is turned on, an internal check is made of several major components in its circuitry. During this cycle, all front panel number display segments and indicators will light momentarily, followed by the momentary display of the instrument's decimal HP-IB address (e.g., HP-IB Addr 28).

3-17. After the power-up sequence, the counter will initialize itself. All math and statistics will be off, the function will be Frequency A, and the gate and cycle modes will be in Norm. All of the input controls will be set according to their switch positions.

3-18. Any failures during the power-up cycle will disable the counter and produce a display of numbered error or fail messages. Within the 5335A, fail messages generally indicate a hardware failure, and error messages indicate the user has attempted an improper operation. Refer to Error Messages, paragraph 3-252.

3-19. Display

3-20. The number to be displayed is formatted in engineering notation with the digits grouped into threes for convenient reading and an exponent. When displaying 11 and 12 digit numbers, the grouping is omitted. The number of digits displayed is determined by the FUNCTION and GATE time. In most cases, a longer gate time gives more digits.

3-21. When resolution calls for more than 12 digits no overflow results. Instead, the most significant digits are retained, and the display is reduced to 12 digits.

3-22. The exponent range of the display is ± 18 . If a number cannot be displayed the display will show one of these two numbers.

- 0. +19 (0×10^{19})
if the number is too large.
- 0. -19 (0×10^{-19})
if the number is too small.

NOTE

If you suddenly see two less digits in frequency, period, or time interval measurements, there may be a failure in the interpolators. If you press RESET you may get these digits back, or you may get a FAIL message. See the section on diagnostics in Section VIII.

3-23. Annunciators indicate the Hz (hertz), S (seconds), and V (volts) units. For some functions the units are not indicated, but assumed, such as degrees for phase measurements. For slew rate, both the Volts and Seconds annunciators are on to indicate Volt/second.

3-24. The GATE light shows the status of the counter gate. Before the measurement starts, this light is off, indicating that the gate is closed. During the measurement, the light is on, indicating that the gate is open.

3-25. The TALK, LISTEN, SRQ, and REMOTE lights monitor the status of the HP-IB. Refer to Programming, paragraph 3-167.

3-26. Keyboard

3-27. The keyboard is divided into several groups, according to the purpose of the keys. From the left, we have MATH/STATISTICS, FUNCTION, GATE ADJ/CYCLE MODE, INPUT, and if installed, INPUT C (Option 030), and VOLTS (Option 020). With exceptions, each group operates nearly independently of the others. The operation of each front panel key, within each keyboard group, is presented in Front Panel Features, beginning with paragraph 3-38.

3-28. Key Indicators

3-29. The operation of individual keys is relatively straightforward. Indicator LED's, in the center of many keys, represent that key status. A steady "on" LED indicates that the key labeled function is active or in-effect. An "off" LED indicates that the key's labeled function is not active or disabled. Many keys operate in a toggle on/off fashion. The blue colored keys in the MATH function group can be programmed. A "blinking" LED within a blue key is used as a "prompt" for the operator. It indicates that it is waiting for a data entry. Number entries are made from the keys labeled in blue. Refer to paragraph 3-82.

3-30. Keyboard Memory

3-31. To avoid having to reenter math constants, etc., whenever switching between two functions repetitively, the keyboard has one level of memory. This allows you to set up two functions modes, each with their own set-ups. The key set-ups for each of the keys in the MATH, STATISTICS, FUNCTION, GATE, and CYCLE groups are automatically memorized. Controls within the INPUT group are not memorized.

3-32. Reading the convenience functions GATE TIME or TRIG LVL will not affect the keyboard memory. Any

changes to the key set-ups while in these functions will be carried back to the set-up of the function that was active before. GATE TIME and TRIG LVL are not affected by MATH and STATISTIC functions. For example:

1. Presently in FREQ A, we enter an OFFSET of 123.
2. Later we switch to PER A, where we see by the OFFSET key indicator, that the OFFSET is off.
3. Then later selecting FREQ A, we see that the OFFSET is again 123.
4. We then select TRIG LVL, and then GATE TIME.
5. While in GATE TIME we set the GATE MODE to FAST.
6. Returning to FREQ A, we still have an OFFSET 123, but also, the GATE MODE is now in FAST.
7. We select PER A, then PULSE A. Now, when we return to FREQ A, all set-ups go to the default positions.

3-33. Key Default

3-34. The initialized and/or default positions for all operator keys and controls are as follows:

| | | |
|---------|---|--|
| Default | { | MATHOFF STATISTICSOFF RANGE HOLDOFF EXT ARM ENABLEOFF CYCLENORM GATE MODENORM GATE MODEMIN (for TIME, 1/TIME, RISE/FALL, SLEW, DUTY CYC, PHASE) |
|---------|---|--|

| | | |
|---------------------|---|--|
| Initialize Power-Up | { | FREQ A GATE MODENORM CYCLENORM RANGE HOLDOFF EXT ARM ENABLE ...OFF MATHOFF STATISTICSOFF INPUT ... REAR } As set by controls |
|---------------------|---|--|

3-35. Special Function Mode

3-36. The front panel controls allow for a direct, key-per-function selection from 16 labeled function operations. A sequence of keystrokes will allow the operator to enter a *Special Function Mode*, in which the original 16 functions, plus 4 additional unlabeled functions and an extensive diagnostic mode can be accessed. The four unlabeled “phantom” functions are:

FREQ B
PULSE B
TIME A→B
TOTALIZE A-B

3-37. The diagnostic mode allows the user considerable flexibility during troubleshooting through a set of discrete, self-diagnostic test routines. A more complete description of the Special Function Mode and complete procedures using the diagnostic routines are provided in Section VIII.

3-38. FRONT PANEL FEATURES

NOTE

To enhance the descriptions of Front Panel features, fold out *Figure 3-12*, while reviewing these paragraphs.

3-39. The front panel controls, indicators, and connectors are located and briefly described in *Figure 3-12*. A good quick reference of the operating details for each function mode is provided in the Function Key Reference Summary, *Table 3-2*.

3-40. The following paragraphs describe the general purpose and use of the operator keys and controls. They are discussed by functional grouping, as follows:

- FUNCTION GROUP
- GATE CYCLE GROUP
- INPUT GROUP
 - Input Amplifier (Standard Instrument)
- INPUT GROUP
 - (Programmable Input Amplifier — Option 040)
- TRIGGERING (MANUAL/AUTO)
- MATH GROUP
- STATISTICS GROUP
- INPUT C (OPTION 030)
- VOLTS (OPTION 020)

3-41. FUNCTION Group

3-42. Function selection for the HP 5335A is done via a simple key-per-function keyboard. Sixteen function modes (labeled in black) are directly accessible from the four leftmost columns of keys. The indicator LED within the key identifies which one of the functions is active. Several more functions are available, accessed through the HP-IB, and other means (see Special Function Mode, paragraph 3-35, and Diagnostics in Section VIII). During the programming sequence for the MATH group, the functions of these 16 keys (and CHECK) are reassigned to the numeric and special entry values labeled in blue.

3-43. Within the FUNCTION group, the rightmost column has four keys with functions that are described in the following four paragraphs. *Figure 3-1* shows the FUNCTION group keys.

3-44. The RESET key will reset the counter and start a new measurement. When pressed, all segments and decimal points in the display should light, momentarily. RESET will not affect any current function selection or key set-ups. If you are currently in GATE TIME or TRIG LEVELS, pressing RESET returns you to the function you were previously in.

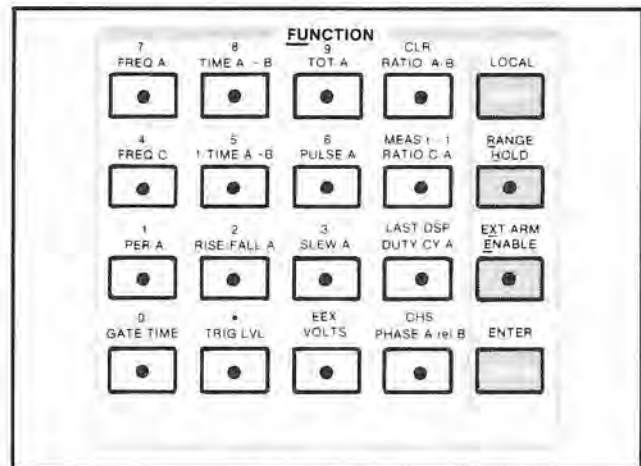

Figure 3-1. Function Group Keys

3-45. RANGE HOLD can be used to freeze the decimal point placement and exponent value of the display. Least significant digits are allowed to “fall off” the right of the display. However, the display is programmed to avoid a loss of the most significant digit. RANGE HOLD is useful when the value in the display is rapidly changing in magnitude. In the PHASE A rel B mode, RANGE HOLD will select and maintain the 0° to 360° measurement display range. RANGE HOLD toggles on and off with each press of the key.

3-46. The EXT ARM ENABLE key is used to enable or disable external arming of measurements. When it is on, the Start and/or Stop of the measurement can be armed by a signal connected to the rear panel. When EXT ARM ENABLE is off, the counter ignores the rear panel signal. EXT ARM ENABLE toggles on and off with each press of the key.

3-47. The CHECK key puts the instrument into one of two levels of internal self-check programs. Pressing the key once will enter a “lamp test loop” flashing all front panel annunciators, key indicators and segments, checking the MRC, and memory circuits. Pressing and holding the key (for approximately 3 seconds) will place the instrument into an extended diagnostic loop of several major circuits (i.e., amplifiers, time base, counting circuitry, and display). This extended test requires that the user connect the rear panel Time Base Out to the Channel A input, put both channels to 50 Ω , and remove any signal to Channel B. See Operational Verification section for further details. Any failures during the diagnostic loop will result in the display of either a numbered FAIL or ERROR message. FAIL messages generally indicate a circuit failure. ERROR messages indicate the user has attempted an improper operation; for example, a misspelled HP-IB command. Refer to ERROR MESSAGES, paragraph 3-252. To exit either self-check routine, press any other function key.

3-48. GATE/CYCLE Group

3-49. The GATE ADJ control sets the length of the gate time, continuously adjustable through the ranges set by the GATE MODE keys. In certain time interval functions (i.e., TIME A→B, 1/TIME A→B, PULSE A), the actual gate time is automatically determined, dependent on the input signal. In these modes, the gate time controlled by GATE ADJ, can be used as a Hold-Off Delay for the Stop channel. If a T.I. DELAY mode is selected (any GATE MODE except MIN) the T.I. DELAY indicator will light. In these functions, the normal operation gate mode is MIN if no delay is desired. For more information about the GATE ADJ control during time domain measurements, refer to TIME A→B, paragraph 3-115. Figure 3-2 shows the GATE and CYCLE controls.

3-50. Gate mode NORM and FAST are two ranges of adjustable gate times. NORM has a range of nominally 20 milliseconds to 4 seconds, and FAST has a range of nominally 100 microseconds to 20 milliseconds. The one key causes the mode to toggle between NORM and FAST.

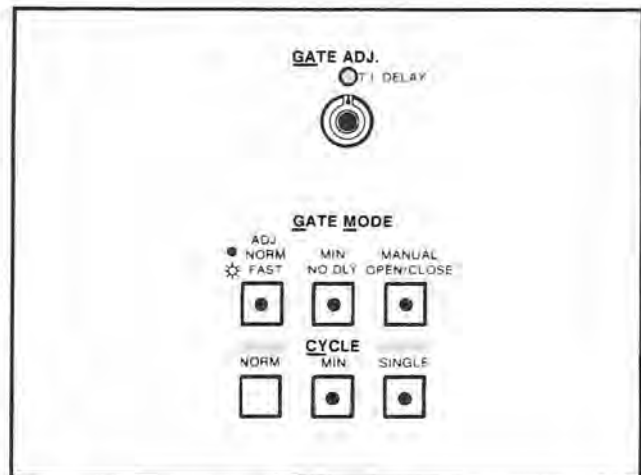

Figure 3-2. GATE and CYCLE Controls

3-51. Gate mode MIN (minimum) NO DLY (no delay) specifies the shortest possible gate time. This means that the signal itself usually determines the time. For example, the Frequency A measurement uses a divide-by-two prescaler. The gate time in this function would be determined by two periods of the input. MIN mode is usually the mode used when External Stop Arm is used.

3-52. The MANUAL OPEN/CLOSE key lets you specify the gate time manually. In the manual mode, each press of the key toggles the gate either open or closed. The status of the gate is indicated by the GATE annunciator. Manual mode allows very long gate times.

3-53. CYCLE mode NORM key specifies about a 250 milliseconds wait time between measurements. This slows the display down to a rate that is more convenient for viewing short gate time measurements.

3-54. CYCLE mode MIN (minimum) mode tells the counter to start the next measurement as soon as possible. This gives the most rapid updating of the display.

3-55. CYCLE mode SINGLE key lets you start measurements upon manual command. Each press of the key starts one measurement. This measurement stays on the display until the key is pressed again (RESET will also start a new measurement).

NOTE

Remember that this counter uses synchronized gating, and that the input signal also determines the length of the gate time. Additionally, several modes of Arming are available, see Rear Panel Features.

3-56. INPUT Group (Standard Instrument)

3-57. The INPUT group contains the A Channel and B Channel input BNC's, signal conditioning controls, and triggering controls. Figure 3-3 shows the INPUT group controls.

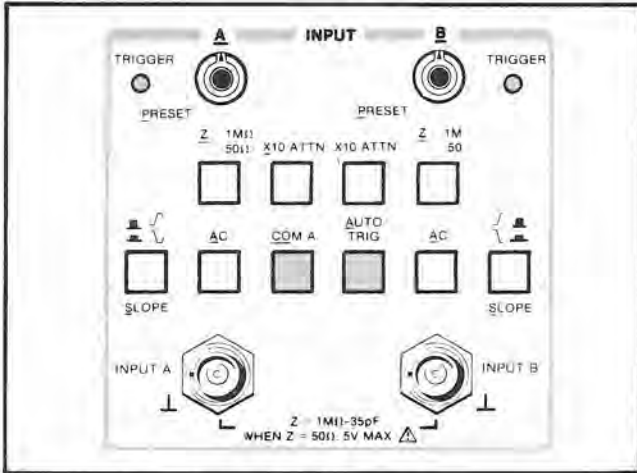

Figure 3-3. INPUT Group Controls

3-58. The SLOPE key determines which edge of the signal to trigger on. For some functions it also takes on other uses. For PULSE, the Slope A switch is used to specify the positive (\nearrow) or negative (\searrow) pulse. For RISE/FALL, it is used to specify whether it is RISE or FALL time being measured. SLOPE A has a similar purpose for SLEW. For DUTY CYC, it determines whether to display the percentage high (\nearrow) or low (\searrow).

NOTE

All keys in the INPUT group must be pressed to where they latch in to enable the operation of the key as it is labelled. To discontinue an operation the key must be pressed again so the key releases out.

3-59. The AC key, when pressed, makes the respective input amplifier ac (capacitor) coupled. This is useful for ignoring dc offsets on a signal.

3-60. The input impedance of each channel is selected by the Z = 1MΩ/50Ω key.

3-61. For inputs greater than the five volt dynamic range, or to reduce the sensitivity of the front end, the X10 ATTN key lets you attenuate the signal by a factor of 10. The damage level still applies, however, when Z=50Ω. For convenience, the trigger level reading function will arithmetically multiply the display by ten when the attenuators are on.

3-62. INPUT Group (Option 040)

3-63. The addition of Option 040 affects only the INPUT section of the front panel controls. The INPUT group contains the A Channel and B Channel input BNC connectors, signal conditioning and triggering controls. The operation of all the pushbutton keys within this section is the same. The keys operate in a toggle on/toggle off fashion. An indicator LED in the center of each key represents the keys status. A steady "on" LED indicates that the keys labeled function is active or in-effect. An "off" LED indicates that the opposite or reciprocal function is active or in effect. For example, when the INPUT A FILTER key is pressed, that keys LED lights indicating the low pass filter is activated for INPUT A. Conversely, if the FILTER keys LED is disabled. The following paragraphs describe the operation and function of each control. Figure 3-4 shows the Option 040 INPUT group controls.

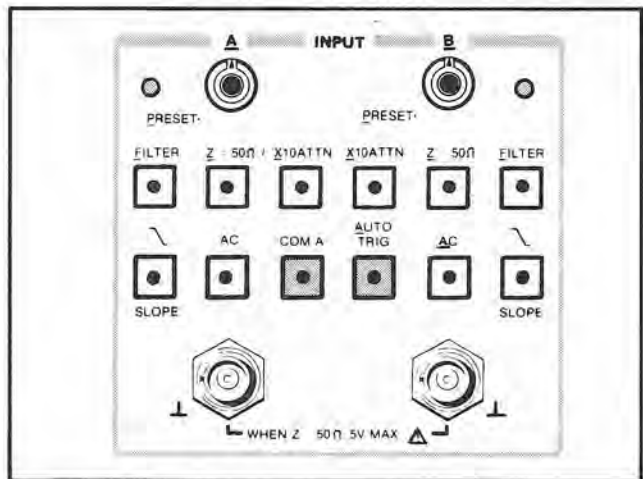

Figure 3-4. Option 040 INPUT Group Controls

3-64. The SLOPE key determines which edge of the input signal the channel will trigger on. For some functions it also takes on other uses. For PULSE, the SLOPE A key is used to specify the positive (LED off) or negative (LED on) pulse. For RISE/FALL, it is used to specify whether it is RISE or FALL time being measured. SLOPE A has a similar purpose for SLEW. For DUTY CYC, it determines whether to display the percentage high (LED off) or low (LED on).

3-65. When the positive slope is selected, the key indicator LED will be unlighted. When the negative slope is selected, the key indicator LED will be lighted.

3-66. The AC key selects either AC or DC coupling for the associated input amplifier. When DC coupling is selected, the key indicator LED will be unlighted.

When AC coupling is selected, the key indicator LED will be lighted.

3-67. The COM A key selects either the separate or common mode for the A and B INPUTS. INPUTS. When Separate is selected, the key indicator LED will be unlighted. When Common is selected, both inputs are directed through the INPUT A channel, and the key indicator LED will be lighted.

3-68. The AUTO TRIG key selects either the MANUAL or AUTO triggering modes. The MANUAL TRIG modes use the trigger adjustment control to set the trigger level between +5 and -5 volts, or to 0 volts when in PRESET. The AUTO TRIG modes reference the range of trigger level adjustability to the level of the input signal, with the peaks of the input signal nominally setting the control limits. The AUTO TRIG PRESET mode automatically sets the trigger level to the 50% point of the input signal, regardless of the dc offset of the input.

3-69. When MANUAL TRIG is selected, the key indicator LED will be unlighted. When AUTO TRIG is selected, the key indicator LED will be lighted.

3-70. The FILTER key activates a low pass filter for the associated channel. The filter attenuates frequencies above 100 kHz, with 175 kHz as NOMINAL cutoff (3 dB point) and >30 dB down at 200 MHz.

3-71. When FILTER is selected, the key indicator LED will be lighted. When FILTER is bypassed, the key indicator LED will be unlighted.

3-72. An input impedance of either 50 Ω or 1 M Ω , for each channel, is selected by the Z=50 Ω key. When 50 Ω is selected, the key indicator will be lighted. When 1 M Ω is selected, the key indicator will be unlighted.

3-73. An attenuation factor of either X1 or X10, for each input channel, is selected by the X10 ATTN key. For inputs greater than the 5V dynamic range, or to reduce the sensitivity of the front end, an attenuation factor of X10 can be selected. For convenience, the trigger level reading function will arithmetically multiply the display by 10 when a X10 attenuator is on. When X1 is selected, the input signal not attenuated and the key indicator LED will be unlighted. When X10 is selected, the input signal is attenuated by ten and the key indicator LED will be lighted.

3-74. Triggering (MANUAL/AUTO)

3-75. The HP 5335A has an extensive set of triggering features which make accurate measurements on input signals easier for the user. Four modes of triggering, listed below, are directly accessible from the front panel or via the HP-IB. A fifth mode (see paragraph 3-80) is automatically selected when in the RISE/FALL A or SLEW A function modes.

Manual Adjustable
Manual PRESET
Auto Adjustable
Auto PRESET

3-76. The Manual Adjustable mode uses the trigger adjustment controls to set the trigger level anywhere between +5 and -5 volts. The actual trigger levels for both channels can be monitored by pressing the TRIG LVL function key. When the control is fully ccw (into detent) the Manual PRESET mode is selected, and the trigger level is set to zero volts.

3-77. When the Auto Trigger mode is selected, the trigger adjustment controls assume a wholly different meaning. Pressing the AUTO TRIG key selects the Auto Adjustable triggering mode. The range of adjustability for the control is now dependent on the amplitude of the input signal, with the peaks of the input signal nominally setting the control limits. See Figure 3-5.

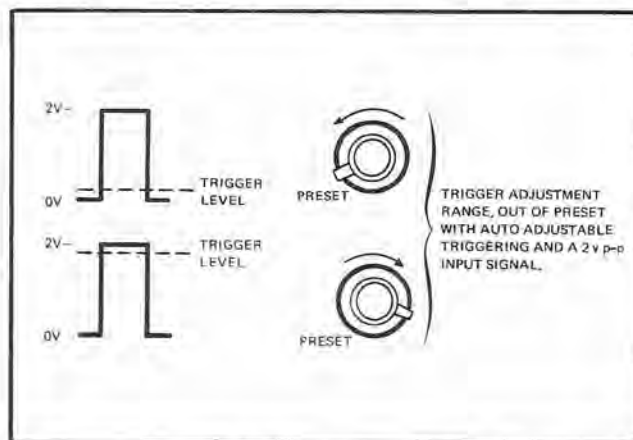

Figure 3-5. Auto-Triggering Range

3-78. Assume, for example, an input signal of two volts peak-to-peak, with Auto Adjustable triggering selected. The range of the trigger adjustment control outside of PRESET will automatically reduce from ± 5 volts to $0V \rightarrow +2V$. This allows a much finer control over the trigger level setting. The actual trigger levels for both channels can be monitored by pressing the TRIG LVL function key.

3-79. Pressing the AUTO TRIG key, with the trigger adjustment control in PRESET, selects the Auto PRESET triggering mode. In this mode, peak detectors on both channels determine the peaks of the input signal. The trigger level is automatically set to the 50% point of the peaks, regardless of the dc offset of the input. *Figure 3-5* shows the AUTO triggering range without PRESET. *Figure 3-6* shows AUTO triggering with PRESET selected.

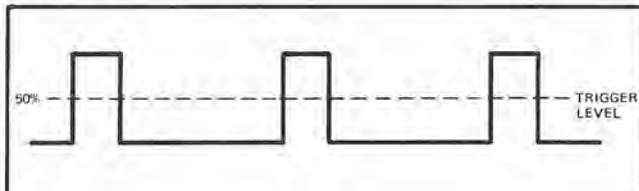

Figure 3-6. Auto Triggering With PRESET Selected

3-80. An additional mode of triggering is used by the functions RISE/FALL A and SLEW A. The peaks of the input signal are determined and the 10% and 90% points are found. These dc levels are assigned as trigger levels by the respective SLOPE keys, to Channels A and B. Pressing TRIG LVL will display the 10% and 90% levels determined.

3-81. The front panel three-state TRIGGER lights provide a visual indication of each channel triggering status. When the light is on, the trigger level is set too low (or the signal is too high). When the light is off, the trigger level is set too high (or the signal is too low). When the light is flashing, the trigger level is set within the peak limits of the input signal (\pm the hysteresis offset of the input amplifier) and the channel is triggering. *Figure 3-7* shows the INPUT TRIGGER indicator lights response to input signals at different trigger level settings.

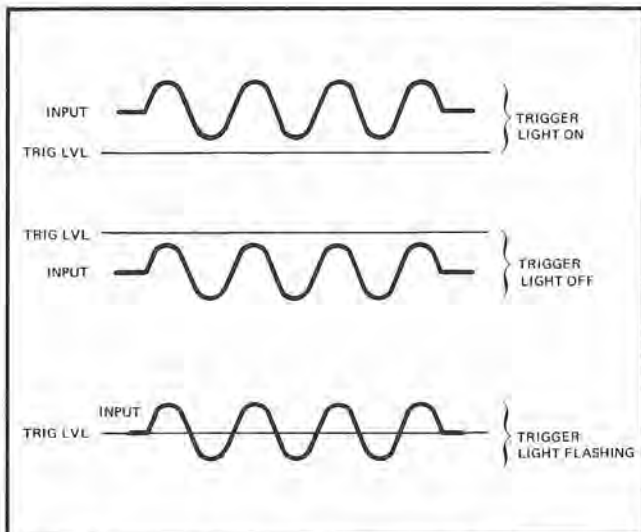

Figure 3-7. Trigger Indicator Light Response

3-82. MATH Group

3-83. The functions within the MATH group allow the user to perform a number of mathematical operations on the measurement before it is displayed. The OFFSET, NORMLZ, and SCALE keys allow for the addition, division, and multiplication, respectively, of the measurement by user specified constants. Modification of the display by the Math operations is represented by the following relationship:

$$\text{Display} = \frac{\text{Measurement} + \text{OFFSET}}{\text{NORMLZ}} \times \text{SCALE}$$

3-84. Notice that the OFFSET operation is performed before normalization and scaling. Any single or combination of these operations can be selected. This provides the user with extensive control over the resultant display. It can be used, for example, to subtract systematic errors or display the percentage difference. Additionally, the overall MATH operation can be disabled and then re-established without having to re-enter constants. *Figure 3-8* shows the MATH and FUNCTION keys.

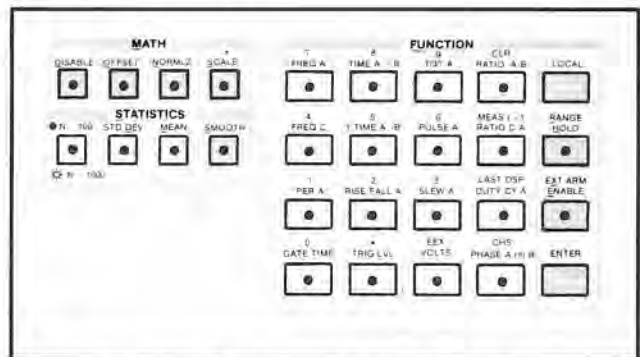

Figure 3-8. MATH and FUNCTION Keys

3-85. ENTERING CONSTANTS. The values for the three user specified constants are entered from the keyboard. Entry begins by pressing any one of three blue keys, OFFSET, NORMLZ, or SCALE. The selected indicator key light will start to flash, indicating that an entry is expected. During the number entry mode, the FUNCTION keys respond to the functions labeled in blue (see *Table 3-1*). Any entry is completed by pressing the ENTER key, at which time the blue key light will turn on (steadily), indicating that a constant for that operation is stored and in effect. After pressing ENTER, the instrument will immediately begin making measurements, performing the MATH operation and displaying the result.

NOTE

Numbers greater than 9×10^9 and less than 1×10^{-9} in magnitude can not be stored.

Table 3-1. Function Key Use During Number Entry

| FUNCTION KEY | FUNCTION DURING NUMBER ENTRY | | | | | | |
|----------------------------|---|----------------------------|-----------------------|---------|-----------|-----------|---|
| 0-9, “.” | Digit entry. Before EEX is pressed, these are used to enter the mantissa value. Up to 11 digits are allowed. After EEX is pressed, these are used to enter the exponent value. | | | | | | |
| EEX | Enter Exponent. Begins exponent entry when pressed. | | | | | | |
| CHS | CHange Sign. Toggles the sign of the mantissa or exponent, depending upon whether EEX was pressed. | | | | | | |
| CLR | CLearRs entry. | | | | | | |
| ENTER | Completes entry of number. After ENTER is pressed, the instrument goes back to making measurements. If the value entered was zero, the specified constant is switched “off”. This is indicated by turning the key’s LED off. If the value entered was not zero, the specified constant is switched “on”. This is indicated by the key LED on. When a constant is “off” it is ignored in the equation. | | | | | | |
| RESET | During number entry, RESET can be used to abort the entry and return to normal operation. | | | | | | |
| DISABLE (in MATH group) | During number entry, this key produces the same effect as entering zero as the value. The specified constant is switched off and normal operation begins. ENTER does not have to be pressed. | | | | | | |
| SPECIAL NUMBER ENTRY KEYS | | | | | | | |
| LAST DISP | This key will put on the display the value that was displayed from the last measurement. If you are presently entering a value to OFFSET, the last display value is negated. This lets you conveniently subtract errors or values based on measurements you’ve made. For NORMMLZ and SCALE, the last display value is not negated. | | | | | | |
| MEAS t-1 | <p>This key does not specify any unique value, but instead specifies that as each measurement is made, the previous measurement value be used (before any mathematical manipulation).</p> <table border="0" data-bbox="472 1042 1375 1114"> <tr> <td style="text-align: center;">Previous measurement (t-1)</td> <td style="text-align: center;">this measurement (t0)</td> <td style="text-align: center;">display</td> </tr> <tr> <td style="text-align: center;">1 2 3 4 5</td> <td style="text-align: center;">1 2 3 4 6</td> <td style="text-align: center;">1</td> </tr> </table> <p>This is an example of MEAS t-1 with OFFSET. As with LAST DISP, the value is negated for OFFSET, and not for NORMMLZ and SCALE.</p> | Previous measurement (t-1) | this measurement (t0) | display | 1 2 3 4 5 | 1 2 3 4 6 | 1 |
| Previous measurement (t-1) | this measurement (t0) | display | | | | | |
| 1 2 3 4 5 | 1 2 3 4 6 | 1 | | | | | |

3-86. REVIEWING CONSTANTS. To review the constants, press any of the blue keys. The counter will cease taking measurements and the presently specified value of the constant will be displayed. The indicator light within the blue key specified will be flashing. At this time, either the value of the constant can be changed by keying in the new number and press ENTER, or all of the constants can be reviewed by pressing each blue key in succession. To return to the measurement mode, press either RESET or ENTER.

3-87. DISABLING MATH OPERATIONS. When not in the number entry mode (i.e., a blue key has not been pressed) the DISABLE key can be used to momentarily turn off all of the MATH functions. The DISABLE function toggles between on and off with each press of the key. The DISABLE key indicator light turns on when the MATH functions are disabled and off when the MATH functions are enabled. While disabled, the indicator lights within the individual MATH function keys are turned off.

3-88. During the number entry mode (i.e., pressing any blue key) the DISABLE key produces the same effect as entering zero (or one) as the value of the constant. The specified MATH function is turned off and the counter begins normal measurements. The ENTER key does not have to be pressed and the remaining MATH functions (if previously loaded) are reinstated.

3-89. If DISABLE is on and a blue key is pressed (number entry mode) the disable condition is defeated for the specified MATH function *only*. A new constant can be entered, and when ENTER is pressed, the measurement is displayed with only that specified MATH function activated. The remaining functions, though programmed with constants, are still DISABLED. To reactivate these stored functions, recall each (by pressing the blue key) and then press ENTER.

3-90. SAMPLE MATH OPERATIONS. The following examples illustrate the operation of the MATH GROUP functions.

a. With an input frequency of 10.001 MHz, enter an an offset of -10 MHz:

Keystrokes: OFFSET CHS 1 EEX 7 ENTER
Measured value: 10.001 MHz
Displayed value: 1 kHz

b. Suppose you are currently measuring a 3.56 MHz color TV crystal. To set -3.56 MHz as the offset:

Keystrokes: OFFSET LAST DISP ENTER
-3.56 E6 will be displayed
Measured value: 3.56 MHz
Displayed value: 0 Hz

c. Suppose in the above example you wished to display percentage error instead:

Keystrokes: OFFSET LAST DISP ENTER
-3.56 E6 will be displayed
DISABLE (lets 3.56 MHz be displayed without the offset)
NORMLZ LAST DISP ENTER
3.56 E6 is now in NORMLZ
SCALE 1 0 0 ENTER (100 is now in SCALE)
OFFSET ENTER (turns OFFSET on again)
Measured value: 3.61 MHz
Displayed value: 1.4045 (percent error from 3.56 MHz)

d. To display an measurement in rpm (revolutions per minute):

Keystrokes: SCALE 6 0 ENTER
Measured value: 100
Displayed value: 6.000 E3

e. To show change in frequency per second (approximately, averaged over 1-second gate times):

Set Gate Adjust to a 1-second gate time, and CYCLE Mode to MIN.
Keystrokes: OFFSET MEAS t-1 ENTER
A "t-1" will be displayed
Measured value: 1000 Hz
Measured value: 1002 Hz
Displayed value: 2 Hz

Measured value: 1005 Hz
Displayed value: 3 Hz

More precise timing of the gate can be achieved by arming.

3-91. STATISTICS Group

3-92. The functions within the STATISTICS group allow the user to automatically accumulate and sample 100 (or 1000) measurements and then determine and display either the standard deviation or the mean (average) of the sampling. These functions are selected by the STD DEV and MEAN keys, respectively, which toggle on and off with each press of the key. The indicator light will light when the function is activated. The sample size is initially set (default state) to 100. Pressing the N=100/N=1000 key will alternately toggle the sample size between 100 and 1000. The indicator light within the key will be on for a sample size of 1000, and off for 100. Figure 3-9 shows the STATISTICS group keys.

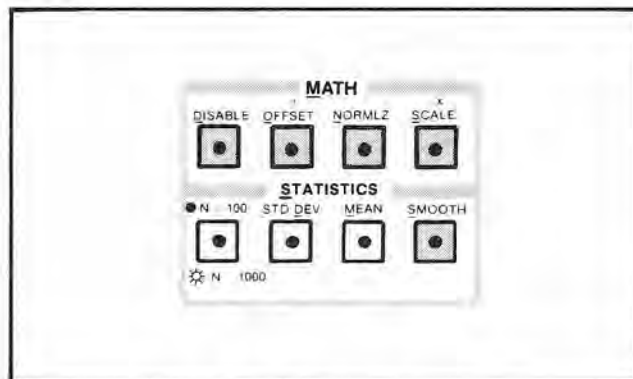

Figure 3-9. STATISTICS Group Keys

NOTE

MATH calculations are done *before* statistics when both are activated.

3-93. Selecting MEAN produces one additional digit of resolution. Selecting STD DEV will display three digits for either sample size. Both the Standard Deviation and the Mean can be displayed for a single sample. To do this the measurements must be made with STD DEV on and the CYCLE MODE set to SINGLE. At the end of the N measurements (100 or 1000) the standard deviation is displayed. Then press MEAN to display the mean of the sample. The mean value is displayed with a resolution based on the standard deviation.

NOTE

Statistical calculations sometimes use data from the measurement that is not displayed, from the resolution lost when a number has to be rounded to the best decade.

3-94. The SMOOTH key selects a unique function which "smooths" the display for easier reading. When SMOOTH is on, the counter looks at the resultant measurement and displays only the digits that are relatively stable. In addition, as the measurements continue to cycle, a running average is made to remove small deviations. The running average is made by assigning each new measurement a weight of 1/10, and the last display 9/10.

Smooth Display = 1/10 New Measurement + 9/10 Last Display

3-95. This allows for slow drift in the signal, but filters out small transients. The SMOOTH function provides a simple visual way to monitor the stability of a signal. If the stability of the signal decreases, the LSD's of the display will correspondingly begin to blank out. As stability increases, the lost digits of resolution will reappear. The SMOOTH key toggles on and off, and operates independently of all other functions.

NOTE

Because Phase measurements require a steady signal input, the use of Statistics is not valid (i.e., the STD DEV of a steady signal should be 0, and MEAN should be the same as any one measurement). Therefore, the use of STATISTICS for PHASE measurements is not recommended.

3-96. INPUT C (Option 030)

3-97. The INPUT C group contains the C Channel Input BNC, SENSITIVITY control and PREAMP POWER receptacle. The input connector is a special fused BNC. Refer to paragraph 3-221 for replacement instructions. The SENSITIVITY control varies the input sensitivity from MAX (10 mV for 150 MHz to 1.0 GHz, 100 mV for 1.0 GHz to 1.3 GHz), refer to Specifications, Table 1-1 for greater than 500 mV. The PREAMP POWER jack allows the use of an optional high frequency broadband preamplifier, such as the HP 10855A. The GATE ADJ and GATE MODE controls operate as with A Channel. Figure 3-10 shows the Input control panel.

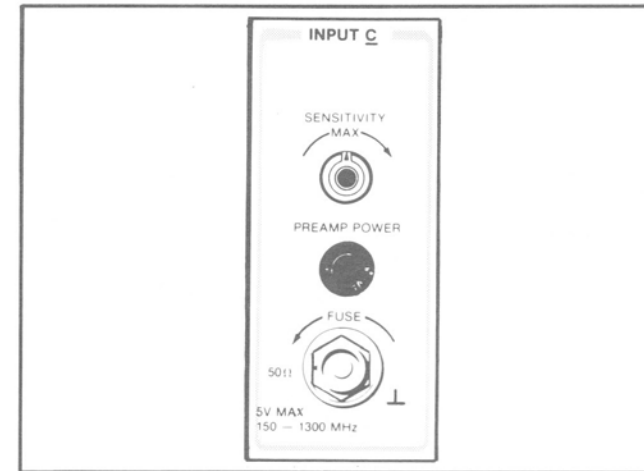

Figure 3-10. INPUT C Control Panel

NOTE

The PREAMP POWER jack supplies $\approx +15$ Vdc and a ground output. This connector will not support a three-wire type power probe.

3-98. VOLTS (Option 020)

3-99. The VOLTS section contains the DCV (Red) and COM (Black) input connectors for the fully floating, autoranging Digital Voltmeter. The voltmeter measures dc inputs up to ± 1000 volts. It automatically selects the ± 10 V, ± 100 V, or ± 1000 V range, depending on the input voltage. The sensitivity is $100 \mu\text{V}$ to 100 mV (depending on the range). Figure 3-11 shows the VOLTS (digital voltmeter) control panel.

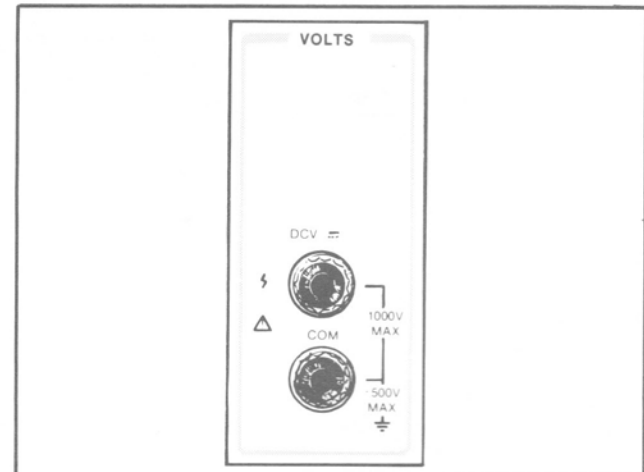

Figure 3-11. VOLTS Panel

The MATH keys provide for post-measurement manipulation of the display, by the mathematical operations of OFFSET (\pm), NORMALIZE (\div), and SCALE (\times). Values for constants are programmed in via the numeric values of the FUNCTION keys.

The Function keys provides the key-per-function selection of 16 basic function modes, as well as RESET, RANGE HOLD, EXT ARM, and CHECK.

The counter numeric display, providing 12 possible digits of mantissa, an exponent sign (\pm), and an engineering notation exponent (0, ± 3 , ± 6 , ± 9 etc.) Mantissa digits are grouped into threes for convenience, whenever possible.

The GATE ADJ control provides the adjustability for the GATE MODES, and for adjustment of the T.I. Delay holdoff.

The display ANNUNCIATION group provides LED indicators for monitoring the status of the Gate, HP-IB, and units of the measurement.

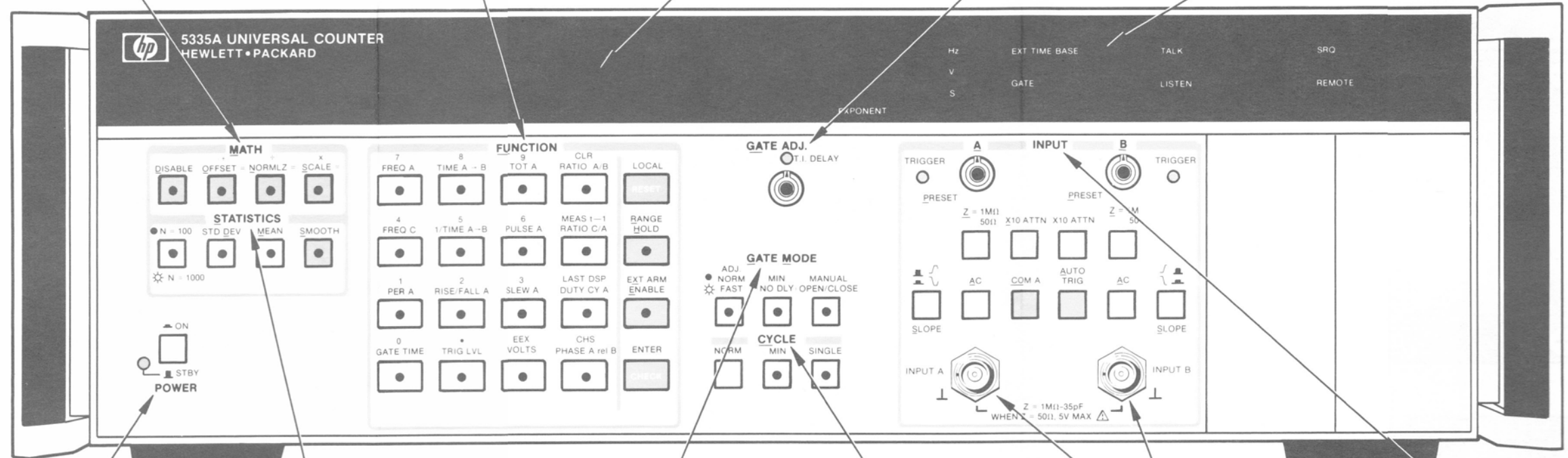

The POWER key applies power to the instrument when in the ON position (pressed in). In the STBY position (out), power is applied only to the high stability reference oscillator oven, Option 010.

The STATISTIC keys allow for the calculation of standard deviation or mean (average) of either 100 or 1000 measurement samples. The SMOOTH function performs a running average of ongoing measurements, and displays only the digits which are relatively stable.

The GATE MODE keys selects the ranges of gate time. NORM and FAST are adjustable (via GATE ADJ) modes, providing ranges of 20 ms to 4 s and 100 μs to 20 ms, respectively. MIN specifies the shortest possible gate time, dependent on the input signal. MANUAL opens and closes the gate with each successive press.

The CYCLE keys determine the length of time between measurement cycles. The NORM mode specifies about 250 ms wait time, the MIN mode rearms the measurement as soon as possible. The SINGLE mode manually starts one measurement.

The A and B Channel input BNC connectors.

The INPUT group keys and controls determine how the input signals are conditioned (with attenuation, impedance, slope, coupling, and common controls) and how the counter is triggered (AUTO TRIG or normal).

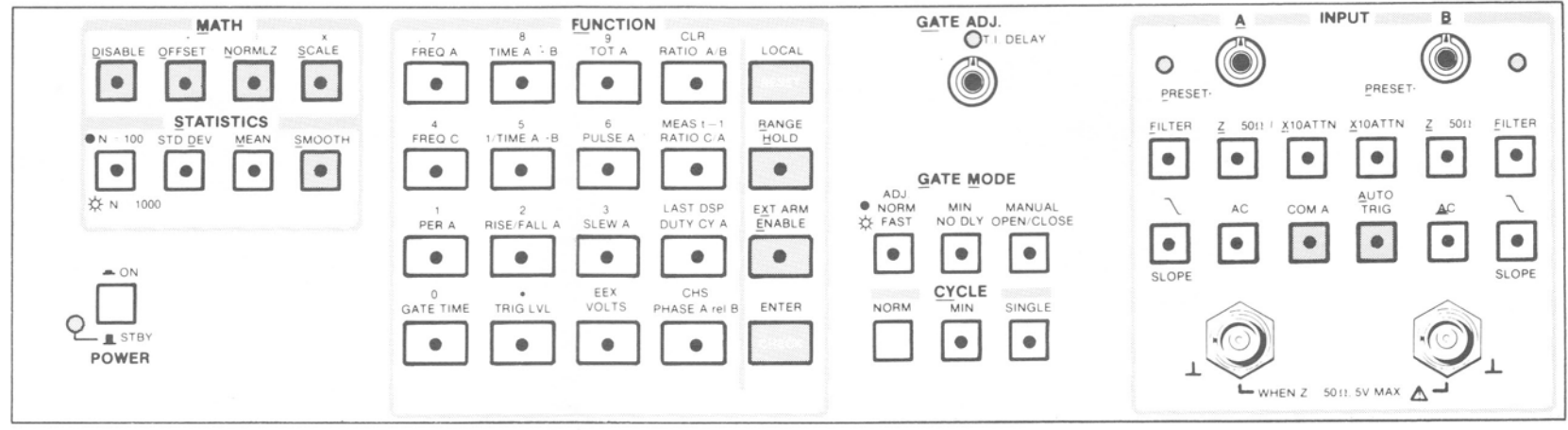

OPTION 030 CHANNEL C

The INPUT C module, Option 030, provides for FREQUENCY measurements from 150 MHz up to 1.3 GHz. Controls are provided for adjustable SENSITIVITY and PREAMP POWER.

The C Channel input BNC is a special fused connector. The fuse (HP Part No. 2110-0301) is 1/8A, and is accessible (for replacement) from the front panel.

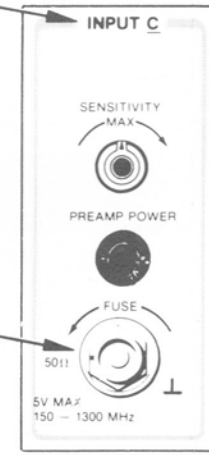

OPTION 020 DVM

The VOLTS module, Option 020, provides a fully floating auto-ranging DC voltmeter. Input DC voltage range up to 1000V.

The input connectors for the Option 020 Voltmeter. Input voltage 1000V DC max. COM is floating.

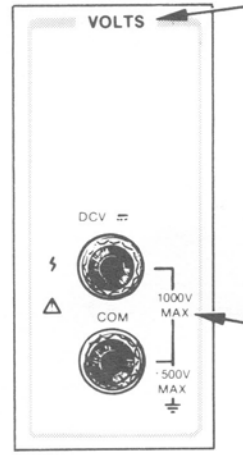

Figure 3-12. Front Panel Features

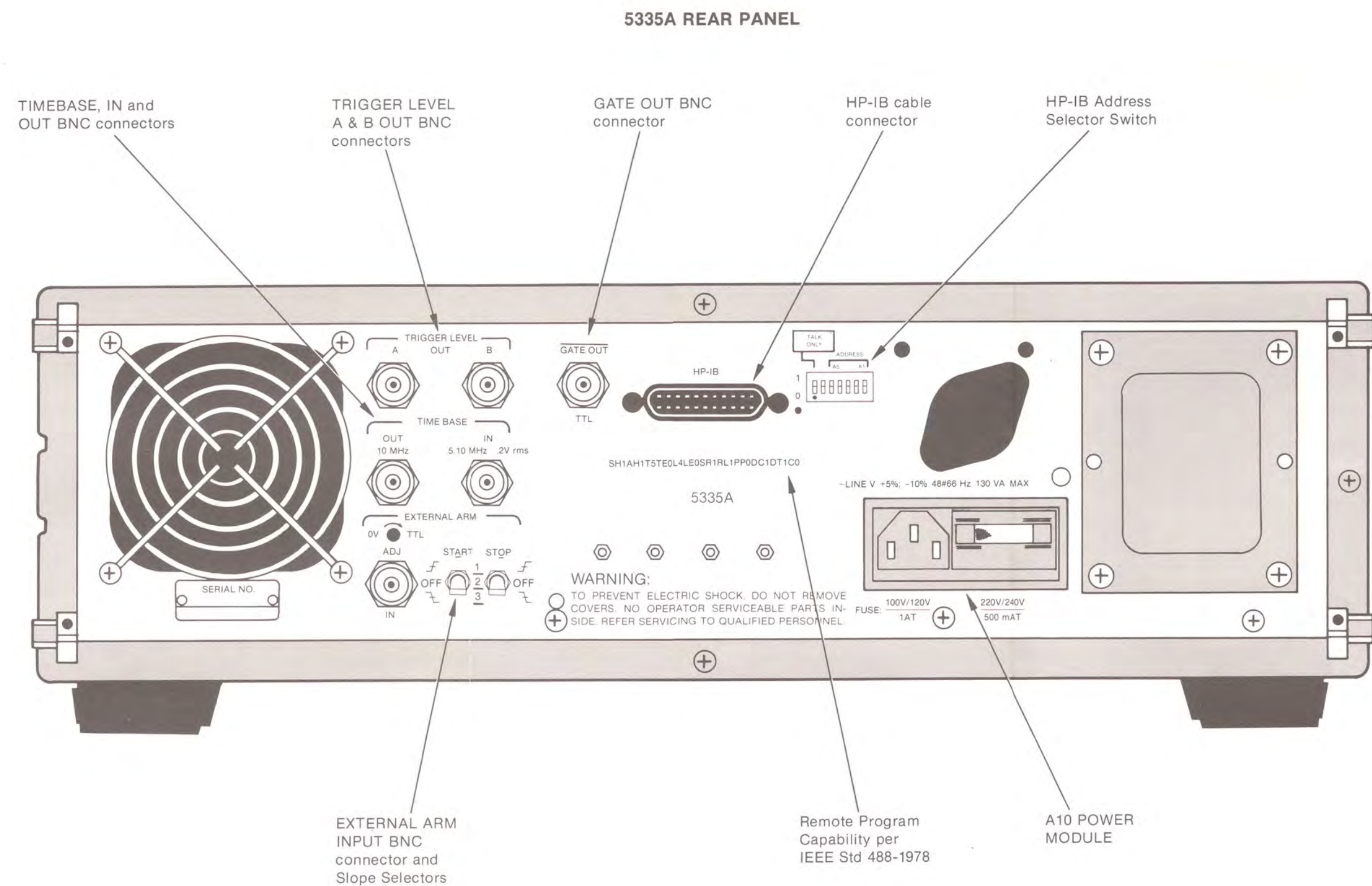

Figure 3-13. Rear Panel Features

3-100. REAR PANEL FEATURES

NOTE

Always press RESET after connecting or disconnecting a signal to the TIME BASE IN. Do not connect or disconnect a signal to the TIME BASE IN during measurements. FAIL 5.1 may be indicated, or the measurement may give a false reading. If FAIL 5.1 is indicated in this situation, pressing RESET clears the condition.

3-101. A number of signal inputs and outputs are provided on the rear panel. See Figure 3-13. TIME BASE OUT provides a 10 MHz signal that may be used as a reference for other instruments. If the reference to the HP 5335A is to be provided from another source, connect it to TIME BASE IN. This input accepts either 5 or 10 MHz signals and internally multiplies it up to 10 MHz. Whenever a reference is applied to the TIME BASE IN connector, the presence of that signal is sensed by internal circuitry, and the HP 5335A will automatically switch from the internal reference mode to the external reference mode of operation. This switch-over is indicated by the lighting of the OSC annunciator on the front panel display. If the reference is removed, the OSC annunciator will not automatically turn off. Pressing the RESET key will update the status of the reference OSC annunciator. Do not connect TIME BASE IN to OUT. No damage will occur but the reference frequency will be incorrect.

3-102. TRIGGER LEVEL OUT provides A and B Channel DC trigger levels for display on scopes. These signals are useful for a visual verification of proper triggering.

3-103. GATE OUT provides a logic low signal when the gate is open (see specifications). This can be used in many cases as a visual indication of when the measurement occurs, or the duration of the measurement.

3-104. The EXTERNAL ARM input can be used to specify the start and/or stop of a measurement. The various modes of arming are determined by the two, three-position switches. Refer to ARMING MODES Timing Diagram, Figure 3-14.

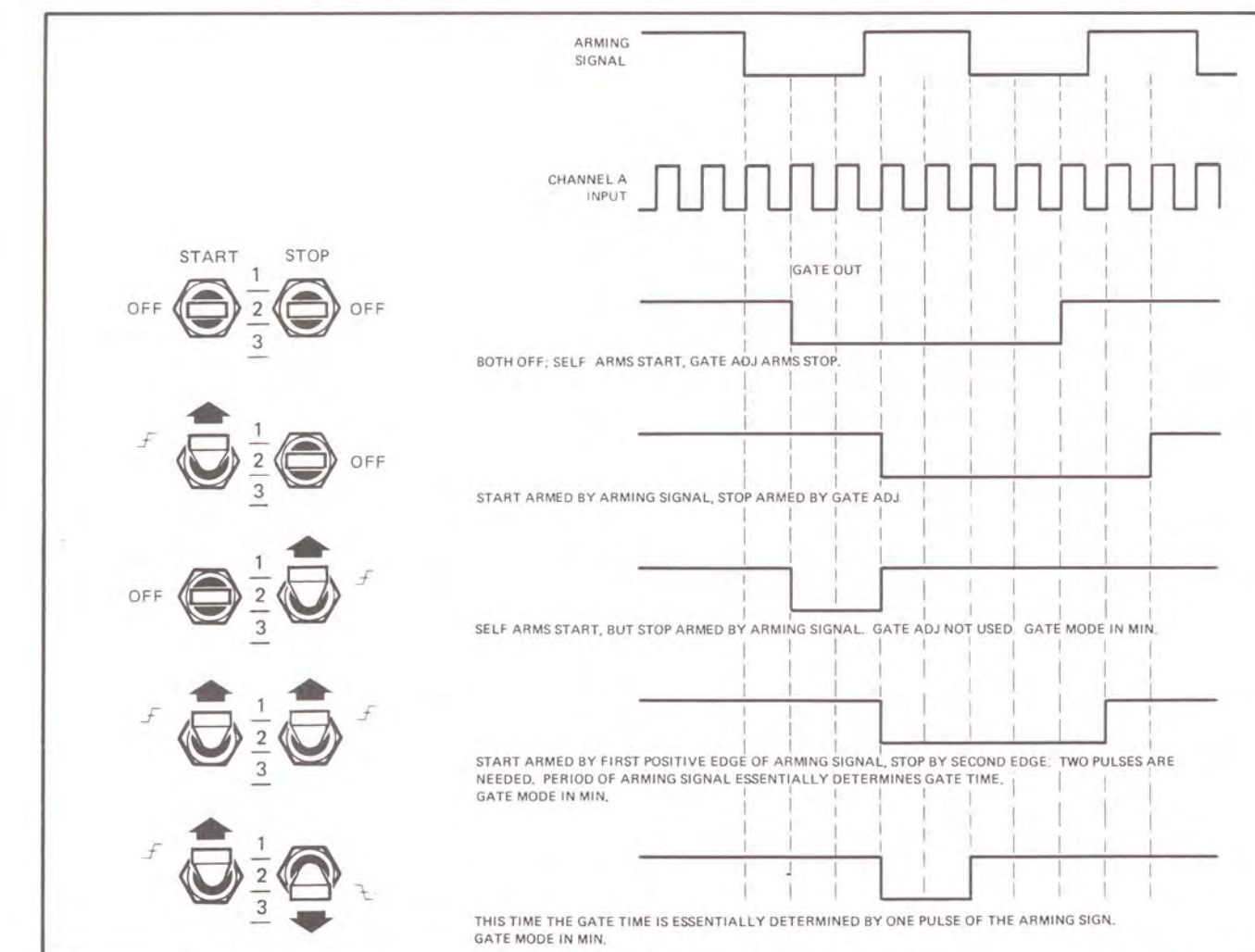

Figure 3-14. ARMING MODES Timing Diagram

Figure 3-12
FRONT PANEL FEATURES

(See Page 3-11)

OPEN FOLDOUT FOR FIGURE 3-13

NOTE

When STOP ARM is used the GATE MODE is usually used in MIN. To aid the user in this condition the 5335A will automatically set the GATE MODE to MIN when the STOP ARM is activated. However, the user can override this feature by simply selecting any other GATE MODE after setting up the ARMING modes.

3-105. When the GATE MODE is set to NORM, FAST, or MANUAL, and EXTERNAL ARM ENABLE is on, the "Gate Adj Timer" can be used to hold off the STOP ARM. Refer to Figure 3-15 for example.

Example:

- a. The rising edge of the ARMING signal enables the START of the gate and starts the Gate Adj Timer ①.
- b. The ARMING signal is then ignored until the Gate Adj timer times out ②.
- c. The next falling edge of the ARM signal ③ then arms the STOP.

In this way, multiples of the ARMING SIGNAL period can be used to arm the measurement.

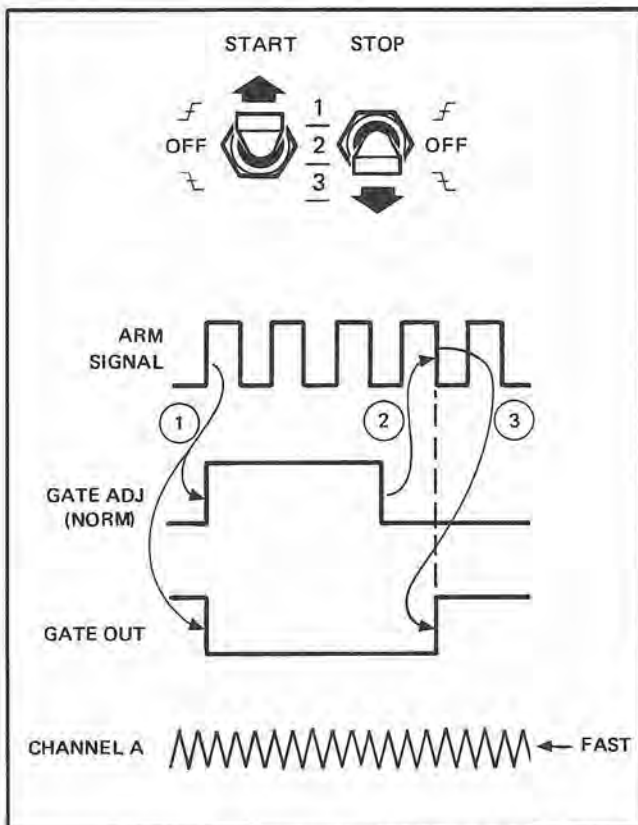

Figure 3-15. External Arming Signal Enable

3-106. DETAILED OPERATING INSTRUCTIONS

3-107. The following paragraphs provide detailed operating information. Within a specific function mode, (e.g., FREQ A, PER) a considerable amount of flexibility is present for both the type of input signal and measurement technique. The intent of the following paragraphs is to provide an instructional discussion, which demonstrates the *user control flexibility* for each major function mode. These operating guidelines should assist in making the most useful and accurate measurement possible.

3-108. FREQ A (Channel A Frequency)

3-109. The FREQ A mode makes measurements on frequencies up to 200 MHz through the Channel A INPUT. In this function the input is prescaled by two, however, there is no loss of resolution. On power-up, the 5335A assumes the FREQ A function with the GATE MODE in NORM. For a cw signal connected to INPUT A (and within the restrictions set by the input signal conditioning controls) the counter is self-arming, and measurements begin immediately. The displayed resolution is adjusted with the GATE ADJ control.

3-110. Suppose you need to measure a pulsed CW signal. Assuming no transients occur before the pulse, the frequency of this signal is measured by setting the GATE MODE to FAST, and adjusting for a gate time just under 200 μ s. The INPUT A controls are set to ac coupling, separate, with the trigger level control at PRESET. The counter is armed by the signal, and the gate opens automatically just after the start of the pulse. Figure 3-16 shows details of pulsed CW signal measurement.

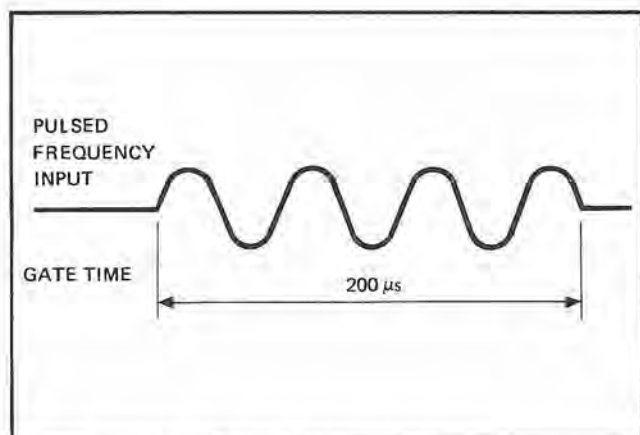

Figure 3-16. Pulsed CW Signal Measurement

3-111. To measure the frequency at various points along a chirp, use the 5335As arming capability. By setting the START ARM slope to positive and the STOP ARM slope to negative, and then turning EXT ARM ENABLE on, the frequency at various points can be measured. Use an external timing generator to produce the external arm signal. *Figure 3-17* shows details of chirp signal measurement.

3-112. If the timing generator cannot provide a pulse width of the appropriate width, the STOP ARM can be turned off, which lets the counter stop arm itself. With this setup, you can specify any gate time from 100 μ s on up. With GATE MODE in MIN, the counter will measure the frequency based on two periods of the input.

3-113. To measure the frequency of a pulse stream or pulse repetition frequency (prf), use the AUTO TRIG mode and dc coupling. AC coupling these types of signals tends to distort them slightly, due to the charging of the coupling capacitor. Additionally, the position of the signal on the zero preset trigger level is determined by the average dc level of the input. Depending on the pulse width and duty cycle, this dc average may be low enough to allow the base line noise to trigger the counter, producing extra counts. *Figure 3-18* shows AC coupling distortion of pulses.

3-114. DC coupling "fixes" the dc level of the input signal. Using AUTO TRIG in Preset or Adjustable allows the trigger level to be easily positioned at an optimum point. *Figure 3-19* shows advantage of DC coupling.

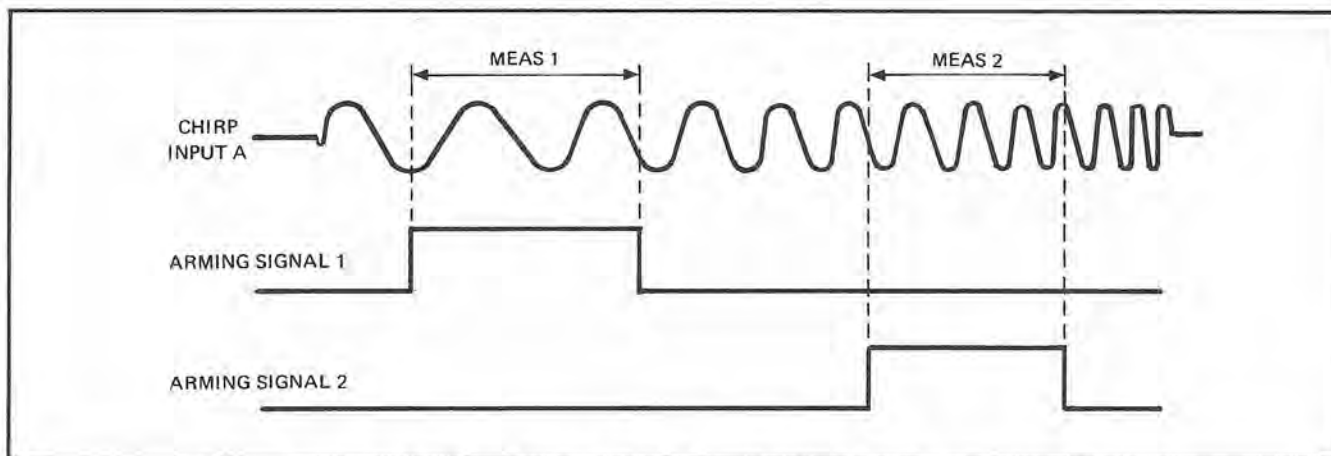

Figure 3-17. Varying Frequency Pulsed CW (Chirp) Signal Measurement

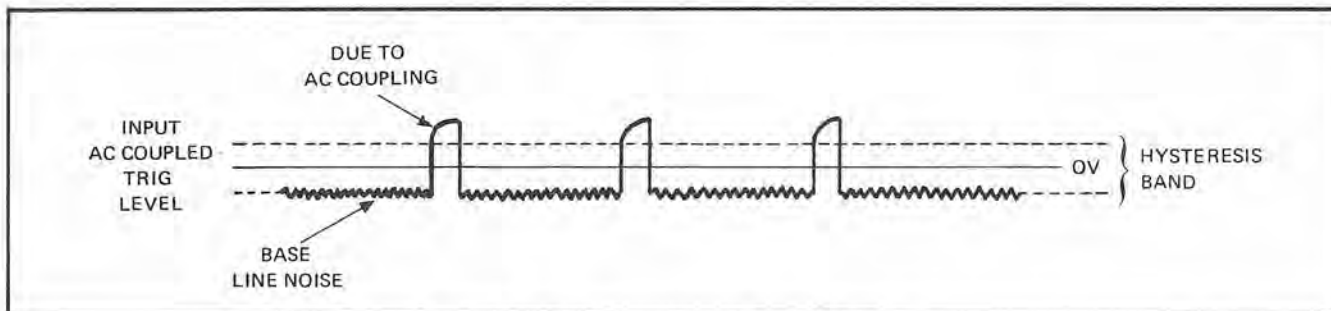

Figure 3-18. Pulse Distortion from AC Coupling

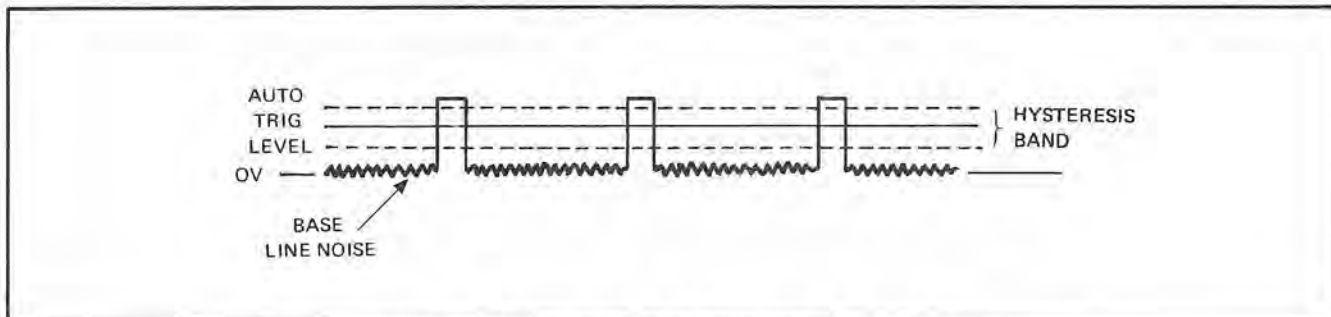

Figure 3-19. Advantage of DC Coupling for Pulse Signals

3-115. TIME A→B (Time Interval A to B)

3-116. The TIME A→B mode measures the time interval between a start signal at Channel A and a stop signal at Channel B. The START and STOP slopes, as well as trigger levels, are individually selectable. If the START and STOP signals are to be derived from a single signal, set the INPUT COM A (SEPARATE/COMMON) key to COM A (key in).

3-117. When TIME A→B is selected, the 5335A automatically shifts the GATE MODE from NORM to MIN (NO DELAY). If a "delay" (stop channel prevented from triggering for a specific period of time) is desired, the NORM, FAST, or MANUAL gate modes may be selected. When the delay is active, the red DELAY indicator will light.

3-118. For a simple time interval measurement with both slopes set to positive, the counter will display the time period illustrated. If the signals are not repetitive, be sure that AUTO TRIG is off. *Figure 3-20* shows time interval measurement relationships.

3-119. To measure a specific rise time manually, set both slopes to positive and set the INPUT SEPARATE/COMMON key to COM A. Setting the trigger levels to the desired points is simplified by using AUTO TRIG, however, the input signal to Channel A should be continuous. The selected trigger levels may be viewed by pressing the TRIG LVL key, or monitoring the rear panel trigger level outputs. For rise time measurements using the 10% and 90% points, see RISE TIME A. *Figure 3-21* shows voltage rise time measurement.

3-120. The T.I. DELAY (time interval delayed) mode is useful for making time interval measurements on signals, where false triggering (due to settling time, relay contact bounce, etc.) must be avoided. To insert a delay, set the GATE MODE to FAST (for a delay range of 100 μ s to 20 ms) or NORM (for a delay range of 20 ms to 4 s) and use the GATE ADJ control to select the required delay. *Figure 3-22* shows time interval delayed measurement.

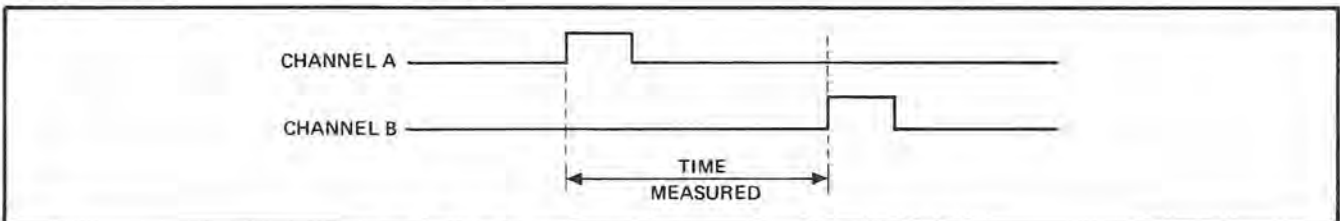

Figure 3-20. Time Interval Measurement Relationships

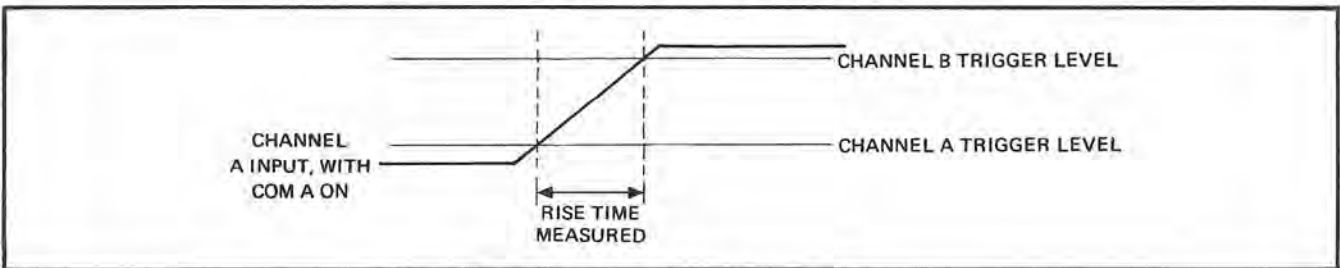

Figure 3-21. Rise Time Measurement

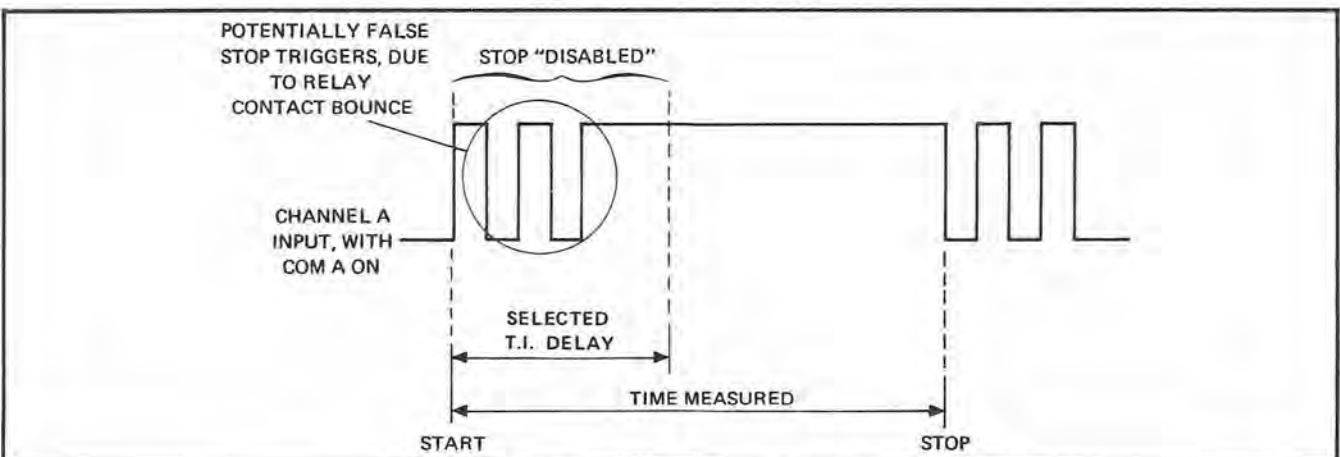

Figure 3-22. Delayed Time Interval Measurement

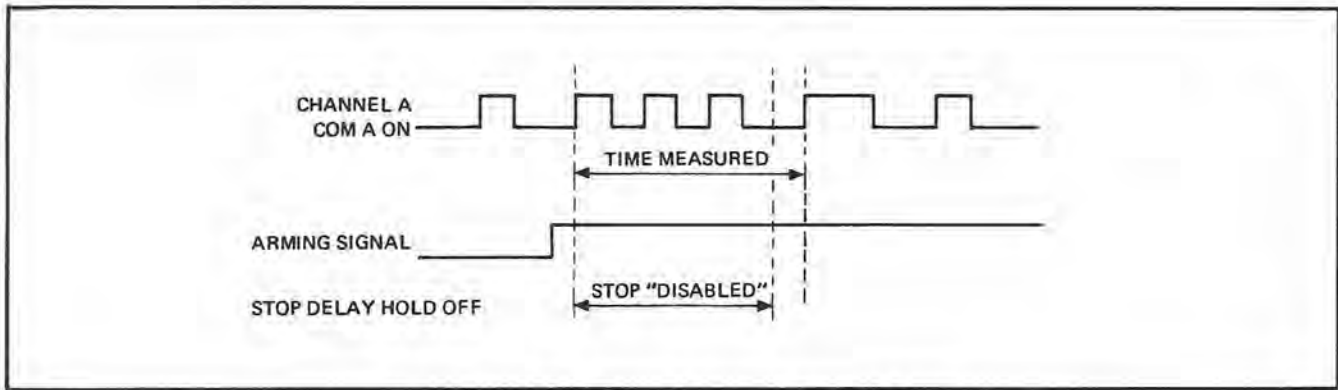

Figure 3-23. Time Interval Between Selected Pulses

3-121. To measure the time interval between two arbitrary pulses in a pulse train, use the counters external arming capability. Set the External Arm Start switch to select the starting pulse. Generate the arming signal from a timing generator. If the pulse width of the generator is programmable, you can also use this signal to specify the second pulse. If not, you may be able to use the stop hold-off delay feature described in the previous example. Figure 3-23 shows measurement of time interval between selected pulses.

3-122. TOT A (A Channel Events Totalized)

3-123. The TOT A mode will display the number of counts (events) received in Channel A. When TOT A is selected, the 5335A will automatically shift the GATE MODE from NORM to MANUAL, with the Gate initially closed. Pressing the MANUAL key opens the Gate and allows counts to accumulate. To stop counting, press the MANUAL key again. Pressing the MANUAL key once more allows counting to continue without resetting the previous total. To zero the count, press RESET. To begin a new measurement, close the gate and then press RESET. RESET is independent of the Gate.

NOTE

SMOOTH and MATH operations using "MEAS-1" will not operate in manual totalize.

3-124. In other gate modes TOT A behaves slightly differently. With GATE MODE set to NORM or FAST, the totalize acts somewhat like a frequency measurement. Based on the CYCLE and ARM modes, the totalizing will start and stop without the need for manual operation. Also, between measurements, the count will automatically reset itself.

3-125. To totalize the number of events in a burst of pulses which occur at one second intervals, set the GATE MODE to NORM. Adjust the GATE ADJ control

for a gate time of just under one-second (≈ 0.8 s). Set CYCLE to MIN. At a one second rate, the counter will update the display by the number of counts in each burst. The counter will reset and arm itself automatically for each cycle. Figure 3-24 shows counting a burst or group of pulses.

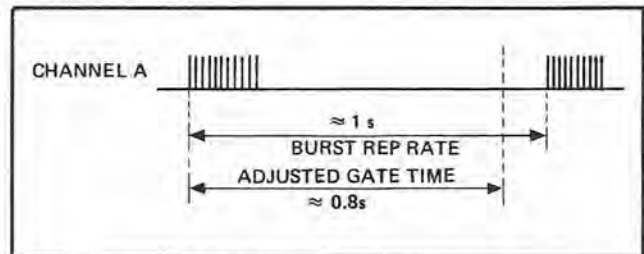

Figure 3-24. Counting Groups of Pulses

3-126. To totalize the number of events within a specified window, connect an externally generated arming signal to the rear panel ARM input. Set the START SLOPE switch to negative and the STOP to positive. Press EXT ARM ENABLE, and the counter will display the number of events within the window. If only the start point is specified by the ARMING signal, you may set the STOP SLOPE switch to OFF, and specify the stop point by putting the GATE MODE into FAST or NORM and setting the GATE ADJ control (as in paragraph 3-120). The SMOOTH and MATH operations can also be used for any totalize GATE MODE except MANUAL. Figure 3-25 shows counting groups of pulses in a specific time interval.

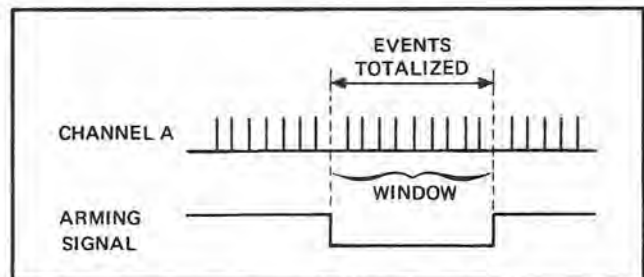

Figure 3-25. Specific Time Interval/Pulse Counting

3-127. Normally, the total is not sent to the HP-IB until the gate is closed. Some applications call for the total to be sent while the gate is still open and allowing counts. This is called totalize on the fly. To totalize on the fly put the counter in Totalize and set the GATE MODE to MANUAL and the CYCLE MODE to SINGLE. Start the count by pressing the MANUAL key. Data will then be sent on the fly during counting and once after the gate is closed. Data is sent only if two successive readings of the counting registers are equal, thus assuring an accurate reading. If the gate is reopened, data will once again be sent. The output data byte sent while the gate is open is *not* preceded by the Alpha Character "T", while the data sent after the gate is closed is. For further information on the data output format, refer to paragraph 3-211.

NOTE

Totalizing on the fly should be performed only on signals below 50 Hz.

3-128. RATIO A/B (Ratio of Frequencies of Channel A Signal to Channel B Signal)

3-129. The RATIO A/B mode allows the measuring of the ratio between two signal frequencies. The maximum frequency allowable to Channel A is 200 MHz, and to Channel B it is 100 MHz. The ratio is measured by connecting the original frequency into Channel B and the multiplied frequency into Channel A. The counter will display the multiplying factor "N". The number of digits of resolution is determined by the input frequencies and the Gate Time. *Figure 3-26* shows how to measure the ratio between two signal frequencies.

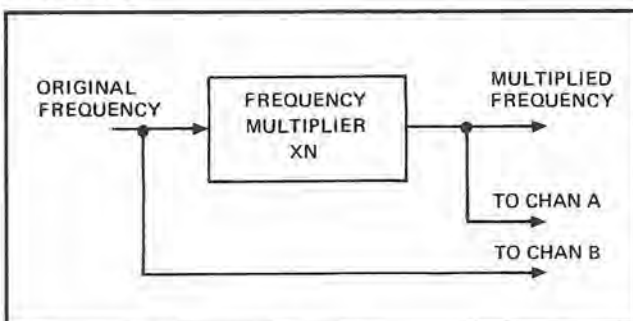

Figure 3-26. Frequency Ratio Measurement Connections

3-130. FREQ C

3-131. The FREQ C mode requires the optional C Channel Input Module. Input signals to INPUT C are prescaled by a-factor-of-20, however, as with FREQ A, there is no loss of resolution. When FREQ C is selected, the Channel A and B INPUT section is

disabled. Measurements through C Channel respond to all other controls the same as FREQ A measurement.

3-132. 1/TIME A→B

3-133. The 1/TIME A→B mode performs the standard TIME A→B measurement, mathematically computes the reciprocal value and displays it as units-per-second. This allows measurement configurations with a direct display of velocity. This mode can also utilize the stop channel delay holdoff (T.I. DELAY) feature, described for TIME A→B.

3-134. To determine the velocity of a moving object, connect the START electric eye to Channel A, and the STOP electric eye to Channel B. Select the 1/TIME A→B function. In this example the two electric eyes are 10 metres apart, so compensate by setting SCALE to 10. This will produce a measurement readout in metres per second. If the object takes 0.25 seconds to travel between the electric eyes, the answer displayed will be 40 (metres per second). If a 0 ns time is measured, a "0" result will be displayed. *Figure 3-27* shows how to measure velocity of moving objects.

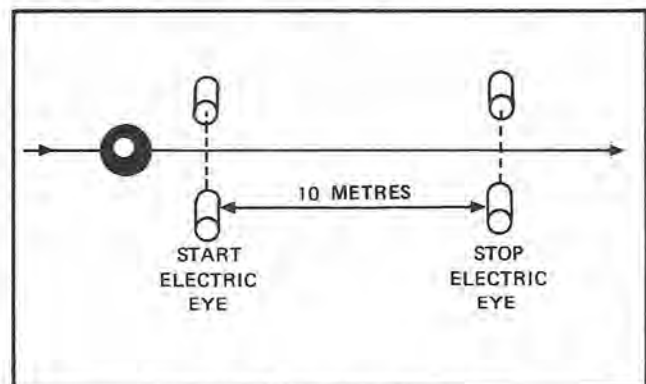

Figure 3-27. Velocity Measurement

3-135. PULSE A

3-136. The PULSE A mode measures the width of pulses input into Channel A. With the SLOPE A switch set to \uparrow , positive pulses will be measured. With the SLOPE A switch set to \downarrow , negative pulses will be measured. This mode can also utilize the stop channel delay holdoff (T.I. DELAY) feature, described for TIME A→B.

3-137. For continuous pulse streams, set the trigger level for AUTO PRESET. For single-shot pulses or special applications, use the manual modes of triggering. To locate and measure a selected pulse within a data stream use external arming. Set the START ARMING SLOPE to positive or negative, when measuring a

pulse on Channel A. Position the edge of the Arming Signal just ahead of the leading edge of the desired pulse and set EXT ARM ENABLE to on. Set the trigger level for AUTO PRESET (for most continuous signals) to automatically trigger at the 50% point. The GATE MODE will automatically switch to MIN and a single pulse measurement will be made. Figure 3-28 shows pulse with measurement.

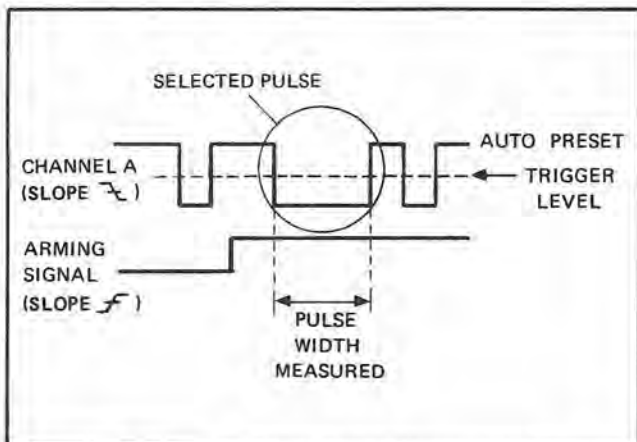

Figure 3-28. Pulse Width Measurement

NOTE

Pulse measurements are specified for trigger levels between the 40% and 60% points of the signal.

3-138. RATIO C/A

3-139. The RATIO C/A mode is similar to the RATIO A/B mode (paragraph 3-128), with the advantage of an extended frequency range for ratio measurements. The maximum frequency into Channel A is 200 MHz, and into C Channel it is 1300 MHz. Connect the higher of the two frequencies to the C Channel Input and select the RATIO C/A mode. The ratio will be displayed with the resolution being determined by the higher frequency and the selected Gate Time.

3-140. PER A (Channel A Period Measurement)

3-141. The PER A mode allows single period measurements or multiple period averages to be made on input signals into Channel A. In this mode, the input is not prescaled so the maximum frequency is 100 MHz. In NORM/FAST GATE MODES, a period average measurement is made where the number of periods averaged is determined by the setting of the GATE ADJ control and the period of the signal. For single period measurements, set the GATE MODE to MIN.

3-142. RISE/FALL A (Channel A Rise and Fall Time Measurement)

3-143. The RISE/FALL A mode automatically configures the counter to perform either rise or fall time measurements. The input is automatically set to COM A and triggering to AUTO TRIG. In this mode, AUTO TRIG automatically locates and sets the trigger levels at the 10% and 90% points of the input signal. Rise time measurements are made when the SLOPE A control is set to \nearrow . Fall time measurements are made when the SLOPE A control is set to \searrow . For rise and fall measurements, the input signal must be continuous. To measure the rise time on a selected slope of a signal, use external arming. Set the Start Arming Slope to positive and using an oscilloscope, position the leading edge just ahead of the selected slope of the signal. With SLOPE A positive, the counter will display the rise time; with SLOPE A to negative, the counter will display the fall time. Measurements are displayed in units of seconds. Figure 3-29 shows relationships in measurement of waveform rise and fall time measurement.

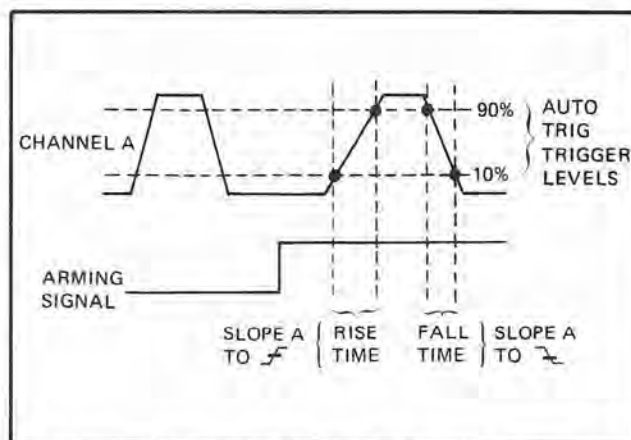

Figure 3-29. Waveform Rise and Fall Time Measurement

3-144. SLEW A

3-145. The SLEW A mode is similar to the RISE/FALL A mode, with the counter automatically selecting COM A and AUTO TRIG. However, to more easily accommodate analog signals, the measurement is displayed in units of Volts/seconds. Additionally, the MATH operations may also be selected to achieve a direct readout of the desired units. For example, programming the NORMLZ function with values of 10^3 or 10^6 will produce slew rates in units of volts/millisecond and volts/microsecond, respectively. As with RISE/FALL A, the measurements with SLEW A are with respect to the 10% and 90% points of the input

and the input must be continuous. Also, slew rates on selected slopes may be made, using the external arm method.

3-146. DUTY CYC A (Channel A Duty Cycle Measurement)

3-147. The DUTY CYC A mode measures and displays the proportional percentage of either the positive or negative durations of a given input digital waveform. The percentage of the positive pulse is given when the SLOPE A control is set to \mathcal{F} . The percentage of the negative pulse is given when the control set to \mathcal{E} . In this mode, the counter automatically sets the GATE MODE to MIN.

3-148. Duty cycle is actually measured indirectly through two measurements, Period and Pulse. Therefore, the signal should have a constant duty cycle in order to be accurately measured. If a particular place in a pulse stream needs to be examined in a changing duty cycle environment, be sure that the characteristics are repetitive.

3-149. To measure the positive duty cycle of a continuous asymmetrical waveform, select DUTY CYC A, set the SLOPE A control to \mathcal{F} and set triggering to Auto Preset. The counter will display a value, typically between 1 and 99 ("25" in this example) representing the duty cycle. No unit annunciators will light, as duty cycle is assumed as "percentage". Figure 3-30 shows waveform duty cycle measurement relationships.

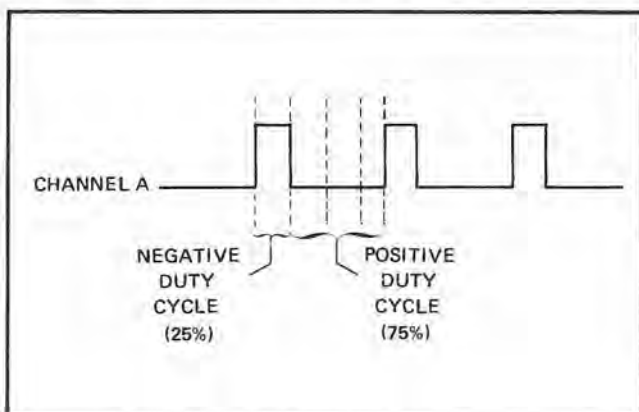

Figure 3-30. Duty Cycle Measurements

NOTE

Duty Cycle should be measured with the trigger level set between the 40% and 60% points of the signal peaks.

3-150. GATE TIME

3-151. The GATE TIME mode provides an indication of the duration of the gate time, displayed to three significant digits. When EXT ARM ENABLE is on, gate time resolution to 100 ns is displayed. The gate time is controlled (except in MIN) by the GATE ADJ control.

NOTE

As the gate is synchronized to the input signal, the actual gate time may be different from the displayed gate.

3-152. When in a TIME domain function mode (e.g., TIME A-B, PULSE A), the GATE TIME mode provides an indication of the amount of stop delay time selected. This time is set by the GATE ADJ control. When in a TIME domain function, with the GATE MODE in NORM or FAST, the T.I. DELAY indicator will be lighted.

3-153. Pressing GATE TIME does not affect the function set-up memory of the operating mode. Press the operating mode function key or RESET to resume measurements.

3-154. TRIG LVL (Trigger Level)

3-155. The TRIG LVL mode displays both the Channel A and B trigger levels. The display grouping on the left is Level A and the right is Level B. If the operating function mode, prior to the TRIG LVL, was RISE/FALL or SLEW, the levels displayed will be the 10% and 90% points of the input signal. For PHASE A rel B, the levels will be the 50% points. Pressing TRIG LVL does not affect the function set-up memory of the operating mode. Press the operating mode function key or RESET to resume measurements.

3-156. When outputting the Channel A and B Trigger Levels, via the HP-IB, two complete numbers are sent, prefixed with the letters A and B.

3-157. VOLTS

3-158. The VOLTS mode requires the option 020 DVM input module. The DVM is fully floating and autoranging. A unique feature is that there is no need for predetermined gate times. This means that, like frequency, you may set gate time to most any setting desired. Also, this means that you can arm both the start and the stop of a voltage measurement.

3-159. To measure the voltage of a signal at a specified point, use external arming. Set the start arm

switch to positive and the stop arm switch to negative. Position the arming signal to allow for the step response time of the voltmeter (t_1). For environments with 50 or 60 Hz noise problems, gate times which are multiples of 100 ms will reduce error in the measurements. *Figure 3-31* shows the time relationship of the voltage measurement.

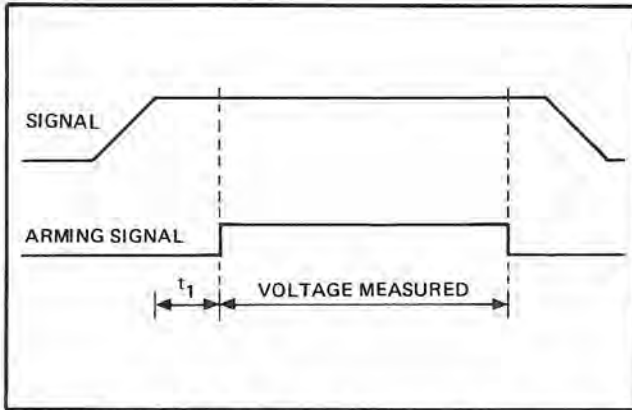

Figure 3-31. Voltage Measurement Time

- PHASE A rel B measurements should be made with the SEP/COM switch in SEP. If COM A is momentarily selected, the RESET key should be pressed.
- RESET should be pressed after any change to the INPUT controls, particularly for SLOPE and SEP/COM controls.

NOTE

Because phase requires a steady signal input, the use of statistics is not valid (i.e., the STD DEV of a steady signal should be 0, and the MEAN should be the same as any one measurement). Therefore, the use of STATISTICS for PHASE measurements is not recommended.

3-160. PHASE A rel B

3-161. The PHASE mode measures the phase of the signal on Input A, relative to the signal on Input B. The phase difference is displayed in degrees. In this mode, Auto Preset triggering is automatically selected. The trigger points are set to the 50% points of each signal, regardless of either signals offset.

3-162. The overall display range is -180° to $+360^\circ$. The display of a PHASE measurement is configured such that around 0° , the operating range is -180° to $+180^\circ$, but around $+180^\circ$ the operating range is 0° to 360° . If RANGE HOLD is on, the range is fixed to 0° to 360° . The PHASE mode cannot be externally armed. *Figure 3-32* shows waveform phase relationships.

3-163. Phase measurements are made through a series of individual measurements, therefore certain input and operational restrictions apply:

- The frequency and phase angle of the signals should be constant.
- Frequencies can be measured up to 1 MHz.

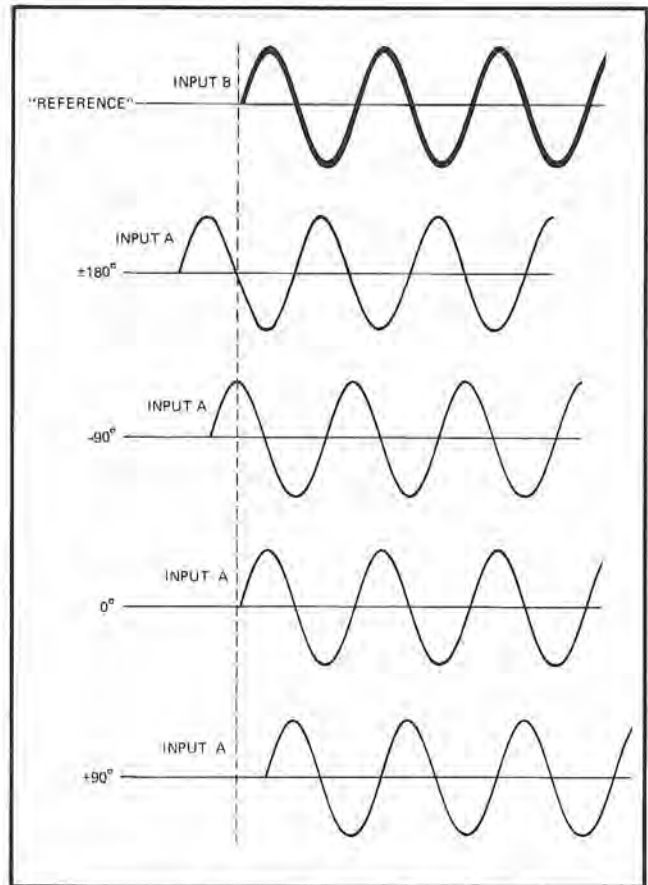

Figure 3-32. Waveform Phase Relationships

Table 3-2. Function Key Reference Summary

| FUNCTION KEY | UNITS | TRIG MODE | SLOPE A USAGE | ARMING | GATE ADJ | COMMENTS |
|---------------|-------|-----------------------|--|------------------|--------------------------|---|
| FREQ A | Hz | Any | | Yes | Gate | Prescaled-by-2 |
| TIME A→B | s | Any | | Yes | Stop Delay | |
| TOT A | — | Any | | If not in manual | Gate | Smooth and MEAS _{t-1} will not operate when in MANUAL |
| RATIO A/B | — | Any | | Yes | Gate | |
| FREQ C | Hz | N.A. | N.A. | Yes | Gate | Prescaled-by-20 |
| 1/TIME A→B | 1/s | Any | | Yes | Stop Delay | |
| PULSE A | s | Any | f = Positive Pulse \bar{f} = Negative Pulse | Yes | Stop Delay | |
| RATIO C/A | — | Any | | Yes | Gate | "A" prescaled-by-2, "C" prescaled-by-20 |
| PER A | s | Any | | Yes | Gate | |
| RISE/FALL A | s | 10%, 90% | f = Rise Time \bar{f} = Fall Time | Yes | MIN only | Signal should be >50 Hz and <25 MHz. |
| SLEW A | V/s | 10%, 90% | f = Rising Slope \bar{f} = Falling Slope | Yes | MIN only | Signal should be >50 Hz and <25 MHz. |
| DUTY CYC A | s | Any | f = % High \bar{f} = % Low | No | MIN only | Needs constant signal |
| GATE TIME | s | N.A. | | Yes | Shows Gate or Stop Delay | Will not affect function memory |
| TRIG LVL | V | Follows Last function | N.A. | N.A. | N.A. | Will not affect Function memory, sends 2 numbers on HP-IB |
| VOLTS | V | N.A. | N.A. | Yes | Gate | |
| PHASE A rel B | ° | 50% | | No arming | MIN only | Needs constant signal. Range 0° to 360° if RANGE HOLD on >30 Hz |

3-164. SPECIAL FUNCTIONS

3-165. Functions 17, 18, 19, and 20 are additional functions that are available in the 5335A.

- 17 FREQ B
- 18 TIME B→A
- 19 TOT A→B
- 20 PULSE B

These functions are accessed via the HP-IB through the normal FN or FU command, however, they may also be accessed manually through the keyboard. This is an example of invoking FREQ B, function 17:

Press: SCALE, SMOOTH, 1, 7, ENTER

3-166. After pressing SMOOTH the display will show the word "SPECIAL". After pressing ENTER the

counter will be in FREQ B. No function lamp indication is given for these special functions.

- When using TOTALIZE A→B output is given only after the gate is closed. To start the totalizing, a pulse from B must first be received. Closing the gate is also synchronized with a pulse from Channel B.
- Diagnostics are programmed by sending FN99, followed by a diagnostic code that is programmed into the SCALE register. For example, FN99 MS12, calls up diagnostic 12. (See Section VIII). Via the keyboard the diagnostics are called similarly. Press SCALE, SMOOTH, 9, 9, ENTER, then SCALE, 1, 2, ENTER.

3-167. PROGRAMMING

3-168. Introduction

3-169. The 5335A Universal Counter is fully compatible with the Hewlett-Packard Interface bus (HP-IB). The bus capability is installed as standard equipment and allows the counter to respond to remote control instructions and output measurement results via the HP-IB. At the simplest level, the 5335A can output data to other devices such as the 5150A Thermal Printer or the 59303A Digital-to-Analog Converter. In more sophisticated systems, a computing controller or other controllers can remotely program the 5335A to perform a specific type of measurement, trigger the measurement, and read the results.

NOTE

HP-IB is Hewlett-Packard's implementation of IEEE Std. 488-1978, "Standard Digital Interface for Programmable Instrumentation."

3-170. This section describes how to use the 5335A on the HP-IB. Before programming, the operator must be familiar with the selected computing controller (e.g., the 9825A, 9830A, or 9835/85A calculators), the capabilities of the HP-IB, and the manual operation and capabilities of the 5335A. The following HP manuals provide useful background information:

- HP-IB User Guide, 9830A (P/N 59300-90002)
- Hewlett-Packard 9825A Calculator General I/O Programming (P/N 09825-90024)
- Hewlett-Packard 9825A Calculator Extended I/O Programming (P/N 09825-90025)
- Condensed Description of the Hewlett-Packard Interface Bus (P/N 59401-90030)
- Abbreviated Description of Hewlett-Packard Interface Bus (P/N 5955-2903)
- HP-IB Quick Reference (P/N 5955-2902)

3-171. Interface Function

3-172. The capability of a device connected to the bus is specified by its interface functions. *Table 3-3* lists the 5335A Interface Functions using the terminology of the IEEE 488-1978 standard. These features are also listed below the rear panel HP-IB connector, as follows:

SH1, AH1, T1, TE0, L2, LE0, SR1, RL1, PP0, DC1, DT1, C0

Table 3-3. HP-IB Interface Capability

| INTERFACE FUNCTION SUBSET IDENTIFIER | INTERFACE FUNCTION DESCRIPTION |
|--------------------------------------|--|
| SH1 | Complete source handshake capability. |
| AH1 | Complete acceptor handshake capability. |
| T5 | Talker (basic talker, serial poll, talk only mode) |
| TE0 | No extended talker capability. |
| L4 | Listener (basic listener, no listen only mode, does not unaddress to listen if addressed to talk). |
| LE0 | No extended listener capability. |
| SR1 | Service request capability. |
| RL1 | Complete remote/local capability. |
| PP0 | No parallel poll capability. |
| DC1 | Device clear capability. |
| DT1 | Device trigger capability. |
| C0 | No controller capability. |

3-173. The number following the interface function code indicates the particular capability of that function as listed in Appendix C of IEEE Std. 488-1978. Interface functions provide the means for a device to receive, process, and send messages over the bus.

3-174. Nearly all controls on the 5335A can be programmed remotely, and data from measurements can be sent to other devices through the HP-IB. The TALK, LISTEN, SRQ, and REMOTE annunciators in the display indicate the state of the instrument. The following paragraphs describe the basic programming capability of the 5335A Universal Counter.

TALK:

When addressed as a Talker, whether by a controller or by the TALK ONLY switch, the 5335A will try to send data out to other devices on the bus. Normally this data is the measurement data.

LISTEN:

When addressed as a Listener, the instrument can accept any number of commands from a controller on the bus. These commands will usually be used to program the instrument's operation.

SERVICE REQUEST:

SRQ can be sent out to the bus at the end of measurements and on error or failure messages. Normally SRQ is inhibited, but certain commands will enable this feature. See "WA" (WAIT) and "SR" (SERVICE REQUEST).

REMOTE/LOCAL:

Normally the 5335A is under local control. In order to program the instrument it must be in Remote. Once in Remote, all programmable controls are in remote and cannot be affected by manual command. The RESET key may be used to manually return to local control when Local Lockout is OFF. If Local Lockout is ON, the RESET key is ignored.

PARALLEL POLL:

No parallel poll capability in the 5335A.

DEVICE CLEAR:

When a universal or selected device clear is received, the instrument clears out all input buffers

and resets the hardware for a new measurement. The display will flash momentarily. SRQ is also cleared. Device clear can be used to clear an ERROR message.

DEVICE TRIGGER:

When a device trigger is received, a new measurement is started.

CONTROLLER:

No controller capability in the 5335A.

3-175. Bus Messages

3-176. Messages are the means by which devices exchange control and measurement information. There are 12 basic messages which can be sent over the interface. *Table 3-4* lists each bus message, a description of the message, how the 5335A uses that message, and examples of the various controller's implementation of the messages.

Table 3-4. 5335A Bus Message Usage

| Message | Description | 5335A Use | Sample 9825 Statements (5335A Set to Address 03) | Sample 9835/45 Statements (5335A Set to Address 03) |
|-------------------------|--|---|--|--|
| Data | Transfers device-dependent information from one device to one or more devices on the bus. | Sends measurement data. See paragraph 3-211 for output format. Accepts program codes See Table 3-6 for code set. | red 703, A wrt 703, "FN9" | ENTER 703, A OUTPUT 703, "FN9" |
| Trigger | Causes a group of selected devices to simultaneously initiate a set of device-dependent actions. | Starts a new measurement. | trg 7 or trg 703 | TRIGGER 7 or TRIGGER 703 |
| Clear | Causes an instrument to be set to a predefined state (a certain range, function, etc.). | Sames as front panel RESET. Clears internal count and starts new measurement. Clears any Error condition. | clr 7 or clr 703 | CLEAR 7 or CLEAR 703 |
| Remote | Permits selected devices to be set to remote operation, allowing parameters and device characteristics to be controlled by Bus Messages. | Causes counter to go to remote operation if REN is true and counter is addressed to listen. In absence of program data, remote operation is according to state of front panel settings just prior to going to remote. Locks out all push-buttons except Local | rem 7 or rem 703 | REMOTE 7 or REMOTE 703 |
| Local | Causes selected devices to return to local (front panel) operation. | Goes to local front panel control. In absence of front panel data, local operation is according to the state of the remote data just prior to going to local. The following states are invoked; WA0, DR0, and SR0. | lcl 703 | LOCAL 703 |
| Local Lockout | Disables local (front panel) controls fo selected devices. | Disables front panel RESET. 5335A remains in remote. | llo 7 | LOCAL LOCKOUT 7 or LOCAL LOCKOUT 703 |
| Clear Lockout and Local | Returns all devices to local (front panel) control and simultaneously clears the Local Lockout Message. | Local Lockout cleared and returns to local front panel control. | lcl 7 | LOCAL 7 |
| Require Service | Indicates a device's need for interaction with the controller. | Used to flag an error or fail condition or indicate one of several instrument specific messages coded in status byte. | rds(703)—A if bit (7, A) (bit 7=1 if SRQ true) | STATUS 703; A |
| Status Byte | Presents status information of a particular device; one bit indicates whether or not the device currently requires service, the other 7 bits (optional) are used to indicate the type of service required. | Bit 7 is set if service is requested. Additionally, Bit 1, 2, 3, 4, 6, 7, or 8 may be set, indicating a specific instrument condition or status, see Table 3-7. | | STATUS 703; A FOR I=7 TO 0 STEP - 1 PRINT I: BIT (A, I) NEXT I END (sample program prints status of Bits 1 through 8) |
| Status Bit | A single bit of device dependent status information which may be logically combined with status bit information from other devices by the controller. | Does not use | — | — |
| Pass Control | Passes bus controller responsibilities from the current controller to a device whic can assume the Bus supervisory role. | Does not use | — | — |
| Abort | Unconditionally terminates Bus communications and returns control to the system controller. | Clears Talk, Listen, Serial Poll Enable registers on 5335A HP-IB Interface. Front panel set-up does not change. | cli 7 | ABORTIO 7 |

3-177. Address Selection

3-178. To use the 5335A in an HP-IB system, first set the rear panel address switches as shown in *Table 3-5*. The leftmost switch sets the counter to the ADDRESSABLE mode or the TALK ONLY mode. ADDRESSABLE mode is used whenever a calculator or other controller is used with the system. TALK ONLY mode is used when the counter is operating under its own control (no controller on bus) and outputs its measured result to another device on the bus, such as a printer.

3-179. The five righthand switches, A₅ through A₁, set the talk and listen addresses of the 5335A when it is

used in the ADDRESSABLE mode. *Table 3-5* shows the possible address settings and the corresponding ASCII codes for talk and listen.

3-180. The examples listed in this section assume an address setting of 00011, which is a 5-bit binary code for the decimal number three. This number is important when using an HP 9825A, 9835A, or 9845A calculator, since the calculator addresses the 5335A to talk and listen by using the code 703. (The "03" being the 5335A address.) The ASCII characters for this same switch setting are "C" for a talk address and "#" for a listen address. These characters are used when the computing controller is an HP 9830A calculator.

Table 3-5. HP-IB Address Switch Selections

| ASCII CODE CHARACTER | | ADDRESS SWITCHES | | | | | DECIMAL EQUIVALENT OF BINARY SWITCH SETTING |
|----------------------|------|------------------|----------------|----------------|----------------|----------------|---|
| LISTEN | TALK | A ₅ | A ₄ | A ₃ | A ₂ | A ₁ | |
| SP | @ | 0 | 0 | 0 | 0 | 0 | 00 |
| ! | A | 0 | 0 | 0 | 0 | 1 | 01 |
| " | B | 0 | 0 | 0 | 1 | 0 | 02 |
| # | C | 0 | 0 | 0 | 1 | 1 | 03 |
| \$ | D | 0 | 0 | 1 | 0 | 0 | 04 |
| % | E | 0 | 0 | 1 | 0 | 1 | 05 |
| & | F | 0 | 0 | 1 | 1 | 0 | 06 |
| ' | G | 0 | 0 | 1 | 1 | 1 | 07 |
| (| H | 0 | 1 | 0 | 0 | 0 | 08 |
|) | I | 0 | 1 | 0 | 0 | 1 | 09 |
| * | J | 0 | 1 | 0 | 1 | 0 | 10 |
| + | K | 0 | 1 | 0 | 1 | 1 | 11 |
| , | L | 0 | 1 | 1 | 0 | 0 | 12 |
| — | M | 0 | 1 | 1 | 0 | 1 | 13 |
| . | N | 0 | 1 | 1 | 1 | 0 | 14 |
| / | O | 0 | 1 | 1 | 1 | 1 | 15 |
| Ø | P | 1 | 0 | 0 | 0 | 0 | 16 |
| 1 | Q | 1 | 0 | 0 | 0 | 1 | 17 |
| 2 | R | 1 | 0 | 0 | 1 | 0 | 18 |
| 3 | S | 1 | 0 | 0 | 1 | 1 | 19 |
| 4 | T | 1 | 0 | 1 | 0 | 0 | 20 |
| 5 | U | 1 | 0 | 1 | 0 | 1 | 21 |
| 6 | V | 1 | 0 | 1 | 1 | 0 | 22 |
| 7 | W | 1 | 0 | 1 | 1 | 1 | 23 |
| 8 | X | 1 | 1 | 0 | 0 | 0 | 24 |
| 9 | Y | 1 | 1 | 0 | 0 | 1 | 25 |
| : | Z | 1 | 1 | 0 | 1 | 0 | 26 |
| ; | [| 1 | 1 | 0 | 1 | 1 | 27 |
| < | \ | 1 | 1 | 1 | 0 | 0 | 28 |
| = |] | 1 | 1 | 1 | 0 | 1 | 29 |
| > | ~ | 1 | 1 | 1 | 1 | 0 | 30 |

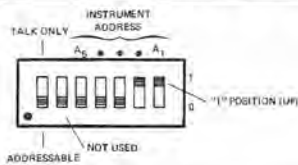
**NOTE**

THE TALK ONLY SWITCH SHOULD BE CHANGED ONLY WHEN THE INSTRUMENT IS OFF.

3-181. Device Command Definitions

3-182. A device command is a sequence of two or more ASCII-coded bytes, sent to the 5335A over the

HP-IB, that causes the counter to perform a specific function. Before discussing individual device commands, it is useful to classify these commands into five types:

1. **Numeric Command:** *Type N;* A sequence of two ASCII-coded bytes followed by a sequence of bytes representing a decimal number and a terminator. A terminator is either a comma, semicolon, space, carriage return, or line feed. A Termination may also be implied with the start of the next command. For a numeric command, the entry must follow the following format:

<N spaces> [sign] <J digits> [.<K digits>] [E [Sign] <L digits>]

where:

N=0 to any value
J=1 to 12
K=0 to 11
L=1 or 2

and:

J+K ≤ 12
Absolute value of number < 10¹⁰. If more than 12 digits are received, they are ignored.

The following commands are equivalent:

| 9825A | HP 85A |
|------------------------------|--------------------------------|
| wrt 703, "RE, MS 123456" | OUTPUT 703; "RE, MS 123456" |
| wrt 703, ;"REMS+1.23456E+05" | OUTPUT 7,3; "REMS+1.23456E+05" |
| wrt 703, "RE, MS123.456E3" | OUTPUT 703; "RE, MS123.456E3" |
| 123456→A; wrt 703 "RE MS", A | S = 123456 |
| wrt 703, "RE, MS123.456E3" | OUTPUT 703; "RE MS", Scale |
| | OUTPUT 703; "RE, MS123.456E3" |

2. **Binary Command:** *Type B;* A sequence of two ASCII-coded bytes followed by either a 0 or a 1. The 0 indicates the selected function if "OFF" or "FALSE", and the 1 (or any non-zero value) indicates "ON" or "TRUE". The binary command uses the same format as numeric commands. The following are binary commands:

| | | |
|-----------------------|-------|------------------------|
| wrt 703, "WA1" | TRUE | OUTPUT 703; "WA1" |
| wrt 703, "WA0" | FALSE | OUTPUT 7,3; "WA0" |
| wrt 703, "WA123" | TRUE | OUTPUT 703; "WA123" |
| | | T = 1 |
| 1→A; wrt 703, "WA", A | TRUE | OUTPUT 703; "WA", True |

3. **Integer Commands:** *Type I;* A sequence of two ASCII-coded bytes followed by a sequence of bytes representing a decimal number and a terminator. For integer commands, negative numbers are converted to their absolute values. If the number is outside the expected range, the parameter is converted to zero. The integer command uses the same format as numeric commands. The following commands are equivalent:

| 9825A | HP 85A |
|----------------------|------------------------|
| wrt 703, "CY2" | OUTPUT 703; "CY2" |
| wrt 703, "CY-2" | OUTPUT 703; "CY-2" |
| wrt 703, "CY 0.2E+1" | OUTPUT 703; "CY0.2E+1" |

4. **Terse Commands:** *Type T*; A sequence of two ASCII-coded bytes not followed by a numeric or binary number. Requests a specific function or subroutine to be executed. For example, the characters "IN" will cause the counter to **IN**itialize all control settings to default status.
5. **Special Commands:** *Type **; A sequence of two ASCII-coded bytes followed by a sequence of bytes representing some defined value. For example, the characters "MOD" will program the **Math Off**set to the value of the last **Display**.

3-183. PROGRAMMING 5335A OPTION 040

3-184. Option 040 enables signal conditioning controls, including trigger levels to be programmed remotely, via HP-IB. Programming is accomplished by addressing the counter as a listener and sending it the desired device commands. *Table 3-6* shows the device commands for the Option 040 Programmable Input Amplifiers. The first section contains the standard device commands which remain unchanged, and the second section lists the added commands with Option 040.

3-185. Trigger Level Setting TR, AT, BT

3-186. The trigger levels may be set with a resolution of 10 mV over the ± 5 volt range. The TR1 command may come at any time to put the trigger levels into remote. AT and BT precede the programmed levels. An ERROR 1.1 will be displayed if a trigger level

outside the specified rate (-5 to +5 volts) is programmed. The IN (Initialize) command does not affect the programmed trigger level values set by AT and BT.

NOTE

It is necessary to send the TR0 (TRIG REMOTE) command prior to an AU1 (AUTO TRIGGER) or AP1/BP1 (PRE-SET) command.

3-187. The 5335A DEVICE COMMANDS

3-188. Almost every control on the 5335A can be programmed via the HP-IB. Programming is accomplished by addressing the counter as a listener and sending it device commands. *Table 3-6* shows the complete set of device commands. The commands are organized into functional groups for ease of description and use.

Table 3-6. 5335A Device Commands

| Command Group | Equivalent Key/Control | Description | Command Type | Device Command | |
|--|------------------------|--|--|-----------------------------------|-------------------|
| NOTE | | | | | |
| Bold print indicates the conditions set on power-up or initialization of the counter. Some of the Key/Controls are disabled or set to "off", as indicated in the Description column. | | | | | |
| MATH | DISABLE | Disable Math group Enable Math group | B B | MD0 MD1 | |
| | OFFSET | Set OFFSET off Set OFFSET value Set OFFSET to last disp. Set OFFSET to MEAS _{t-1} | N N * * | MO0 MO<#> MOD MOM | |
| | NORMLZ | Set NORMLZ off Set NORMLZ value Set NORMLZ to LAST Disp. Set NORMLZ to MEAS _{t-1} | N N * * | MN0 MN<#> MND MNM | |
| | SCALE | Set SCALE off Set SCALE value Set SCALE to LAST Disp. Set SCALE to MEAS _{t-1} | N N * * | MS0 MS<#> MSD MSM | |
| | STATISTIC | N=100/1K | Set N=100 Set N=1000 | B B | SN0 SN1 |
| | | STD DEV | Disable Standard Deviation Enable Standard Deviation | B B | SD0 SD1 |
| | | MEAN | Disable Mean Enable Mean | B B | SM0 SM1 |
| | | SMOOTH | Disable Smooth Enable Smooth | B B | SS0 SS1 |
| | | SPECIAL OUTPUT | Special Output disable Special Output enable | B B | SO0 SO1 |
| | FUNCTION | ALL FUNCT. | Select Function | I I | FU<#> FN<#> |
| FREQ A | | Standard Functions | | FN1 | |
| TIME A→B | | | FN2 | | |
| TOT A | | | FN3 | | |
| RATIO A/B | | | FN4 | | |
| FREQ C | | | FN5 | | |
| 1/TIME A→B | | | FN6 | | |
| PULSE A | | | FN7 | | |
| RATIO C/A | | | FN8 | | |
| PER A | | | FN9 | | |
| RISE/FALL A | | | FN10 | | |
| SLEW A | | | FN11 | | |
| DUTY CY A | | | FN12 | | |
| GATE TIME | | | FN13 | | |
| TRIG LVL | | | FN14 | | |
| VOLTS | | | FN15 | | |
| PHASE A rel B | | | FN16 | | |
| FREQ B | | | FN17 | | |
| TIME B→A | | | FN18 | | |
| TOT A-B | FN19 | | | | |
| PULSE B | FN20 | | | | |
| DIAGNOSTICS | See text | | FN99 | | |

NOTE

An Error 1.0 will be displayed if an invalid HP IB Alpha command is sent to the 5335A.
An Error 1.1 will be displayed if an invalid HP-IB Numeric command is sent to the 5335A.

Table 3-6. 5335A Device Commands (Continued)

| Command Group | Equivalent Key/Control | Description | Command Type | Device Command |
|------------------|--|--|--------------|--------------------------|
| GATE | GATE ADJ GATE OPEN GATE CLOSE | Set GATE TIME 1 ms to one second | N | GA<#> |
| | | | T | GO |
| | | | T | GC |
| | GATE MODE | Set GATE MODE to NORM Set GATE MODE to FAST Set GATE MODE to MIN Set GATE MODE to MANUAL | I | GM0 |
| | | | I | GM1 |
| I | | | GM2 | |
| I | | | GM3 | |
| CYCLE | CYCLE MODE | Set CYCLE to NORM Set CYCLE to MIN Set CYCLE to SINGLE | I I I | CY1 CY2 CY3 |
| INPUT | SLOPE A | Set SLOPE A POSITIVE Set SLOPE A NEGATIVE | B | AS0 |
| | | | B | AS1 |
| | SLOPE B | Set SLOPE B POSITIVE Set SLOPE B NEGATIVE | B | BS0 |
| | | | B | BS1 |
| | PRESET A | Set PRESET A off Set PRESET A on | B | AP0 |
| | | | B | AP1 |
| PRESET B | Set PRESET B off Set PRESET B on | B | BP0 | |
| | | B | BP1 | |
| COM A | Set COM A off Set COM on | B | CO0 | |
| | | B | CO1 | |
| AUTO TRIG | Set AUTO TRIG off Set AUTO TRIG on | B | AU0 | |
| | | B | AU1 | |
| REAR | EXT START | External START Arm Slope Positive External START Arm off External START arm Slope Negative | I | XA1 |
| | | | I | XA2 |
| | | | I | XA3 |
| | EXT STOP | External STOP Arm Slope Positive External STOP Arm Off External STOP Arm Slope Negative | I | XO1 |
| | | | I | XO2 |
| | | | I | XO3 |
| DISPLAY | DISP REMOTE | Set display to NORMAL Set Display to REMOTE (blank display) | B | DR0 |
| | | | B | DR1 |
| | DISP DATA | Display data (with display in Remote) | N | DI<#> |
| BINARY | Request | Request 30 byte binary status Request 30 byte binary status | T | P? |
| | | | T | PQ |
| | Program | Program with binary status | * | PB<*> |
| MISC | Wait | WAIT to send mode off WAIT to send mode on | B | WA0 |
| | | | B | WA1 |
| | SRQ | Service Request disabled Service Request enabled | B | SR0 |
| | | | B | SR1 |
| | INITIALIZE | Initialize everything to default | T | IN |
| | INTERPOLATOR | Interpolator enable Interpolator disabled | B | ID0 |
| B | | | ID1 | |
| | RESET | Reset instrument for new measurement. | T | RE |
| | RANGE HOLD | Set RANGE HOLD off Set RANGE HOLD on | B | RH0 |
| B | | | RH1 | |
| | EXT ARM EN | Set EXT ARM EN off Set EXT ARM EN on | B | XE0 |
| B | | | XE1 | |
| | CHECK | Start CHECK* | T | CH |

*When selecting the CHECK function via the HP-IB, the HP5335A must NOT be in the "GA" (Gate Adj) function or a "FAIL 4.4" will result.

Table 3-6, 5335A Device Commands (Continued)

| OPTION 040 DEVICE COMMANDS | | | | | |
|----------------------------|------------------------------|-------------------------|-------------------|----------------|-----|
| COMMAND GROUP | EQUIVALENT KEY/CONTROL | DESCRIPTION | COMMAND TYPE | DEVICE COMMAND | |
| INPUT | SLOPE A | Set SLOPE A to POSITIVE | B | AS0 | |
| | | Set SLOPE A to NEGATIVE | B | AS1 | |
| | SLOPE B | Set SLOPE B to POSITIVE | B | BS0 | |
| | | Set SLOPE B to NEGATIVE | B | BS1 | |
| | PRESET A | Set PRESET A off | B | AP0 | |
| | | Set PRESET A on | B | AP1 | |
| | PRESET B | Set PRESET B off | B | BP0 | |
| | | Set PRESET B on | B | BP1 | |
| | COM A | Set COM A off | B | CO0 | |
| | | Set COM A on | B | CO1 | |
| | AUTO TRIG | Set AUTO TRIG off | B | AU0 | |
| | | Set AUTO TRIG on | B | AU1 | |
| | X10 ATTN | Set ATTN A to X1 | Set ATTN A to X10 | B | AX0 |
| | | | Set ATTN B to X1 | B | AX1 |
| Set ATTN B to X10 | | Set ATTN B to X1 | B | BX0 | |
| | | Set ATTN A to X10 | B | BX1 | |
| FILTER | Set FILTER A to off | Set FILTER A to on | B | AF0 | |
| | | Set FILTER B to off | B | AF1 | |
| | Set FILTER B to on | Set FILTER B to off | B | BF0 | |
| | | Set FILTER A to on | B | BF1 | |
| Z=50Ω | Set A Z to 1 MΩ | Set A Z to 50Ω | B | AZ0 | |
| | | Set B Z to 1 MΩ | B | AZ1 | |
| | Set B Z to 50Ω | Set A Z to 50Ω | B | BZ0 | |
| | | Set B Z to 50Ω | B | BZ1 | |
| AC | Set A to DC | Set A to AC | B | AA0 | |
| | | Set B to DC | B | AA1 | |
| | Set B to AC | Set B to DC | B | BA0 | |
| | | Set A to AC | B | BA1 | |
| TRIG ADJ | Set TRIGGER LEVEL A | N | AT<#>* | | |
| | Set TRIGGER LEVEL B | N | BT<#>* | | |
| TRIG REMOTE | Set TRIGGER LEVELS to LOCAL | B | TR0 | | |
| | Set TRIGGER LEVELS to REMOTE | B | TR1 | | |

*Where <#> is the trigger level value, from -5.00 to +5.00, programmed in the format: "AT(+/-)X.XX". For example, a plus two volt trigger level can be: "AT2", "AT2.", "AT+2.", "AT+2.0", or "AT+2.00".

3-189. Commands may be sent upper or lower case. To separate commands, you may use nothing at all or you may use any combination of spaces, commas, semicolons, carriage returns, and line feeds. Spaces are not allowed within a command name. At least one of the separation characters must follow the end of command strings. Usually this is the carriage return and line feed characters sent automatically by a write statement. For example, the command:

| Controller | 9825A | 85A |
|------------|------------------|---------------------|
| Command | wrt 703, "RE" | OUTPUT 703; "RE" |

addresses the counter as a listener and sends it the command to reset. The "wrt" (and OUTPUT) instruction automatically follows the "RE" with a carriage return and a line feed. The one exception to most of

these rules is binary programming, which uses the "wtb" (or WRITE BIN) instruction. For further information on binary programming refer to Learn Mode Programming, paragraph 3-181.

3-190. Function Selection FU, FN

3-191. This selects the function. Functions 1 through 16 are the normal functions found on the front panel. Functions above 16 are special functions (see Special Functions). These are provided to enhance system measurements. **FU99** accesses the diagnostic mode. Diagnostics are covered in Section VIII.

3-192. Gate Time Setting GA, GO, GC

3-193. This GA command is used to set the gate time remotely. The range of times is from about 1 ms to about one second. Resolution of the setting is about 2 ms, and accuracy is about 2% ±2 ms. For programmed gate times greater than one second, use GO and GC, to open and close the gate "manually":

| Controller | 9825A | HP 85A |
|------------|--|--|
| Commands | wrt 703, "GO" wait 30000 wrt 703; "GC" | OUTPUT 703; "GO" WAIT 30,000 OUTPUT 703;"GC" |

This can be useful for totalizing and for extremely long gate times.

NOTE

The 5335A makes no distinction between the GO and GC command. Each time either of these two are received the 5335A interprets it like the pressing of MANUAL Gate Mode key.

3-194. Remote Display DR0, DR1, DI

3-195. This command lets you write to the display remotely. When DR1 is sent, the display can be written to by the DI command. For example, the command:

| | |
|-------------------------|----------------------------|
| 9825A | HP 85A |
| wrt 703, "DR1, DI12345" | OUTPUT 703; "DR1, DI12345" |

causes the number given by the DI command (12345) to be formatted into engineering notation and displayed. With the display in remote, normal measurements can still be programmed, executed and output through the HP-IB, but the results will not be displayed.

3-196. Default States

3-197. The default state is equivalent to sending all commands with a parameter of zero. This may be different from the power-up state for controls that are found on the rear panel and for the INPUT section on the standard front end, due to the use of detented not momentary, switches.

3-198. For integer type commands (Type I) the default states are as follows:

| | | | |
|-----------|------------------|---------------|----------|
| FUNCTION | (FU0 is ignored) | | |
| CYCLE | CY0 | equivalent to | CY1 NORM |
| EXT START | XA0 | equivalent to | XA2 OFF |
| EXT STOP | XO0 | equivalent to | XO2 OFF |

3-199. Initialize

3-200. When INitialize is executed, the following states are NOT affected: DR, WA, SR, SO, AT & BT. The following states will be set:

- CHAN A & B PRESET ... ON
 - CHAN A & B
 - SEP/COM SEP
 - AUTO TRIG OFF
 - EXT ARM OFF
 - RANGE HOLD OFF

 - FUNCTION FREQ A
 - MATH OFF
 - STATISTICS OFF
 - GATE MODE NORM
 - CYCLE MODE NORM
 - CHAN A & B 1MΩ
 - CHAN A & B X1/X10 ... X1
 - CHAN A & B AC DC
- } Option 040

NOTE

Do not initialize ("IN") the counter when the display is in remote ("DR1"). Whenever the display is in remote, follow the initialize command with "FU1" (or any other function command). For example: wrt "5335A", "IN, FU1, DR1".

3-201. Learn Mode Programming P?, PQ, PB

3-202. The front panel can be used as the medium to tell the controller how to program the counter. This is commonly referred to as Learn Mode programming, or Binary Programming.

3-203. With the instrument in Local, the user is allowed to set up the controls in the MATH, STATISTICS, FUNCTION, GATE MODE and cycle groups in any way desired. The controller then sends a PQ command and follows this by receiving 30 bytes of binary program data. Later, when the set up is to be duplicated by the controller, the instrument is sent PB followed by the same 30 bytes of binary data.

3-204. If the data contained in the OFFSET, NORMLZ, and SCALE registers is not needed, the 30 bytes can be shortened to just 7 bytes, thus speeding the programming time. Refer to the Programming Examples beginning with paragraph 3-227.

3-205. SRQ and Status SR

3-206. The 5335A has the ability to send a request service (SRQ) message. To enable this feature, the controller must send the SR1 command.

3-207. Request service may be sent upon any error or fail message, and may be sent at the end of a measurement. When request service is sent the seventh bit (bit 7) is set. In addition to this bit, one other bit is also set, representing the status or type of service requested. If service request is not enabled, this second bit is still set, even though bit 7 is not. Table 3-7 gives the effect of each of the status bits on the service request message. When SRQ is asserted, the 5335A will turn on the "SRQ" annunciator.

3-208. The 5335A will only send SRQ if a measurement is ready for sending, and it is in the WAIT mode,

and it is not addressed to TALK or RFD is false.

(Measurement done)
AND
SRQ if: (in WAIT mode)
AND
[(if not addressed to TALK) or (RFD is false)]

NOTE

Constant reading of the status byte is not recommended. This may slow down the measurement processor time.

3-209. Program Execution/Response Times

3-210. Program speed is dependent upon the 5335A HP-IB response time. Table 3-8 provides some NOMINAL response times for various types of commands, using the 9825A calculator. The examples use the "wrt" instruction. Times are rounded up to 5 ms resolution.

3-211. Output Format

3-212. After a measurement, the 5335A outputs the data to the HP-IB. The output byte contains 19 characters which are arranged in the following format:

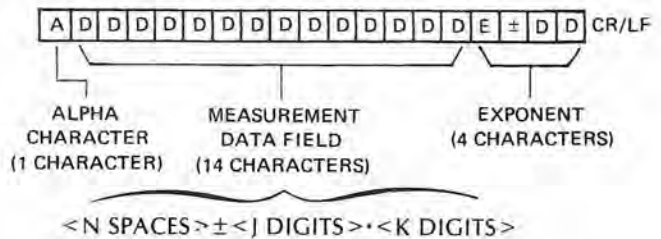

Table 3-7. Status Bits Usage with SRQ

| Bit Weight | SR Status Bits | Usage |
|------------|----------------|---|
| 1 | BIT 1 (LSB) | Set when measurement is done; and 1) 5335A is in WAIT mode and it is not yet addressed to talk, or 2) 5335A is in WAIT mode and is addressed to talk, but listening device on bus is not yet ready for data (RFD is false). |
| 2 | BIT 2 | Set when external time base used. |
| 4 | BIT 3 | Set if an ERROR has happened. |
| 8 | BIT 4 | Set if a FAIL has happened. |
| 32 | BIT 6 | Set when GATE is open. |
| 64 | BIT 7 | Set if requesting service. |
| 128 | BIT 8 | Set if in diagnostic monitor |

Table 3-8. HP-IB Response Times

| Command Mode | Device Command Code | Nominal Response Time |
|-----------------|---|-----------------------|
| Function Select | FU1 | 50 ms |
| | NOTE For RISE/FALL A, SLEW A, and PHASE allow for AUTO TRIG response time). | |
| Math Set | MS-123456789e-9 | 75 ms |
| | MD1 | 45 ms |
| Statistics Set | SN1 | 45 ms |
| | SD1 | 45 ms |
| | SM1 | 45 ms |
| | SS1 | 45 ms |
| Reset | RE | 30 ms |
| Range Hold | RH1 | 45 ms |
| Ext Arm Enable | XE1 | 45 ms |
| | XA2 | 45 ms |
| Gate Set | GM1 | 45 ms |
| | GA 29.111 | 60 ms |
| Cycle Set | CY1 | 45 ms |
| Input Set | AS1 and AP1 | 45 ms |
| | CO1 | 45 ms |
| | AU1 | 45 ms |
| Display | DR1 | 25 ms |
| | DI-123456789e-9 | 70 ms |
| | DR0 | 45 ms |
| Initialize | IN | 30 ms |
| Miscellaneous | WA1 | 45 ms |
| | SR1 | 45 ms |
| | clr (HP-IB clear) | 240 ms |
| | trg (HP-IB trigger) | 30 ms |
| | rds (HP-IB read status) | 30 ms |
| Program Binary | P? | 30 ms |
| | PB (30 bytes) | 90 ms |
| | PB (7 bytes) | 40 ms |

3-213. ALPHABET CHARACTER. One of eight single characters which specify the type of measurement. It is generally used to indicate the type of units. The alpha characters are:

- F - precedes Frequency measurements; units of Hz (Hertz)
- S - precedes Time measurement; units of s (seconds)
- V - precedes Voltage measurements; units of V (Volts)
- R - precedes Ratio measurement; no units
- T - precedes Totalize measurements; no units
- sp - precedes 1/TIME, DUTY CYCLE, PHASE; units as specified
- A - precedes A Channel TRIG LVL; units of V (Volts)

- B - precedes B Channel TRIG LVL; units of V (Volts)
- M - precedes MEAN output with SO1
- N - precedes MIN output with SO1
- X - precedes MAX output with SO1

NOTE

For Trigger Level, two complete 19 character output bytes are sent in succession. Each Channel requires a complete output sequence.

3-214. MEASUREMENT DATA FIELD. The data field consists of a 14-character string. The number begins with the sign (+ or -), followed by the digits in descending order or significance. The number,

however, is right-justified within the data field. To keep the number of characters constant within the total string, spaces (up to 10) will be inserted preceding the sign.

3-215. EXPONENT. Preceded by an "E" and the sign (+ or -), the exponent will be a multiple of 3, similar to the display which is in scientific format. On some occasions, it is possible that the format of the HP-IB output and the display will differ. Nonsignificant zeros in the display are converted to real zeros, and the output is such that there is always a significant digit left of the decimal point.

3-216. The following string illustrates a typical output byte for a FREQ A measurement of 12.3456789 MHz. The output byte is followed by a (CR) carriage return and a (LF) line feed.

F (sp) (sp) +1 2 . 3 4 5 6 7 8 9 0 E + 0 6 (CR) (LF)

NOTE

The Data Output Rate for a complete output string consisting of 19 characters plus a CR and LF is typically 8 ms.

3-217. Output Modes

3-218. The 5335A powers up with the following output modes: WA0, SR0, SO0.

3-219. When the Wait to be Addressed mode is OFF (WA0) the 5335A will output only if it is addressed to talk and RFD is true and measurement data is ready. If at the end of a measurement the 5335A finds that it is NOT addressed to talk or that RFD is false the measurement data is not sent and a new measurement is started.

3-220. When the Wait to be Addressed mode is ON (WA1) the 5335A will wait to be addressed and for RFD to be true. In this mode, new measurements are not started until the data from the previous measurement is sent, or if a command is sent.

3-221. The Wait to be Addressed mode must be active if you want an SRQ generated at the end of the measurement. Status Bit 1 can be used to monitor the 5335A for the end of measurement occurrence. This bit is effective only if the WAIT mode is ON.

3-222. When receiving trigger level data it is recommended that the WAIT mode be ON. This will assure no loss of data. However, the TRIG LVL function is

unique in that it does not show a display until after it outputs to the HP-IB. Therefore, the WAIT mode should be turned OFF if you want the display to update.

3-223. Output of Statistics

3-224. For measurements using statistics the individual measurements are not sent out. Only the result of the statistical calculation is output. The prefix alpha character will be the same as the normal measurement.

3-225. The Special Output command "SO" can be sent to tell the 5335A to send additional secondary data when statistics are enabled:

- When STD DEV is on and SO1 has been sent the following data is given in two complete strings:
STD DEV
MEAN (of the same sample, preceded with the letter "M")
- When MEAN is on and SO1 has been sent the following data is given in three complete strings:
MEAN
MIN (of the same sample, preceded with the letter "N")
MAX (of the same sample, preceded with the letter "X")

NOTE

Secondary statistical data will wait for RFD to be true if the listening device is not able to receive the data immediately.

3-226. PROGRAMMING ANOMALIES

3-227. The following items describe particular programming requirements or operations which are normal conditions, but may not be obvious or expected by the user.

- When programming Option 040, the use of REMOTE TRIGGER LEVELS and the AUTO TRIGGER mode are mutually exclusive. Sending a "TR1" (Set TRIGGER LEVELS to REMOTE) effectively prevents (or disables) the "AU1" (AUTO TRIGGER) mode from being invoked. If REMOTE TRIGGER LEVELS ("TR1") is active, and the AUTO TRIGGER ("AU1") command is sent, the AUTO TRIG key indicator will light, but the AUTO TRIG-

GER mode will not be activated. To invoke the AUTO TRIGGER mode, from the TRIGGER LEVEL REMOTE mode, the "TR0" command (Set TRIGGER LEVELS to LOCAL) must be sent first.

- When Input A has been programmed to 50 Ω and Input B has not (B defaults to 1 M Ω), sending a "CO1" (COMA) command will set Input B to 50 Ω also. However, if a "CO0" (SEP) command is then sent, Input B will remain in the 50 Ω setting. This is also true for Channel B's AC/DC coupling and X10/X1 attenuator.
- After a "DR1" (DISP REMOTE) command, if an "IN" (INITIALIZE) command is sent it must be followed by a "FN<#>" (FUNCTION) command, or the counter will appear to hang up or freeze the display.
- The INPUT B SLOPE key indicator does not correctly reflect the slope of the B channel input during functions where the INPUT A slope controls both channels.

3-228. PROGRAMMING EXAMPLES

3-229. The following HP-IB programming examples are provided for information and illustration only. Sample programs are provided for both 9825A and HP 85 Computing Controllers, and assume a 5335A address of decimal "3".

EXAMPLE 1. A) TYPICAL MEASUREMENT FORMAT

This program first dimensions a string variable in the controller for the incoming data and then sets the 5335A to its default mode (Initialize) with a gate time of 500 ms (.5 seconds). The counter will then make a simple Frequency A measurement. In step 2 the controller will read the measurement into string A, and then step 3 displays the information. After waiting for 1 second (1000 milliseconds), the program loops back into reading a "new measurement" and the cycle is repeated.

9825A EXAMPLE

```
0: dim A$[21]
1: wrt 703, "in,ga.5"
2: red 703, A$
3: dsp A$
4: wait 1000
5: gto -3
6: end
*24362
```

HP 85 EXAMPLE

```
10 DIM A$[21]
20 OUTPUT 703 ; "in,ga.5"
30 ENTER 703 ; A$
40 DISP A$
50 WAIT 1000
60 GOTO 30
70 END
```

EXAMPLE 1. B) TYPICAL MEASUREMENT FORMAT

This is an example of how the controller can be used to display a measurement once every 5 seconds. After a measurement is accepted in step 2, the HP-IBs RFD (Ready For Data) line is held false until another read instruction is executed. This means that during the wait statement in step 4, the RFD line is false. The 5335A will check the RFD line whenever it is addressed to talk to make sure that the listening device is ready for data. If it finds RFD false and the wait mode is off, the counter will skip trying to output the data and start a new measurement.

In this example the 5335A will continue to make measurements without sending data until five seconds have passed. After five seconds, the next measurement that comes is sent.

Note that this check of the RFD line is done for the first character of a measurement data string only. Subsequent characters are sent normally.

9825A EXAMPLE

```
0: dim A$[21]
1: wrt 703, "in"
2: red 703, A$
3: dsp A$
4: wait 5000
5: gto -3
6: end
*12686
```

HP 85A EXAMPLE

```

10 DIM A$(21)
20 OUTPUT 703 ;"in"
30 ENTER 703 ; A$
40 DISP A$
50 WAIT 5000
60 GOTO 30
70 END

```

EXAMPLE 2. WAIT MODE

The wa1 command tells the 5335A to wait at the end of each measurement to output data, even if not presently addressed to talk. During the 5 second wait period in step 4 if a measurement ends the counter will wait until it can send its data before starting the next measurement.

Note that if the gate time of the measurement is very short, the data that gets displayed in this example is about 5 seconds old.

9825A EXAMPLE

```

0: dim A$(21)
1: wrt 703, "in,wa1"
2: red 703, A$
3: dsp A$
4: wait 5000
5: gto -3
6: end
*22874

```

HP 85 EXAMPLE

```

10 DIM A$(21)
20 OUTPUT 703 ;"in,wa1"
30 ENTER 703 ; A$
40 DISP A$
50 WAIT 5000
60 GOTO 30
70 END

```

EXAMPLE 3. TIME INTERVAL AND PULSE WIDTH

This program will set the 5335A for a Time Interval measurement (fu2), com A (co1) and channel B slope to negative (bs1), in step 0. Step 1 causes the counter to read into the simple variable A and step 2 sets up the controller for a specific floating format. Step 3 displays the contents of the simple variable A; format:

"T.I.= _____s". After waiting for 3 seconds in step 4, the controller will set up the 5335A for a Pulse A measurement (fu7) in step 5. In step 6, the 5335A will read into the simple variable B. Step 7 will display the contents of variable B formatted as follows: "PULSE A=_____s". Following 3 seconds of waiting, the whole process is repeated.

9825A EXAMPLE

```

0: wrt 703, "in,fu2,co1,bs1"
1: red 703, A
2: flt 5
3: dsp "T.I.=", A, "sec."
4: wait 3000
5: wrt 703, "in,fu7"
6: red 703, B
7: dsp "PULSE A=", B, "sec."
8: wait 3000
9: gto 0
10: end
*6527

```

HP 85 EXAMPLE

```

10 CLEAR @ DISP USING "4/"
30 OUTPUT 703 ;"in,fu2,co1,bs1"
50 WAIT 100
70 ENTER 703 ; A
90 IMAGE "T.I.= ",D.4DE," sec."
110 DISP USING 90 ; A @ DISP
130 WAIT 1000
150 OUTPUT 703 ;"in,fu7"
170 ENTER 703 ; B
190 IMAGE "PULSE A= ",D.4DE," sec."
210 DISP USING 190 ; B
230 WAIT 2000
240 GOTO 10
250 END

```

EXAMPLE 4. RISE/FALL TIME AND SLEW RATE

In this example, step 0 sets the 5335A for Rise Time (in, fu10). After a pause of 3 seconds in step 1, (this pause is recommended to allow the Auto trigger circuitry to settle down). Step 2 will force the counter to read into simple variable A. Step 3 sets up the 9825A for a given floating format. In step 4, the 9825A will display: "RISE TIME=_____s.", showing the contents of simple register A. The controller sets up the counter for Positive Slew Rate A (fu11) in step 6, and in step 7, the 5335A reads into simple variable B. In step 8 the controller will display: "POS. SLEW RATE=_____V/S"

showing the contents of variable B. The controller sets up the counter for Fall Time (fu10 as 1) and waits for 3 seconds in steps 9 and 10. In step 11, the information from the 5335A is read into the simple variable A. The controller will display: "FALL TIME=_____s." and the contents of variable A in step 12. The 5335A is set

9825A EXAMPLE

```

0: wrt 703,"in,fu10"
1: wait 3000
2: red 703,A
3: flt 5
4: dsp "RISE TIME=",A,"sec."
5: wait 2000
6: wrt 703,"in,fu11"
7: red 703,B
8: dsp "POS. SLEW RATE=",B,"V/s"
9: wrt 703,"fu10,as1"
10: wait 3000
11: red 703,A
12: dsp "FALL TIME=",A,"sec."
13: wait 2000
14: wrt 703,"fu11"
15: red 703,B
16: dsp "NEG. SLEW RATE=",B,"V/s"
17: gto 0
18: end
*28502

```

EXAMPLE 5. DUTY CYCLE

This program will set up the 5335A for a Duty Cycle measurement (positive portion of waveform, in fu12) in step 0; then , in step 2, forces the counter to read into simple variable A. Step 3 displays the contents of variable A, format: "'UP' Duty Cycle=_____%" and maintains the display for 3 seconds (step 4). In

9825A EXAMPLE

```

0: wrt 703,"in,fu12"
1: fxd 4
2: red 703,A
3: dsp "'UP' Duty Cycle=",A,"%"
4: wait 3000
5: wrt 703,"as1"
6: red 703,B
7: dsp "'DOWN' Duty Cycle=",B,"%"
8: wait 3000
9: gto 0
10: end
*8772

```

up for a Negative Slew Rate A in step 14, and the controller reads this information into variable B in step 15; then the 9825A will show the contents of B along with the display: "NEG. SLEW RATE=_____V/S" in step 16, after which the whole process is repeated.

HP 85 EXAMPLE

```

10 CLEAR @ OUTPUT 703 ;"in,fu10"
20 WAIT 3000
30 ENTER 703 ; A
40 IMAGE "RISE TIME= ",D.4DE," sec."
50 DISP USING 40 ; A @ DISP
60 WAIT 2000
70 OUTPUT 703 ;"in,fu11"
80 ENTER 703 ; B
85 IMAGE "POS. SLEW RATE= ",D.2DE," V/sec."
90 DISP USING 85 ; B @ DISP
100 OUTPUT 703 ;"fu10,as1"
110 WAIT 3000
120 ENTER 703 ; A
125 IMAGE "FALL TIME= ",D.4DE," sec."
130 DISP USING 125 ; A @ DISP
140 WAIT 2000
150 OUTPUT 703 ;"fu11"
160 ENTER 703 ; B
165 IMAGE "NEG. SLEW RATE= ",D.2DE," V/sec."
170 DISP USING 165 ; B
175 WAIT 2000
180 GOTO 10
190 END

```

step 5, the 5335A is programmed for a Duty Cycle measurement of the negative portion of the waveform (as1) and in step 7, the 9825A will display: "'DOWN' Duty Cycle=_____%"; after waiting for 3 seconds, the total cycle is repeated.

HP 85 EXAMPLE

```

10 CLEAR @ DISP USING "4/"
20 OUTPUT 703 ;"in,fu12"
30 IMAGE "'UP' Duty Cycle= ",2D.2D," %"
40 ENTER 703 ; A
50 DISP USING 30 ; A @ DISP
60 WAIT 3000
70 OUTPUT 703 ;"as1"
80 ENTER 703 ; B
90 IMAGE "'DOWN' Duty Cycle= ",2D.2D," %"
100 DISP USING 90 ; B @ DISP
110 WAIT 3000
120 GOTO 10
130 END

```

EXAMPLE 6. MATH PROGRAMMING EXAMPLE

To demonstrate the 5335A flexibility in mathematical manipulations, apply a signal to INPUT A of different frequencies. Step 2 will request the Offset, Normalize, and Scale factors which are used to program

the 5335A in step 3. The manipulated measurement is read into string variable A (step 4). Steps 5 through 10 will print the Offset, Normalize, and Scale factors, respectively; steps 11 and 12 will print the final result.

9825A EXAMPLE

```

0: dim A$(21)
1: fxd 0
2: ent "OFFSET ?",0,"NORMALIZE ?",N,"SCALE ?",S
3: wrt 703,"in,mo",0,"mn",N,"ms",S
4: red 703,A$
5: prt "OFFSET=",0
6: spc
7: prt "NORMALIZE=",N
8: spc
9: prt "SCALE=",S
10: spc 2
11: wrt 16,"RESULT="
12: wrt 16,A#[1,1],A#[5,19]
13: end
*25419

```

9825A PRINTED RESULTS:

```

OFFSET=      100000
NORMALIZE=    50
SCALE=        25

```

```

RESULT=
F+50.5014734E+03

```

HP 85 EXAMPLE

```

10 DIM A$(21)
20 CLEAR
30 IMAGE "OFFSET=",6D.3D
40 IMAGE "NORMALIZE=",6D.3D
50 IMAGE "SCALE=",6D.3D
60 DISP "ENTER OFFSET FACTOR ?" @ INPUT O@ DISP
70 DISP "ENTER NORMALIZE FACTOR ?" @ INPUT N@ DISP
80 DISP "ENTER SCALE FACTOR ?" @ INPUT S
90 CLEAR @ DISP USING "4/"
100 OUTPUT 703 ;"in,mo";0;"mn";N;"ms";S
110 ENTER 703 ; A$
120 DISP USING 30 ; O @ DISP
130 DISP USING 40 ; N @ DISP
140 DISP USING 50 ; S @ DISP
150 DISP "RESULT=      ";A#[1,1];A#[5,19]
160 END

```

EXAMPLE 7. REMOTE DISPLAY

This program will set up the 5335A for the remote display function, to acquire a measurement, modify and format the measurement into engineering notation, and send the result to the display of the counter.

Step 0 programs the counter for Frequency A and Remote Display (fu1 dr1); the unmodified measurement then is read into simple variable A in step 1. This measurement is modified and stored in variable B (step 2), then sent to the 5335A display in step 3. The cycle is again repeated in step 4.

9825A EXAMPLE

```
0: wrt 703, "fu1dr1"
1: rrd 703, A
2: A+1e6 → B
3: wrt 703, "di", B
4: gto 1
5: end
*27213
```

HP 85 EXAMPLE

```
10 OUTPUT 703 ;"fu1dr1"
20 ENTER 703 ; A
30 B=A+1000000
40 OUTPUT 703 ;"di";B
45 WAIT 2000
50 GOTO 10
60 END
```

EXAMPLE 8. TEACH—LEARN

The following program serves as an example of the TEACH—mode (Binary Program mode). It will allow you to manually set-up the 5335A front panel, after which the 9825A will read into column matrix A, 30 bytes of binary programming data (steps 4 through 7), after which the controller will beep indicating the end of data transfer. (Information recorded: MATH, STATISTICS, FUNCTION, GATE MODE and CYCLE). Then the controller will allow the user to change the

front panel settings of the counter (steps 10 and 11). Also, it will allow the user to suppress the MATH information and thereby speeding up the transfer of data (steps 12, 13, and 14). Note however, that the OFFSET, NORMALIZE and SCALE LED will be ON although no information was transferred into their registers. In step 15 the controller will transfer all 30 bytes of binary programming data that it recorded earlier, to the 5335A; at the end of data transfer, the controller will beep twice. The counter is returned to local control in step 19, completing the exercise.

9825A EXAMPLE

```
0: dim A(30)
1: lcl 703
2: dsp "Manually set-up 5335A controls"
3: stp
4: wrt 703, "pq"
5: for I=1 to 30
6: rdb(703)}A(I)
7: next I
8: beep
9: lcl 703
10: dsp "Now, change the 5335A controls"
11: stp
12: ent "Do you need MATH functions ?", B
13: if B; gto "LONG"
14: wtb 703, "ph"
15: wtb 703, A(1), A(2), A(3), A(4), A(5), A(6), 255
```

Press CONTINUE TO RESUME

0 = SHORT DATA TRANSFER
1 = LONG DATA TRANSFER

EXAMPLE 8 (Continued)

9825A EXAMPLE (Continued)

```
16: beep
17: wait 500
18: beep
19: goto 27
20: "LONG":wtb 703,"pb"
21: for I=1 to 30
22: wtb 703,AIII
23: next I
24: beep
25: wait 500
26: beep
27: lcl 703
28: end
*28738
```

HP 85 EXAMPLE

```
10 DIM A$(30)
20 LOCAL 703
30 CLEAR @ DISP "MANUALLY SET-UP 5335A CONTROLS. PRESS 'CONT' WHEN READY."
40 PAUSE
50 OUTPUT 703 ;"pq"
60 ENTER 703 USING "#,30A" ; A$
61 LOCAL 703
62 BEEP
80 DISP "NOW, CHANGE THE 5335A CONTROLS. PRESS 'CONT' WHEN READY."
90 PAUSE
100 DISP "DO YOU NEED MATH FUNCTIONS      (Y=1 , 'N=0) ";
105 INPUT B
110 IF B<0 OR B>1 THEN 100
115 IF B THEN 170
120 OUTPUT 703 USING "#,2A,6A,B" ; "pb",A$,255
130 BEEP
140 WAIT 500
150 BEEP
160 GOTO 210
170 OUTPUT 703 USING "#,2A,30A" ; "pb",A$
180 BEEP
190 WAIT 500
200 BEEP
210 LOCAL 703
220 END
```

EXAMPLE 9. STATISTICS OUTPUT EXAMPLE

This is an example of the use of Statistic Output Format. The controller will request from the user the sample size, either 100 or 1000 (step 1); it will then program the 5335A for a Frequency A measurement with the selected sample size, and special statistics output for MEAN computation (SM1, SO1) in step 2. Step 3 causes the counter to read into the three string

variables; the contents of the strings with appropriate leader information will be printed in steps 4 through 10.

The controller will then set up the 5335A for a Standard Deviation measurement and it will store the result in the two string variables (step 11); in steps 12 through 25, the 9825A will print the contents of the variables with appropriate identification.

9825A EXAMPLE

```

0: dim A$[211],B$[211],C$[211]
1: ent "Sample size: 100/1000 (N=0/1) ?",N
2: wrt 703,"insn",N,"sm1,so1"
3: red 703,A$,B$,C$
4: prt "FREQUENCY A"
5: prt "STATISTICS"
6: spc 2
7: prt "MEAN="
8: wrt 16,A$[1,1],A$[5,19]
9: spc
10: prt "MIN="
11: wrt 16,B$[1,1],B$[5,19]
12: spc
13: prt "MAX="
14: wrt 16,C$[1,1],C$[5,19]
15: spc 3
16: beep
17: wrt 703,"sd1"
18: red 703,A$,B$
19: prt "STANDARD DEV. ="
20: wrt 16,A$[1,1],A$[5,19]
21: spc
22: prt "MEAN="
23: wrt 16,B$[1,1],B$[5,19]
24: spc 3
25: beep
26: lcl 703
27: end
*32154

```

EXAMPLE 9 (Continued)

9825A PRINTED RESULTS:

FREQUENCY A
STATISTICS

MEAN=
F+107.009501E+03

MIN=
N+106.999793E+03

MAX=
X+107.018802E+03

STANDARD DEV.=
F +3.34E+00

MEAN=
M +107.0020E+03

HP 85 EXAMPLE

```
10 DIM A$(21),B$(21),C$(21)
20 CLEAR @ DISP "Sample size: 100/1000 (N=0/1) ";
25 INPUT N
30 OUTPUT 703 ;"insn";N;"sm1,so1"
40 ENTER 703 ; A$,B$,C$
50 CLEAR @ DISP "*** FREQUENCY A STATISTICS ***"
70 DISP USING "2/"
80 DISP " MEAN= ";A$ @ DISP
110 DISP " MIN= ";B$ @ DISP
140 DISP " MAX= ";C$
160 DISP USING "3/"
161 BEEP
170 OUTPUT 703 ;"sd1"
180 ENTER 703 ; A$,B$
190 DISP "STD. DEV.= ";A$ @ DISP
220 DISP " MEAN= ";B$
270 BEEP
280 LOCAL 703
290 END
```

**EXAMPLE 10. HIGH SPEED MEASUREMENT
(COMPUTER DUMP)**

This following program will illustrate how the 5335A can be set-up to perform a high speed transfer of data with the 9825A controller. Line 2 specifies a "fast read-write buffer" labeled "SJ", allocating 2100 bytes of memory. Line 3 initializes the 5335A for a measurement; the buffer is cleared in line 4. In line 5, 100

measurements are transferred directly into buffer "SJ" from the counter; line 6 checks for a completed transfer of data, after which, the controller will beep.

The 9825A will, in lines 8 through 10, remove 21 bytes at a time from buffer "SJ" and store them temporarily in A\$, display this information as well as the measurement number; this operation is performed N times.

9825A EXAMPLE

```

0: dim A$(21)
1: 100→N
2: buf "SJ",21*N,3
3: wrt 703,"in,gm2,cy2"
4: buf "SJ"
5: tfr 703,"SJ",N*21
6: if rds("SJ")=-1;jmp 0
7: beep
8: for X=1 to N
9: red "SJ",A$
10: fxd 0
11: dsp A$,X
12: wait 500
13: next X
14: beep
15: end
*5418

```

HP 85 EXAMPLE

```

10 IMAGE 3D,7X,19A
50 DIM A$(19),B$(2108)
70 OUTPUT 703 ;"in,gm2,cy2"
90 IOBUFFER B$
110 TRANSFER 703 TO B$ FHS
130 BEEP 175,150
150 FOR X=1 TO 100
160 ENTER B$ ; A$
170 CLEAR @ DISP USING "5/"
176 DISP USING 10 ; X;A$
178 WAIT 500
180 NEXT X
190 BEEP 175,150
250 END

```

EXAMPLE 11. SERVICE REQUEST and WAIT

The following program serves as an example of the SRQ (Service Request) feature in the 5335A. As the controller is executing each program line, it logs in the interrupt request and assigns it a priority; the 9825A will finish the current line and then branch to the service routine (End of Line branching—EOL). Once the service routine is completed (by executing its "iret" statement), the main program pointer will

return to the following line from where the interrupt occurred. Line 1 sets up the 5335A into the WAIT mode and enables the sending of SRQ at the end of a measurement; line 2 specifies where to go when the 9825A receives a SRQ, and line 3 enables the use of SRQ. Line 4 simply loops, doing nothing. Lines 5 through 8 are executed whenever an SRQ from the counter is received, measurement data is then read and the counter is reset.

9825A EXAMPLE

```

0: dim A$(21)
1: wrt 703,"wa1,sr1"
2: oni 7,"SRQ"
3: eir 7
4: gto 3
5: "SRQ":
6: if bit(6,rds(703))
7: red 703,A$
8: dsp A$
9: wrt 703,"re"
10: iret
11: end
*2714
  
```

HP 85 EXAMPLE

```

10 DIM A$(21)
20 OUTPUT 703 ;"wa1,sr1"
30 ON INTR 7 GOTO 60
40 ENABLE INTR 7;8
50 WAIT 100
60 STATUS 7,1 ; T
70 IF T<>8 THEN 60
80 ENTER 703 ; A$
90 CLEAR @ DISP A$
100 OUTPUT 703 ;"re"
110 END
  
```

EXAMPLE 12. TRIGGER LEVEL

In this example, the controller will set up the counter for trigger Level function (fu14) in step 1; then the 5335A will read into two string variables A\$ and B\$ in

step 2 (two complete 19-character sets are sent out in succession, one for each channel). Steps 3 and 4 will display the contents of the string variables; the whole process is repeated in step 5.

9825A EXAMPLE

```

0: dim A$(21),B$(21)
1: wrt 703,"fu14"
2: red 703,A$,B$
3: dsp "TRIGGER LEVEL A=",A$(11,19);wait 3000
4: dsp "TRIGGER LEVEL B=",B$(11,19);wait 3000
5: gto 1
6: end
*28390
  
```

HP 85 EXAMPLE

```

10 DIM A$(21),B$(21)
20 OUTPUT 703 ;"wa1,fu14"
30 ENTER 703 ; A$,B$
35 CLEAR @ DISP USING "3/"
40 DISP "TRIGGER LEVEL A=      ";A$(11,19)
41 DISP USING "3/"
50 DISP "TRIGGER LEVEL B=      ";B$(11,19)
60 END
  
```

**3-230. Trigger Level Programming Example
(Option 040)**

3-231. The following HP-IB programming example is provided for information and illustration only. Sample programs are provided for both 9825A and HP 85A Controllers, and assume a 5335A address of decimal "28".

EXAMPLE 13. TRIGGER LEVEL PROGRAMMING

The following program sets up a time interval measurement for a triangular waveform with an amplitude of 2V p-p. The program loops through two measure-

ments, with different trigger level settings, which results in different time measurements. The instrument is labeled "SJ", and a value of 0.2 is input into "V". The 5335A is initialized ("in"), set to TIME A-B ("fu2"), with COM A ("co1"), B SLOPE Negative ("bs1"), and Trigger Levels to Remote ("tr1"). Both channel trigger levels ("at" and "bt") are set to "V" (V=0.2V). The resultant Time Interval measurement is read into "A", and displayed as "T.I.= _____ Sec". The value of "V" is changed to 0.9 ("V+.7→V"). After a two second wait, the string command is sent again, with the new value for "V" programmed into both channel trigger levels. The second measurement is read into "A" and displayed. After a two second wait, the program loops to the beginning and starts again.

9825A EXAMPLE

```

0: dev "SJ",728;flt 2
1: .2→V
2: wrt "SJ","in,fu2,col,bsl,tr1,at",V,"bt",V
3: red "SJ",A
4: dsp "T.I.=" ,A,"Sec"
5: V+.7→V
6: wait 2000
7: wrt "SJ","in,fu2,col,bsl,tr1,at",V,"bt",V
8: red "SJ",A
9: dsp "T.I.=" ,A,"Sec"
10: wait 2000
11: gto 1
12: end
*24043

```

HP 85 EXAMPLE

```

10 IMAGE 3 X,"T.I.=  ",MD.2DE," Sec."
20 S=703
30 V=.2
40 OUTPUT S ;"in,fu2,co1,bs1,tr1,at",V,"bt",V
50 ENTER S ; A
60 CLEAR @ DISP USING 10 ; A
70 DISP
80 V=V+.7
90 WAIT 2000
100 OUTPUT S ;"in,fu2,co1,bs1,tr1,at",V,"bt",V
110 ENTER S ; A
120 DISP USING 10 ; A
130 DISP
140 WAIT 2000
150 GOTO 30
160 END

```

3-232. OPTIONS

3-233. The operating characteristics of the 5335A are affected by the addition of any of the options described in the following paragraphs.

3-234. Time Base Option 010

3-235. Option 010 provides an Oven-Controlled Crystal Oscillator Time Base, that results in higher accuracy and longer periods between calibration (refer to *Table 1-1*). The oven temperature is maintained when the 5335A LINE switch is in either the ON or the STBY position (provided the instrument is connected to the power mains).

NOTE

The Option 010 Oven-Controlled-Oscillator, HP Model 10811A, is a direct replacement for the previous HP Model 10544A. Service documentation for the *older* 10544A is provided in Section VIII under Assembly A12 Oven Oscillator. All service documentation for the newer HP 10811A is provided in the HP 10811A Operating and Service Manual included with Option 010.

3-236. Digital Voltmeter Option 020

3-237. Option 020 provides a fully floating, autoranging digital voltmeter. This module measures dc inputs up to 1000 volts through front panel connectors. Refer to Specifications, *Table 1-1*, for the specific operating characteristics.

3-238. C Channel Option 030

3-239. Option 030 provides a C Channel Input Module, which expands the frequency counting range of the counter to 1.3 GHz. A front panel control adjusts the input sensitivity. A front panel preamp power receptacle is provided. Refer to Specifications, *Table 1-1*, for the specific operating characteristics.

3-240. Programmable Input Option 040

3-241. The programmable input amplifiers, Option 040, have relay-controlled and fully programmable (through the HP-IB) INPUT controls, as well as programmable trigger level. Refer to *Table 1-1* for specifications. Operating instructions are given in this section.

3-242. OPERATOR'S MAINTENANCE

3-243. The only maintenance the operator should normally perform is replacement of the primary power fuse located within the Line Module Assembly. For instructions on how to change the fuse, refer to Section II, Line Voltage Selection.

CAUTION

Make sure that only fuses with the required rated current and of the slow-blow type are used for replacement. The use of repaired fuses and the short-circuiting of fuseholders must be avoided.

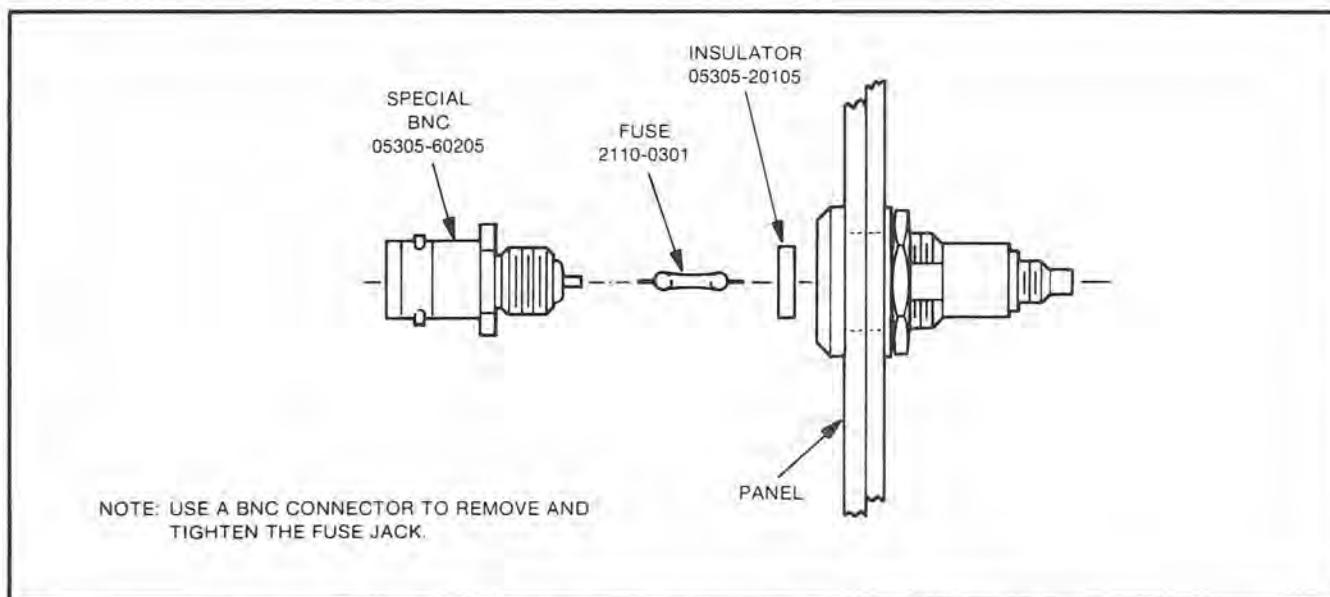

Figure 3-33. Details of Input Connector J1 and Fuse Mounting

3-244. When Option 030 C Channel is installed, the operator may be required to replace the input BNC fuse. This is a 1/8A fuse (HP Part No. 2110-0301) which is located within the INPUT C BNC connector (see *Figure 3-33* for details). To replace the fuse, disconnect the power cord, unscrew the special BNC barrel and, with needle-nose pliers, remove and replace the fuse. Reinstall the BNC barrel, and tighten using a BNC cable connector. Be careful not to overtighten.

3-245. Power/Warm-Up

3-246. The HP Model 5335A requires a power source of 100, 120, 220, or 240V ac, +5%, -10%, 48 to 66 Hz single phase. The selection of line voltage and input power fuse is described in Section II, Preparation for Use.

3-247. The 5335A has a two-position POWER switch, STBY and ON. For 5335A Option 010 only, it is important that the instrument remain connected to the power source in the STBY mode when not in use. This supplies power to the crystal oven maintaining a constant oven temperature, thus eliminating the need for a warm-up period. When the STBY mode is not used and power is disconnected from the instrument, allow 30 minutes from the application of external power in the ON mode for the instrument (crystal oven) to warm-up.

WARNING

POWER IS ALWAYS PRESENT AT THE POWER SWITCH AND TRANSFORMER, AND UNREGULATED DC IS PRESENT WHENEVER THE LINE CORD IS ATTACHED. UNPLUGGING THE POWER CORD IS NECESSARY TO REMOVE ALL POWER FROM THE INSTRUMENT.

3-248. OPERATOR'S CHECK

3-249. The following procedures will verify the basic operation of the HP 5335A Universal Counter. These tests are not intended to verify the overall accuracy or performance specifications of the instrument. They should, however, provide the operator a quick method of determining that the counter is operating properly. The tests are provided in two levels; a DISPLAY CHECK and a FRONT PANEL CHECK. The operator should perform both tests.

a. DISPLAY CHECK

To perform the HP 5335A DISPLAY CHECK, momentarily press the key labeled "CHECK". Verify that all display annunciators, except "STBY" and the A and B Channel Trigger lights, cycle ON and OFF. Pressing any Function key will return normal operation.

b. FRONT PANEL CHECK

To perform the HP 5335A FRONT PANEL CHECK, use a BNC cable to connect the rear panel TBO (Time Base Output) to the front panel INPUT A. Set the HP 5335A controls as follows:

Set Z=1M/50Ω to 50Ω

3-250. Press and hold the "CHECK" button for about three seconds. Verify that all HP 5335A display annunciators turn ON for approximately ten seconds; during which the front end amplifiers are checked for the accuracy, cross-talk, attenuation and separate/common with the input signal. Successful completion of the test loop is indicated by a display of "FE PASS". Any failures are identified by a numbered fail message. For a description of the numbered FAIL messages, refer to paragraph 3-252.

3-251. The FRONT PANEL CHECK is a built-in continuous loop, which will repeat until manually reset. To halt the test and return to normal operation, press any Function key.

3-252. ERROR/FAIL MESSAGES

3-253. Under certain conditions the 5335A will display either Error or Fail type messages. These messages typically occur during the power-up cycle. The fail messages are displayed in a continuous loop, and generally indicate a hardware related problem. Error messages indicate that the user has attempted an improper operation, either through the keyboard or the HP-IB. Refer to *Table 4-1, Error Messages*, and *Table 4-2, Fail Messages*. If a Fail message is displayed, refer to the troubleshooting information in Section VIII.

3-254. OPERATOR INSTRUCTION LABEL

3-255. *Figure 3-34* is a copy of the operator instruction label on the 5335A Top Cover.

Figure 3-34. 5335A Operating Instructions Label

5335A OPERATING INSTRUCTIONS

FUNCTION SELECTION

- KEY PER FUNCTION. SETTINGS FOR MATH, STATISTICS, RANGE HOLD, EXT ARM ENABLE, GATE/DELAY AND CYCLE ARE REMEMBERED FROM PREVIOUS FUNCTION. RETURNING TO PREVIOUS FUNCTION RETURNS THESE SETTINGS.

GATE MODES

- NORM: 20 MS-4 SEC. FAST: 100 MS-20 MS. SET VIA GATE ADJUST CONTROL.
- MIN: SHORTEST POSSIBLE GATE TIME.
- MANUAL: EACH PRESS WILL OPEN OR CLOSE THE GATE. GATE STATUS IS INDICATED BY GATE LAMP.

T.I. DELAY

- FOR MEASUREMENTS WITH T.I. DELAY, SET THE GATE MODE TO NORM, FAST, OR MANUAL. THE T.I. LAMP WILL BE ON. SETTING DELAY IS THE SAME AS FOR GATE TIME.
- FOR TIME A-B, 1/TIME A-B, AND PULSE A, SET THE GATE MODE TO MIN (NO DLY) IF T.I. DELAY IS NOT TO BE USED.

CYCLE MODES

- NORM: ~ 4 READINGS/SECOND OR LESS.
- MIN: FAST AS POSSIBLE, UP TO ~ 15 READINGS/SECOND.
- SINGLE: EACH PRESS STARTS ONE MEASUREMENT.

TRIGGER LEVELS

- AUTO TRIG OFF
 - PRESET: TRIGGER POINT IS 0V.
 - ADJUSTMENT RANGE IS -5V TO +5V.
- AUTO TRIG ON (30 Hz MINIMUM FREQUENCY)
 - PRESET: TRIGGER POINT SET TO 50% LEVEL OF INPUT SIGNAL.
 - ADJUSTMENT RANGE IS BETWEEN NEGATIVE AND POSITIVE PEAKS OF INPUT SIGNAL.

GENERAL

- MATCHED 200 MHz AMPLIFIERS, 25 MV RMS SENSITIVITY, 5V PP MAX., 2 PARTS IN 10^3 /SECOND OR 2NS BASIC RESOLUTION.
- RESET STARTS A NEW MEASUREMENT. IN TOTALIZE THE COUNT IS RESET TO ZERO, RETURNS TO LOCAL IF IN REMOTE, LLO OFF.
- RANGE HOLD FREEZES EXPONENT UNLESS OVERFLOW OCCURS.
- EXT. ARM ENABLE, WHEN ON, ALLOWS REAR PANEL ARMING OF START AND/OR STOP OF MEASUREMENT. SLOPES ARE DETERMINED BY REAR PANEL SWITCHES. EXT. GATE, SAME AS EXT. ARM WITH BOTH START AND STOP ARM ACTIVE, AND GATE MODE IN MIN.
- CHECK DOES INTERNAL SELF TEST. PRESS ANY OTHER KEY TO EXIT. SEE MANUAL IF ERROR 7.0 RESULTS.

MATH

- ALL MEASUREMENTS, EXCEPT GATE TIME AND TRG LVL, MAY BE MODIFIED BY OFFSETTING, NORMALIZING AND SCALING.

$$\text{DISPLAY} = \frac{\text{MEASUREMENT} + \text{OFFSET}}{\text{NORMLZ}} \times \text{SCALE}$$

- NUMBER ENTRY:
ENTER VALUES INTO THE OFFSET, NORMLZ, OR SCALE REGISTERS BY USING THE SHIFTED BLUE LABELED KEYS.
PRESSING ANY OF THE THREE BLUE KEYS STARTS THE NUMBER ENTRY. THAT KEY'S LAMP WILL FLASH, AND THE DISPLAY WILL SHOW THE CURRENT VALUE IN THAT REGISTER.
ENTER A NUMBER, IF NEEDED. "CHS" CHANGES SIGN OF THE MANTISSA OR EXPONENT. "EEX" STARTS EXPONENT ENTRY.
SETTING OFFSET TO "LAST DISP" SUBTRACTS THE LAST DISPLAYED VALUE FROM ALL FUTURE MEASUREMENTS. SETTING OFFSET TO "MEAS I-1" SUBTRACTS FROM EACH NEW MEASUREMENT THE VALUE OF THE PREVIOUS MEASUREMENT. MEAS I-1 IS INDICATED BY "I-1".
COMPLETE ENTRY BY PRESSING "ENTER". IF THE PARTICULAR MATH FUNCTION IS TO BE TURNED OFF PRESS "DISABLE" INSTEAD.
A MATH FUNCTION IS ON IF IT'S ASSOCIATED LAMP IS ON. DURING NORMAL OPERATION ALL ACTIVE MATH FUNCTIONS MAY BE TOGGLED ON OR OFF BY PRESSING "DISABLE".

STATISTICS

- STD. DEV. IS A SAMPLE STANDARD DEVIATION. SEE MANUAL FOR HP-IB OUTPUT.
- MEAN IS THE AVERAGE OF THE SAMPLE.
- SAMPLE SIZE TOGGLES BETWEEN 100 AND 1,000 WITH EACH PRESS OF THE N=100/K KEY.
- SMOOTH PERFORMS A RUNNING AVERAGE AND TRUNCATES UNSTABLE DIGITS.

HP-IB

- WHEN ADDRESSED TO TALK, MEASUREMENT DATA IS SENT IN THIS FORMAT:
(ALPHA) (14 CHAR DIGIT FIELD) E ± (2 DIGITS) CR/LF
- USE UNDERLINED CHARACTERS ON FRONT PANEL FOR THE TWO LETTER COMMAND NAMES
USE COMMA, SEMICOLON, SPACE, CARRIAGE RETURN/LINE FEED FOR OPTIONAL DELIMITERS.
LAST CHARACTER IN A COMMAND STRING MUST BE A DELIMITER.
- STATUS: BIT 1 (LSB) - MEASUREMENT DONE. BIT 2 - EXT. OSC. USED. BIT 3 - ERROR.
BIT 4 - FAIL. BIT 6 - GATE. ERROR 1.0 - BAD COMMAND. ERROR 1.1 - BAD NUMBER. FAIL - SEE MANUAL.
- OTHER COMMANDS - DR, DI, IN, PQ, PB, SR, WA, GO, GC, ID

SECTION IV PERFORMANCE TESTING

4-1. INTRODUCTION

4-2. The procedures in this section provide three types of tests. First, a quick method of verifying the basic operation of the HP 5335A Universal Counter. They can be performed without access to the interior of the instrument. Second, a complete performance test for the 5335A. And third, an HP-IB verification test using either the HP 9825A or HP 85A controller.

4-3. EQUIPMENT REQUIRED

4-4. Equipment required for the complete test and operation verification is listed in *Table 1-4*. Any equipment which satisfies the critical specifications given in the table may be substituted for the recommended model numbers.

4-5. TEST RECORD

4-6. Results of the operation verification should be recorded on a copy of the Operation Verification Test Card, at the end of the operation verification test. Results of the complete performance test should be recorded on a copy of the Performance Test Card at the end of this section.

4-7. ERROR/FAIL MESSAGES

4-8. Under certain conditions the 5335A will display either Error or Fail messages. These messages typically occur during the power-up cycle. The fail messages are displayed in a continuous loop, and generally indicate a hardware related problem. Error messages indicate that the user has attempted an improper operation, either through the keyboard or the HP-IB. *Table 4-1* lists the Error Messages, and *Table 4-2* lists the Fail Messages. If a Fail message is displayed, refer to the troubleshooting information in Section VIII.

Table 4-1. Error Messages

| | | |
|-----|--------------|---|
| 1.0 | HP-IB Error: | Incorrect Command |
| 1.1 | HP-IB Error: | Number out of range or incorrect number within command |
| 7.0 | Check Error: | Cable may not be connected between T.B.O. and INPUT A for extended CHECK, Diagnostic 01 or Diagnostic 14. |

Table 4-2. Fail Messages

| | | |
|------|---------|--|
| FAIL | 1.0-1.4 | ROM FAILURE (U22) |
| | 1.5-1.8 | ROM FAILURE (U23) |
| | 1.9 | ROM FAILURE (SPECIALS) |
| | 2.0 | RAM FAILURE (6802) |
| | 2.1 | RAM FAILURE (U26) |
| | 2.2 | RAM FAILURE (U25) |
| | 3.1 | OUT-BUS PROBLEM (BIT 5 OR 7) |
| | 3.2-3.3 | OUT-BUS PROBLEM (BITS 0-7, OR U8, U9, U13, U14, U6, OR U7) |
| | 3.4 | START ARM SWITCH PROBLEM |
| | 3.5 | STOP ARM SWITCH PROBLEM |
| | 4.1 | MRC STATUS REGISTER WON'T RESET (U6-U7) |
| | 4.2 | MRC E-REG WON'T RESET |
| | 4.3 | MRC T-REG WON'T RESET |
| | 4.4 | IMPROPER MID-MEAS REGISTER STATUS |
| | 4.5 | IMPROPER END-OF-MEAS REGISTER STATUS |
| | 4.6 | MRC COUNTING PROBLEM IN REG-E OR T |
| | 4.7 | MRC E-REG OVERFLOW PROBLEM |
| | 4.8 | MRC T-REG OVERFLOW PROBLEM |
| | 4.9 | MRC O/F COUNTING PROB IN REG-E OR T |
| | 5.1 | START INTERPOLATOR PROBLEM |
| | 5.2 | STOP INTERPOLATOR PROBLEM |
| | 5.3 | INTERPOLATOR COUNTING PROBLEM |
| | 5.4 | INTERPOLATOR RESET PROBLEM |
| | 6.1 | FAILURE TO MEASURE T/L REFERENCE GND |
| | 6.2 | FAILURE TO MEASURE T/L REFERENCE +5V |
| | 6.3 | FAILURE TO MEASURE T/L REFERENCE -5V |
| | 7.1 | CH-A FREQUENCY NOT CORRECT |
| | 7.2 | COM/SEP RELAY COUPLING SIGNAL TO CH-B |
| | 7.3 | CH-B UNABLE TO TRIG THRU COMMON-A |
| | 7.4 | CH-B FREQUENCY NOT CORRECT |
| | 7.5 | CH-A PRESCALER NOT FUNCTIONING PROPERLY |

4-9. LOCAL OPERATION VERIFICATION

4-10. The abbreviated checks given in paragraphs 4-13 to 4-33 can give the operator a high degree of confidence that the 5335A is operating properly, without performing a complete performance test. The operation verification is useful for incoming QA, routine maintenance, and after instrument repair. The Options 020, and 030 Operation Verification are included in these paragraphs.

4-11. The tests in the following procedure were designed to be performed sequentially. The last step in each test will leave the 5335A prepared for the next test in the sequence.

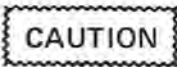

Before switching on the instrument, ensure the following:

- 1) **The transformer primary is matched to the available line voltage.**
- 2) **The correct fuse is installed.**
- 3) **All safety precautions have been observed.**

4-12. For details see Power Requirements, Line Voltage Selection, Power Cables, and associated warnings and cautions in Section II of this manual.

4-13. PRELIMINARY PROCEDURES

4-14. The following preliminary procedure steps must be performed before proceeding with the operation verification.

- a. Preset:
5335A Power Switch to STBY (OUT)

NOTE

If the 5335A line voltage selector is set to 120V the line voltage is nominally 115V.

- b. Connect:
5335A Power Cable to Line Voltage

- c. Verify:
Red Standby Lamp is ON

- d. Preset:
5335A Rear HP-IB
ADDRESS Switches to 0 (DOWN)

- e. Preset 5335A Front Panel as follows:
CHANNEL A & B:
PRESET ON (fully CCW)
1 MΩ/50Ω 50Ω (IN)
AUTO TRIG ON (IN)
CHANNEL A & B:
X10 ATTN X1 (OUT)
AC/DC DC (OUT)
SLOPES POS (OUT)
GATE ADJ fully CCW
COM A ON (IN)

4-15. Power-Up/Self Check Test Procedure I

4-16. When the counter is turned on, an internal check is made of several major components in the counter's circuitry. After the power-up sequence, the counter will initialize itself. All Math and Statistics will be OFF, the function will be FREQ. A, and the Gate and Cycle Modes will be in NORM. All of the input controls will be set according to their switch positions. If Option 040 is installed, the input switches LED will be in the "OFF" condition!

4-17. Any failures during the power-up cycle will disable the counter and produce a display of numbered ERROR or FAIL messages. For a description refer to ERROR MESSAGES, paragraph 4-7. Perform the following steps to use the POWER-UP SELF CHECK test:

NOTE

Remove any signal from INPUT A at this time.

- a. Set:
5335A Power Switch to ON (IN)
- b. Verify:
 - 1. Red Standby Lamp is OFF.
 - 2. All display and annunciator lamps turn on momentarily (excluding standby and trigger lamps).
 - 3. Display shows "HP-IB Addr 00" for about 1 second.
 - 4. Display shows "0"; Hz lamp is ON.
 - 5. FREQ A lamp is ON.
 - 6. All other lamps are off (except trigger which may be on).
 - 7. Fan is ON.
 - 8. NO FAIL or ERROR messages displayed.

4-18. Super Check Test Procedure II

4-19. The SUPER CHECK is a continuous diagnostic loop which will repeat until manually reset; during this cycle the Front End amplifiers are checked for accuracy, cross talk, attenuation and separate/common with the input signal. In addition the 5335A checks the operation of the following:

- ROMS
- RAMS
- DATA BUS
- FRONT PANEL DISPLAY
- MRC
- INTERPOLATORS

TRIGGER LEVEL REFERENCES (GND, +5V, -5V)
CHANNEL A & B TRIGGERING
SEP/COM RELAY
PRESCALER
POWER SUPPLY VOLTAGES (+5V, +3V, -5.2V)

4-20. Any failures are identified by a numbered ERROR or FAIL message. For a description refer to ERROR/FAIL MESSAGES, paragraph 4-7. If a FAIL message is displayed, refer to the troubleshooting information in Section VIII.

4-21. Perform the following steps to use the SUPER CHECK:

a. Connect a 4-foot BNC cable (HP P/N 10503A) from the 5335A rear panel TIME BASE OUT to the front panel INPUT A jack. Ensure both inputs are set to 50Ω.

b. Press 5335A keys

1. SCALE
2. SMOOTH (Display will show "SPECIAL +0")
3. 9
4. 9
5. ENTER (Display will show "DIAG 01")

c. Verify:

1. All display annunciator lamps turn ON for about 5 seconds.
2. Successful completion of the SUPER CHECK front end test loop displays the message "FE PASS" for about 15 seconds.
3. Display shows **nominal** values of three Supply Voltages:

5. 000 00 V
3. 000 00 V
-5. 200 00 V

NOTE

If TIME BASE OUT is not connected to INPUT A, ERROR 7.0 will be displayed.

4-22. Front End (Input Amplifier) Switch Test Procedure III

4-23. Perform the following steps to test the Input Amplifier switches:

a. Set 5335A front end (INPUT) switches as follows:

CHANNEL A & B:
SLOPES NEGATIVE (IN)
PRESETS OFF
ATTEN X10 (IN)
COM A ON (IN)
AUTO TRIG ON (IN)

b. Press 5335A keys:

1. SCALE, SMOOTH, 9, 9, ENTER
2. SCALE, 5, ENTER

NOTE

This diagnostic is disabled with Option 040 installed. Use Diagnostic 17 to check Option 040.

NOTE

Step (1) is not necessary when done in sequence.

c. Observe 5335A display shows "8.8.8.8.8.8.8."

d. Verify and record on test card.

e. Set 5335A front end switches as follows:

CHANNEL A & B:
SLOPES POSITIVE (OUT)
PRESETS ON
ATTEN X1 (OUT)
COM A OFF (OUT)
AUTO TRIG OFF (OUT)

f. Observe 5335A display is BLANK (no "8" showing).

g. Verify and record on test card.

h. Press the following 5335A keys:

CHANNEL A & B SLOPES
CHANNEL A & B PRESETS
CHANNEL A & B ATTN
COM A
AUTO TRIG

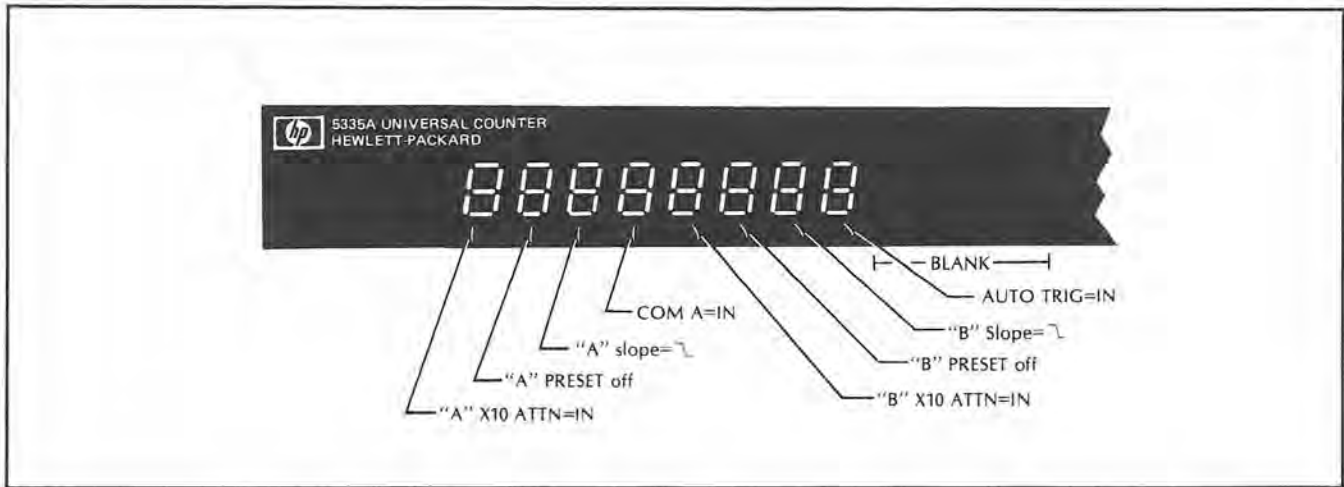

Figure 4-1. Front End Input Switch Test Display

i. Observe when the respective KEY is pressed IN the display shows a figure "8" at the corresponding digit and the display goes blank when the respective KEY is OUT, as shown in Figure 4-1.

j. Verify and record on test card.

4-24. Rear Panel External Arm Slope Switch Test Procedure IV

4-25. Perform the following steps to use the SLOPE switch test:

a. Set the HP 5335A power switch to STBY, then ON. Use an HP 3325A Synthesizer/Function Generator to input a 10 MHz 1 Vp-p sine wave to the TIME BASE IN (TBI) input at the rear of the HP 5335A.

b. Set 5335A rear panel EXTERNAL ARM START and STOP slope switches:

BOTH to Positive (UP)

c. Press the following 5335A keys:

1. SCALE, SMOOTH, 9, 9, ENTER ("Error 7.0" may be displayed; IGNORE)
2. Wait for 5 sec; SCALE, 6, ENTER

d. Observe 5335A display shows "8.8.8." (only the 4th, 6th and 8th digit ON).

e. Verify and record on test card.

f. Set 5335A rear panel EXTERNAL ARM START and STOP slope switches:

BOTH to Negative (DOWN)

g. Observe 5335A display shows "8.8.8." (only the 4th, 5th, and 7th digit ON).

h. Verify and record on test card.

i. Remove Signal from TIMEBASE IN.

j. Observe 5335A display, 4th digit goes blank.

k. Set 5335A rear panel EXTERNAL ARM START and STOP slope switches:

BOTH to OFF (MIDDLE)

l. Observe 5335A display is BLANK.

m. Verify and record on test card.

NOTE

If any 5335A front panel MATH, STATISTICS, FUNCTION, GATE MODE, or CYCLE KEY is pressed while in DIAG 06, the segments and decimal point of the 3rd digit in the display will cycle.

Refer to Figure 4-2 Rear Arm Switch Test Display.

NOTE

While in Diagnostic 06 the rear panel EXTERNAL ARM START and STOP Switch positions correspond to the Display Digits as shown in Figure 4-2 and the 3rd and 4th display digits will respond as indicated.

NOTE

You must cycle POWER SWITCH to STBY and back to ON to exit Diagnostic 06.

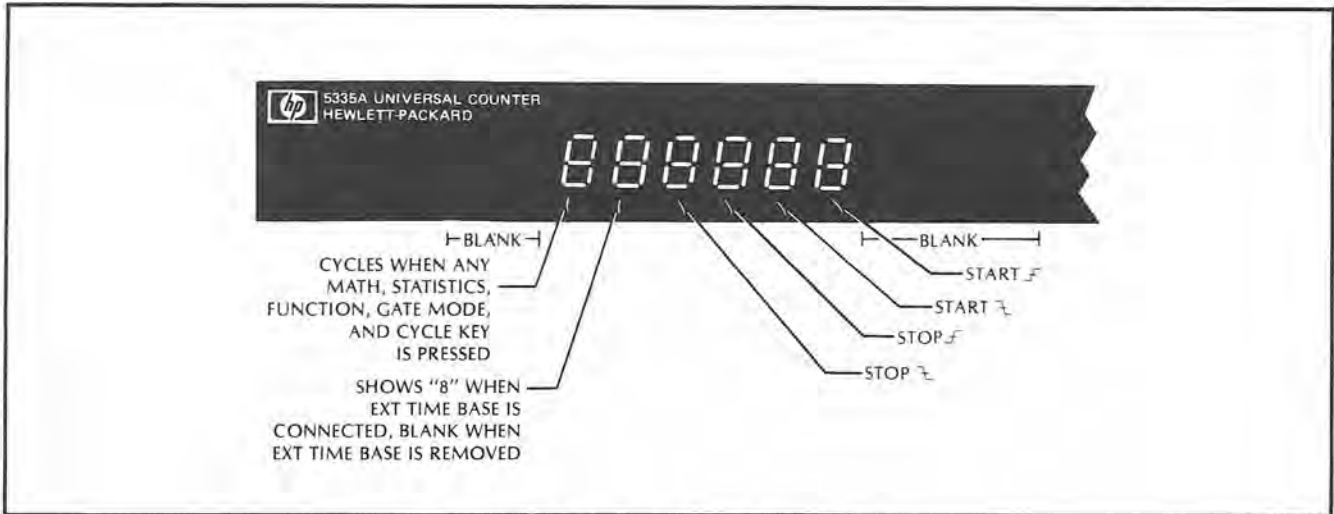

Figure 4-2. Rear Arm Switch Test Display

4-26. Keyboard Check Test Procedure V

4-27. Perform the following steps to use the keyboard test:

- a. Press 5335A keys:
 1. SCALE, SMOOTH, 9, 9, ENTER
 2. SCALE, 1, 7, ENTER (Display shows "DIAG 17")

b. Press each key on the 5335A front panel. Begin with the upper left key (MATH DISABLE) and go down each column until the lower right key is pressed.

c. Observe as each key is pressed:

1. The "+0" EXPONENT will light and two digits on the display will match digits in Figure 4-3.
2. The key's lamp will turn ON (except for RESET, CHECK, and CYCLE NORM, which have no lamp).

d. Verify and record on test card.

NOTE

You must cycle Power Switch to STBY and back to ON to exit the KEYBOARD CHECK.

NOTE

INPUT section if for Option 040 only.

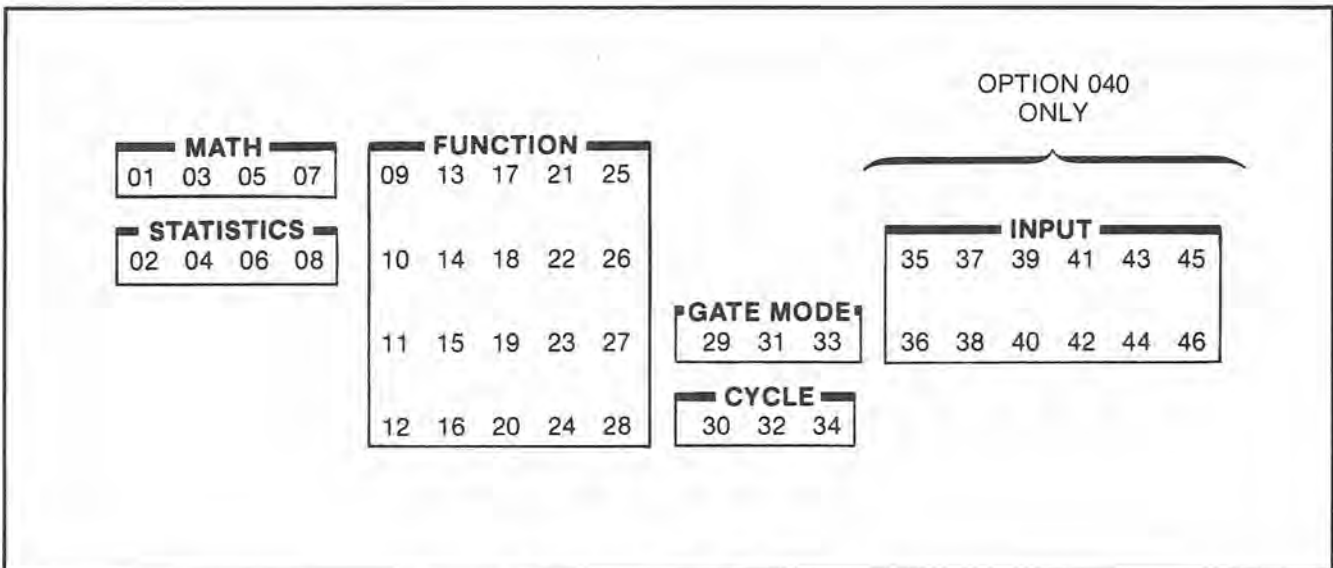

Figure 4-3. Keyboard Check Key Assignments

4-28. DVM Test (Option 020) Procedure VI

4-29. Perform the following steps to use the DVM test:

- a. Connect a 4-foot BNC cable from the 5335A rear panel Trigger Level "A" or "B" to the DVM input jack. (Use a BNC-to-banana connector.)
- b. Set:
CHANNEL A & B:
PRESET OFF (in CCW position)
AUTO TRIG OFF
- c. Press:
5335A Key VOLTS
- d. Observe:
Display shows approx. "-5.2XX" V
- e. Invert the DVM input terminal connector.
- f. Observe:
Display shows approx. "+5.2XX" V
- g. Verify and record on test card.

4-30. Channel "C" Test (Option 030) Procedure VII

4-31. Perform the following steps to use the Channel "C" test:

- a. Connect the following:
 - 1. The HP 86603A to the 5335A Channel C INPUT.

2. The HP 8660C Time Base Out to the 5335A Time Base IN.

- b. Press:
5335A Key FREQ C
- c. Vary the frequency of the HP 8660C.
- d. Observe the 5335A display shows the output frequencies of the HP 8660C within the C Channel published Specs.
- e. Verify and record on test card.

4-32. Programmable Input Amplifier Test (Option 040) Procedure VIII

4-33. Perform the following steps to use the Option 040 INPUT test:

- a. Connect the 5335A Trigger Levels OUT A&B (rear panel) to the 1740A oscilloscope as shown in Figure 4-4.
- b. On the 5335A, press: SCALE, SMOOTH, 9, 9, ENTER. Then press: SCALE, 3, 4, ENTER.
- c. Set the oscilloscope channel A&B to zero reference in the middle of the screen. Also set the vertical scale in both scope channels to 2 volts/div.
- d. Observe the scope display sweeping vertically from -5.11 volts to +5.11 volts, for both Channels A and B.
- e. Verify and record on test card.

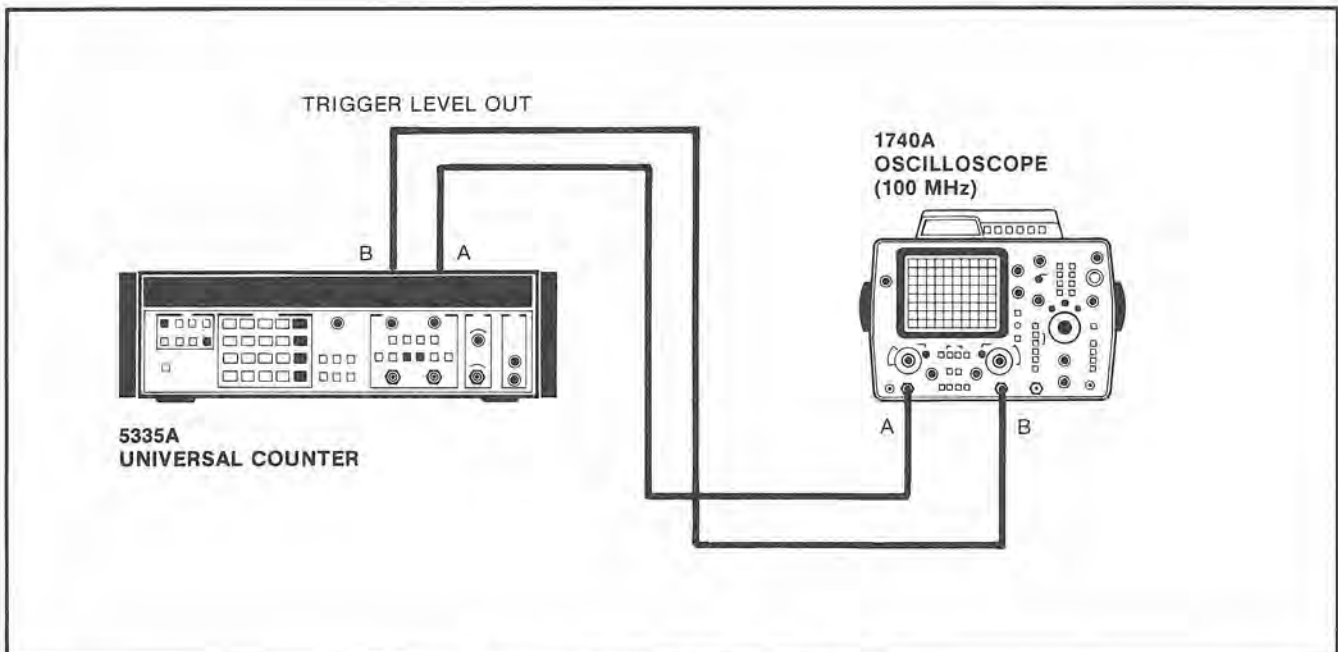

Figure 4-4. Option 040 DAC Test Setup

4-34. PERFORMANCE TEST FOR THE 5335A AND ALL OPTIONS

4-35. The following procedures can be used as Performance Test for the 5335A Universal Counter and all its options. Results of Performance Test may be tabulated on the 5335A Performance Test Card.

4-36. The procedures listed were designed to be performed **sequentially**; this is particularly true for tests II and III, and also, for tests X, XI. The tests included are as follows:

- I POWER-UP/SELF TEST
- II SUPERCHECK
- III KEYBOARD CHECK
- IV REAR PANEL/EXTERNAL ARM SWITCH TEST
- V GATE TIME
- VI CHANNEL A and B FREQUENCY RESPONSE and SENSITIVITY
- VII RATIO A/B
- VIII TIME INTERVAL AND INVERSE TIME INTERVAL
- IX PULSE WIDTH A AND PULSE WIDTH B
- X RISE AND FALL TIME A
- XI SLEW RATE A
- XII PHASE A rel B
- XIII DVM TEST (OPTION 020)
- XIV CHANNEL C TEST (OPTION 030)
- XV PROGRAMMABLE FRONT END (OPTION 040)

4-37. Power-Up/Self Check Test Procedure I

4-38. DESCRIPTION: The 5335A Universal Counter power is set to STBY, then ON; the counter will be cycled through its Power-up subroutine. This test is performed with **NO** External Time Base signal applied to the counter. A function test is made of all major functional blocks, after which, the 5335A will go to its default state.

4-39. Perform the following steps to use the Power-Up Self Check:

- a. Set the 5335A front panel GATE ADJ to fully counterclockwise position.

b. Set the 5335A power switch to STBY, then to ON. Verify that:

1. Red LED "STBY" lamp is OFF.
2. All display and annunciator lamps turn ON momentarily (excluding "STBY" and trigger lamps).
3. Display shows the selected HP-IB address.
4. "FREQ A" and "Hz" lamps are ON; display shows: "0."
5. All other lamps are OFF (except Trigger lamps which may be on).
6. Fan is ON.

c. Record results on test card (PASS/FAIL).

4-40. Supercheck Test Procedure II

4-41. DESCRIPTION: SUPERCHECK is a continuous diagnostic loop which will repeat until manually reset. A signal is applied to INPUT A and the front end amplifiers are checked for accuracy, crosstalk and attenuation; the 5335A "kernel" and its major supporting blocks are also checked. The 5335A should display the expected results.

NOTE

This SUPERCHECK test and the following KEYBOARD CHECK test **MUST** be performed sequentially.

4-42. Perform the following steps to use the SUPERCHECK test:

a. Connect a 4-foot BNC cable (HP P/N 10503A) from the 5335A rear panel TIME BASE OUT 10 MHz (TBO) to the front panel INPUT A jack.

b. Set Channel A 1 M Ω /50 Ω impedance switch to the 50 Ω position (IN).

- c. Press:
 - SCALE (verify SCALE lamp is flashing)
 - SMOOTH (display shows: "SPECIAL +0")
 - 9
 - 9
 - ENTER (display will show "DIAG 01")

d. Verify:

1. All display annunciator lamps turn ON for about 5 seconds.
2. After successful completion of the Front End Input test, the display shows: "FE PASS", for about 15 seconds.

3. Display shows **NOMINAL** values of 3 supply voltages:

+5. 000 00 V
+3. 000 00 V
-5. 200 00 V

4. Test then repeats itself.

NOTE

If TIME BASE OUT is not connected to INPUT A, ERROR 7.0 will be displayed.

5. Record results on test card (PASS/FAIL).

4-43. Keyboard Check Test Procedure III

4-44. DESCRIPTION: This subroutine is designed to verify the ability of the microprocessor to identify an individual software-read front panel momentary switch when it is pressed. When this subroutine is enabled, a number should be displayed on the 5335A when any switch is pressed, corresponding to *Figure 4-5*. The selected key LED will remain ON while the number is being displayed. A "+0" will be displayed in the exponent section of the display during the test.

4-45. Perform the following steps to use KEYBOARD test:

- a. Press: SCALE 1, 7, ENTER (Display shows "DIAG 17").
- b. Press each key on the 5335A front panel. Begin with the upper left key (MATH DISABLE) and go down each column until the lower right key is pressed.

NOTE

INPUT section is for Option 040 only.

- c. As each key is pressed observe:

1. The "+0" EXPONENT will light and a 2-digit display will actively correspond to *Figure 4-5*.
2. The key's lamp will turn ON (except for RESET, CHECK, and CYCLE NORM, which have no lamps).

- d. Record results on test card (PASS/FAIL).

4-46. Rear Panel — External Arm Switch Test Procedure IV

4-47. DESCRIPTION: The 5335A Universal Counter is programmed to test its A6 Rear Panel Arming switches in their different modes of operations; also tested is the External Time Base Input circuitry. *Figure 4-6* shows display results of this test.

4-48. Perform the following steps to use the EXTERNAL ARM switch test:

- a. Set the HP 5335A power switch to STBY, then ON. Use an HP 3325A Synthesizer/Function Generator to input a 10 MHz 1 Vp-p sine wave to the TIME BASE IN (TBI) input at the rear of the HP 5335A. Set the HP 5335A rear panel EXTERNAL ARM START and STOP slope switches to positive (up) position.
- b. Press: SCALE, SMOOTH, 9, 9, ENTER ("ERROR 7.0" may be displayed; IGNORE).
- c. Wait for 5 seconds, press: SCALE, 6, ENTER.
- d. Observe that 5335A displays "eights" in the 4th, 6th, and 8th positions. Also, EXTERNAL TIME BASE lamp will be ON.

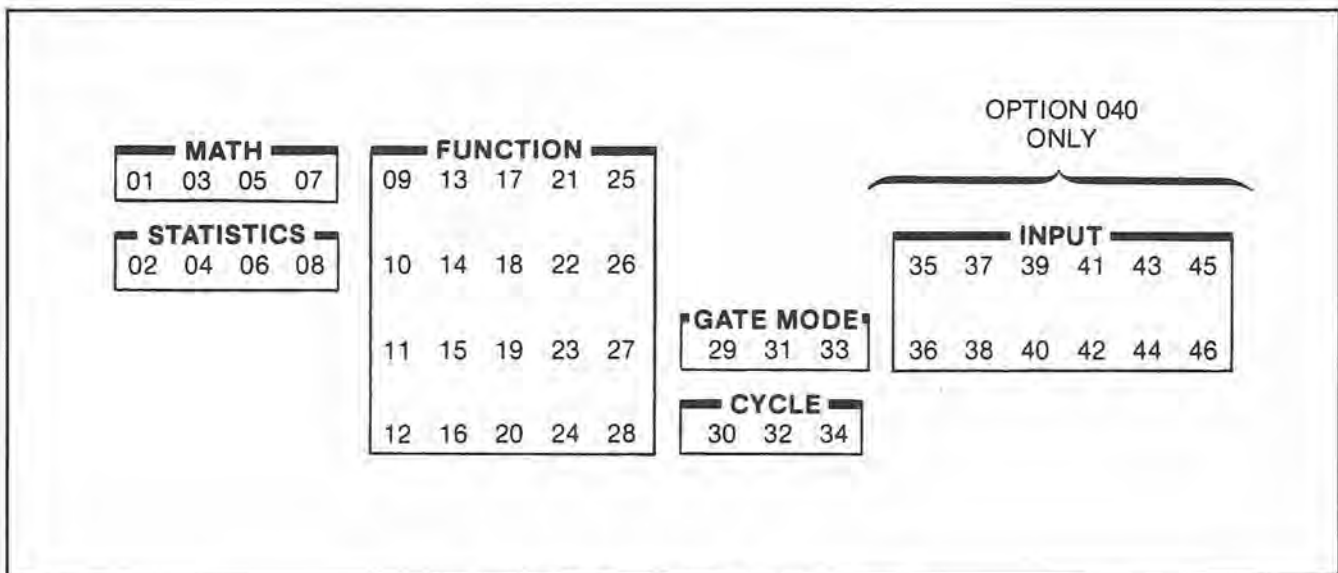

Figure 4-5. Keyboard Check Key Assignments

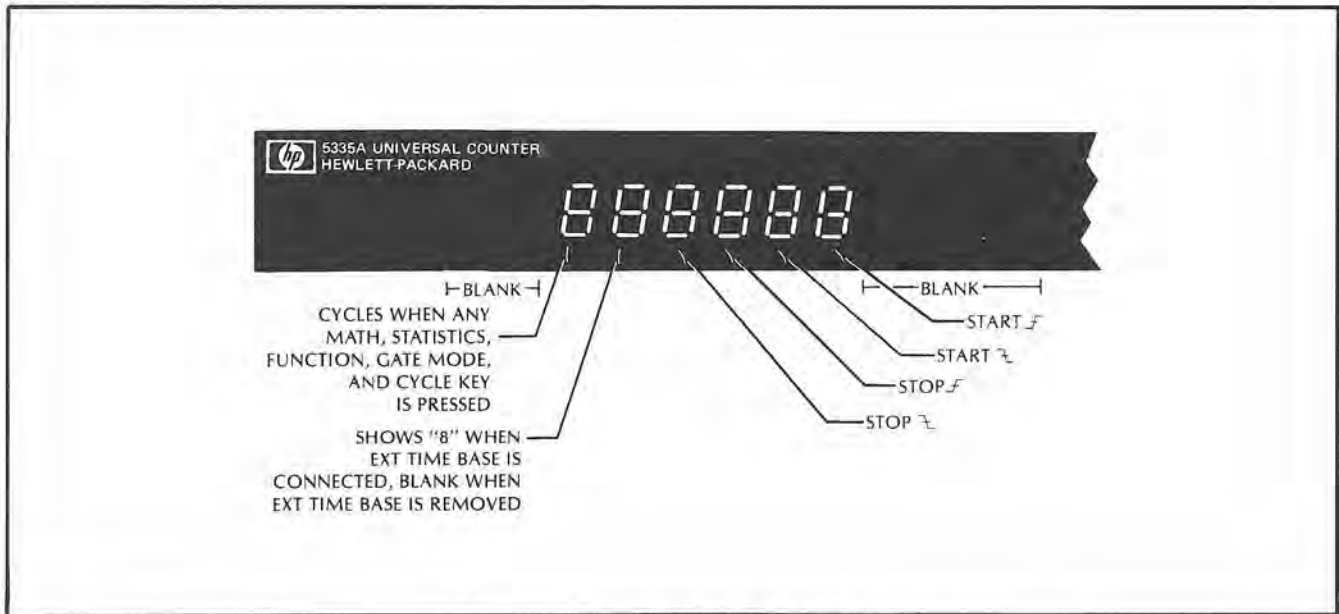

Figure 4-6. Rear Arm Switch Test Display

- e. Set EXTERNAL ARM START and STOP slope switches to Negative (DOWN) position. Observe counter display showing "eights" in the 4th, 5th, and 7th positions.
- f. Remove BNC cable from TBI; set EXTERNAL ARM START and STOP slope switches to OFF (MIDDLE) position.
- g. Observe 5335A display is BLANK.
- h. Record results on test card (PASS/FAIL).

NOTE

If any 5335A front panel MATH, STATISTICS, FUNCTION, GATE MODE, or CYCLE key is pressed while in Diagnostic 06, the segments and decimal point of the 3rd digit in the display will cycle.

4-49. Gate Time Test Procedure V

4-50. SPECIFICATIONS: NORM: 20 milliseconds to 4 seconds, NOMINAL. FAST: 100 μ s to 20 milliseconds, NOMINAL.

4-51. DESCRIPTION: The 5335A Universal Counter variable gate time function is exercised in both of its ranges. The counter is set to its GATE TIME function, and the gate time is varied throughout its range. The 5335A should display the correct count.

4-52. Perform the following steps to use the GATE TIME test:

- a. Set the 5335A power switch to STBY, then ON.

- b. Set the 5335A front panel controls as follows:

GATE MODE NORM
 CYCLE NORM
 FUNCTION GATE TIME
 GATE ADJ fully ccw

- c. Vary the GATE ADJ control from full ccw to full cw position; the 5335A should display from less than 20 ms to greater than 4 seconds.
- d. Record result on test card (PASS/FAIL).
- e. Set GATE MODE to "FAST" (lamp ON). Vary the GATE ADJ pot from full ccw to full cw position; observe the 5335A displaying fast gate time from less than 100 μ s to greater than 20 ms.
- f. Record results on test card (PASS/FAIL).

4-53. Channel A and B Frequency Response and Sensitivity Test Procedure VI

4-54. Channel A Test

4-55. SPECIFICATIONS: 0 to 200 MHz (prescaled by 2); 25 mV rms sine wave.

- a. DC coupled: 0 to 200 MHz.
- b. AC coupled (1 M Ω): 30 Hz to 200 MHz.
- c. AC coupled (50 Ω): 200 kHz to 200 MHz.

4-56. DESCRIPTION: A signal generator with calibrated output is set to the specified 5335A channel A minimum signal sensitivity level. The frequency is slowly increased from dc up to 20 MHz at constant

level, and the 5335A reading is checked for the proper count. For the range of 20 MHz to 200 MHz, a different generator is used. Connect test equipment as shown in *Figure 4-7*.

4-57. Perform the following steps to use the Frequency Response test:

a. Set the 5335A front panel controls as follows:

```

FUNCTION ..... FREQ A
MATH ..... Off (LEDs off)
STATISTICS ..... Off (LEDs off)
GATE MODE ..... NORM
GATE ADJ ..... fully ccw
CYCLE ..... NORM
INPUT (Channel A and B):
  1 MΩ/50Ω ..... 50Ω (ON)
  Trigger Level ..... PRESET
  X10/X1 ATTN ..... X1 (OUT/OFF)
  AC/DC ..... DC (OUT/OFF)
  FILTER (Option 040) ..... OFF
  AUTO TRIG ..... OUT (OFF)
  COM A ..... OUT (OFF)
    
```

DC to 20 MHz (dc coupled)

b. Connect the 3325A Synthesizer/Function Generator to the 5335A INPUT A as in *Figure 4-7*.

c. Set the 3325A to output a 0.01 Hz sine wave at 25 mV rms. Increase the frequency of the 3325A, and verify that the 5335A displays the proper frequency from 0.01 Hz up to 20 MHz.

d. Measure actual sensitivity by decreasing the 3325A level until the 5335A gives an unstable count at these frequencies: 0.01 Hz, 10 Hz, 100 kHz, 10 MHz, 20 MHz.

e. Record results on test card (VALUE).

30 Hz to 20 MHz (ac coupled; 1 MΩ)

f. Set Channel A 1 MΩ/50Ω switch to 1 MΩ; set the AC/DC switch to ac coupling. Set the 3325A through a 50Ω feedthrough to the 5335A INPUT A. Set the 3325A to output a 30 Hz sine wave at 25 mV rms. Increase the frequency of the 3325A, and verify that the 5335A displays the proper frequency from 30 Hz to 20 MHz.

g. Measure actual sensitivity by decreasing the 3325A level until the 5335A gives an unstable count at these frequencies: 30 Hz, 10 kHz, 1 MHz, 10 MHz, 20 MHz.

h. Record results on test card (VALUE).

200 kHz to 20 MHz (ac coupled; 50 ohms)

i. Remove the 50Ω feedthrough from INPUT A. Set Channel A 1 MΩ/50Ω switch to 50Ω; set the 3325A to output a 200 kHz sine wave at 25 mV rms. Increase the frequency of the 3325A and verify that the 5335A displays the proper frequency from 200 kHz to 20 MHz.

j. Measure actual sensitivity by decreasing the 3325A level until the 5335A gives an unstable count at these frequencies: 200 kHz, 500 kHz, 1 MHz, 10 MHz, 20 MHz.

k. Record results on test card (VALUE).

20 MHz to 200 MHz (dc coupled)

l. Connect the HP 8654A Signal Generator to the 5335A INPUT A as shown in *Figure 4-8*.

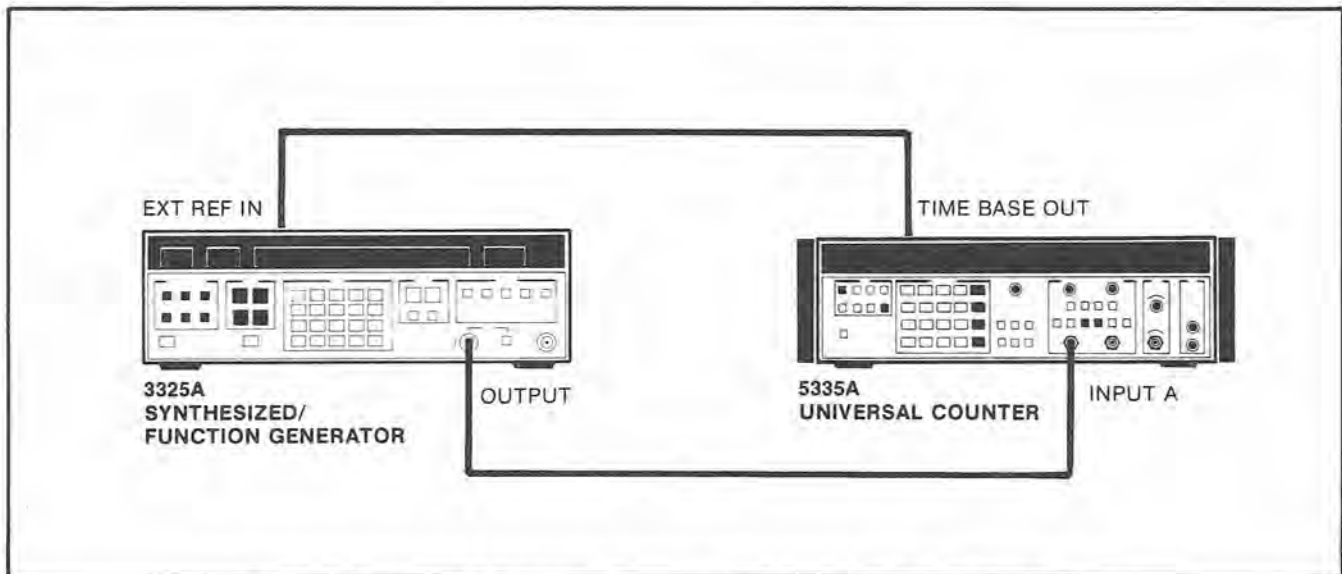

Figure 4-7. Channel A Frequency Response and Sensitivity Test Setup (20 MHz)

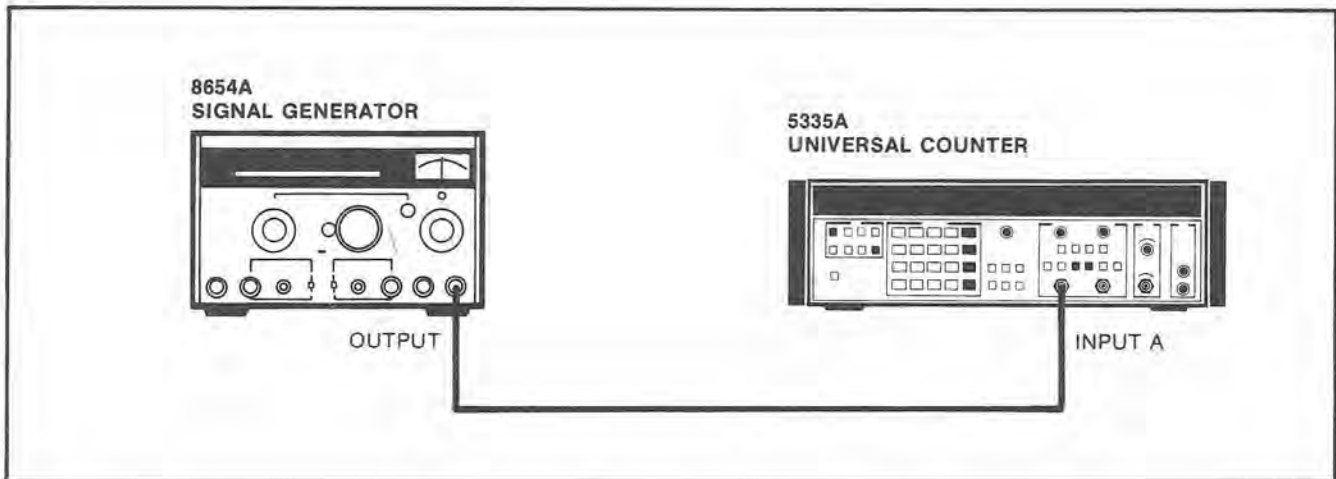

Figure 4-8. Channel A Frequency Response and Sensitivity Test Setup (200 MHz)

m. Set Channel A AC/DC switch to **dc** coupling. Set the 8654A to output a 20 MHz sine wave at 25 mV rms. Increase the frequency of the 8654A, and verify that the 5335A displays the proper frequency from 20 MHz to 200 MHz.

n. Measure actual sensitivity by decreasing the 8654A level until the 5335A gives an unstable count at these frequencies: 20 MHz, 50 MHz, 125 MHz, 200 MHz.

o. Record results on test card (VALUE).

20 MHz to 200 MHz (ac coupled)

p. Set Channel A AC/DC switch to **ac** coupling; set the 8654A to output a 20 MHz sine wave at 25 mV rms. Increase the frequency of the 8654A and verify that the 5335A displays the proper frequency from 20 MHz to 200 MHz.

q. Measure actual sensitivity by decreasing the 8654A level until the 5335A gives an unstable count at these frequencies: 20 MHz, 50 MHz, 125 MHz, 200 MHz.

r. Record results on test card (VALUE).

4-58. Channel B Test

4-59. SPECIFICATIONS: 0 to 100 MHz; 25 mV rms sine wave:

- DC coupled: 0 to 100 MHz.
- AC coupled (1 M Ω): 30 Hz to 100 MHz.
- AC coupled (50 Ω): 200 kHz to 100 MHz.

4-60. DESCRIPTION: A signal generator with calibrated output is set to the specified 5335A Channel B minimum signal sensitivity level. The frequency is

slowly increased from dc up to 20 MHz at constant level, and the 5335A reading is checked for the proper count. For the range of 20 MHz to 100 MHz, a different generator is used.

4-61. Perform the following steps to use the B Frequency Response Test:

a. Press: SCALE, SMOOTH, 1, 7, ENTER. This will enable special function Frequency B.

DC to 20 MHz (dc coupled)

b. Connect the 3325A Synthesizer/Function Generator to the 5335A INPUT B as in shown Figure 4-9.

c. Set the 3325A to output a 0.01 Hz sine wave at 25 mV rms. Increase the frequency of the 3325A and verify that the 5335A displays the proper frequency from 0.01 Hz up to 20 MHz.

d. Measure actual sensitivity by decreasing the 3325A level until the 5335A gives an unstable count at these frequencies: 0.01 Hz, 10 Hz, 100 kHz, 10 MHz, 20 MHz.

e. Record results on test card (VALUE).

30 Hz to 20 MHz (ac coupled; 1 M Ω)

f. Set Channel B 1 M Ω /50 Ω switch to **1 M Ω** ; set the AC/DC switch to ac coupling. Connect the 3325A through a 50 Ω feedthrough to the 5335A INPUT B. Set the 3325A to output a 30 Hz sine wave at 25 mV rms. Increase the frequency of the 3325A and verify that the 5335A displays the proper frequency from 30 Hz to 20 MHz.

g. Measure actual sensitivity by decreasing the 3325A level until the 5335A gives an unstable count at these frequencies: 30 Hz, 10 kHz, 1 MHz, 10 MHz, 20 MHz.

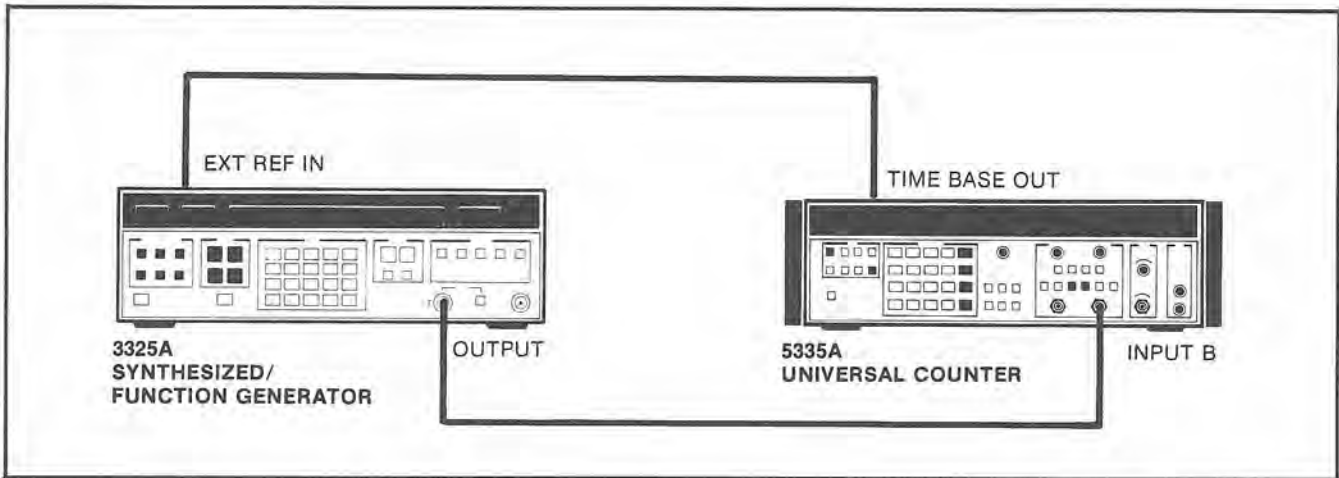

Figure 4-9. Channel B Frequency Response and Sensitivity Test Setup (20 MHz)

h. Record results on test card (VALUE).

200 kHz to 20 MHz (ac coupled; 50Ω)

i. Remove the 50Ω feedthrough from INPUT B. Connect the 3325A OUTPUT to the 5335A INPUT B. Set Channel B 1 MΩ/50Ω switch to 50Ω; set the 3325A to output a 200 kHz sine wave at 25 mV rms. Increase the frequency of the 3325A and verify that the 5335A displays the proper frequency from 200 kHz to 20 MHz.

j. Measure actual sensitivity by decreasing the 3325A level until the 5335A gives an unstable count at these frequencies: 200 kHz, 500 kHz, 1 MHz, 10 MHz, 20 MHz.

k. Record results on test card (VALUE).

20 MHz to 100 MHz (dc coupled)

l. Connect the HP 8654A Signal Generator to the 5335A INPUT B as shown in Figure 4-10.

m. Set Channel B AC/DC switch to **dc** coupling. Set the 8654A to output a 20 MHz sine wave at 25 mV rms. Increase the frequency of the 8654A and verify that the 5335A displays the proper frequency from 20 MHz to 100 MHz.

n. Measure actual sensitivity by decreasing the 8654A level until the 5335A gives an unstable count at these frequencies: 20 MHz, 50 MHz, 100 MHz.

o. Record results on test card (VALUE).

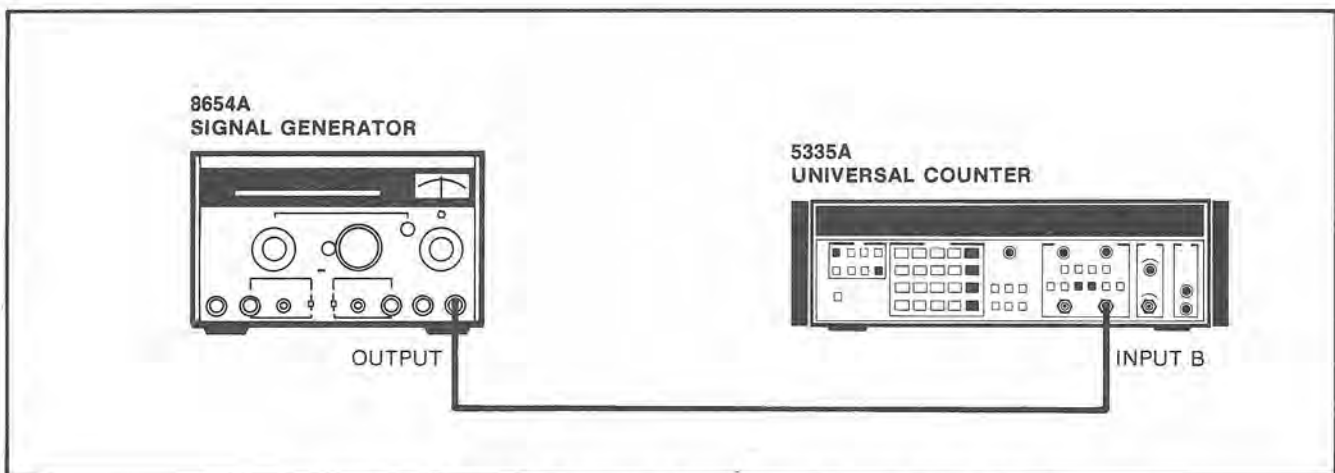

Figure 4-10. Channel B Frequency Response and Sensitivity Test Setup

20 MHz to 100 MHz (ac coupled)

p. Set Channel B AC/DC switch to **ac** coupling; set the 8654A to output a 20 MHz sine wave at 25 mV rms. Increase the frequency of the 8654A and verify that the 5335A displays the proper frequency from 20 MHz to 100 MHz.

q. Measure actual sensitivity by decreasing the 8654A level until the 5335A gives an unstable count at these frequencies: 20 MHz, 50 MHz, 100 MHz.

r. Record results on test card (VALUE).

4-62. Ratio A/B Function Test Procedure VII

4-63. SPECIFICATIONS: Channel A, 0 to 200 MHz (prescaled by 2). Channel B, 0 to 100 MHz

4-64. DESCRIPTION: A signal generator with calibrated output drives channels A and B of the 5335A under test. The counter is set to RATIO A/B and COM A input. The test is setup so that the counter will display a continuous ratio of "1", over the frequency range of 0 to 20 MHz. For the range of 20 MHz to 200 MHz, a different generator is used.

4-65. Perform the following steps to use the RATIO A/B test:

a. Set the 5335A front panel controls as follows:

FUNCTION RATIO A/B
 MATH Off (LEDs off)
 STATISTICS Off (LEDs off)
 GATE MODE NORM
 CYCLE NORM
 GATE ADJ fully ccw

INPUT (Channel A and B):

1 M Ω /50 Ω 50 Ω (ON)
 Trigger Level PRESET
 X10/X1 ATTN X1 (OUT/OFF)
 AC/DC DC (OUT/OFF)
 FILTER (Option 040) OFF
 AUTO TRIG OUT (OFF)
 COM A IN (ON)

0 to 20 MHz.

b. Connect the 3325A Synthesizer/Function Generator to the 5335A INPUT A as shown in *Figure 4-11*.

c. Set HP 3325A to 10 Hz, 10 kHz, 5 MHz, and 20 MHz at 25 mV rms sine wave. The 5335A should display a stable ratio as shown:

| HP 3325A | HP 5335A display: |
|----------|-------------------|
| 10 Hz | 1. |
| 10 KHz | 1.00 |
| 5 MHz | 1. 000 0 |
| 20 MHz | 1. 000 00 |

d. Record results on test card (PASS/FAIL).

20 MHz to 200 MHz.

e. Connect the HP 3325A Synthesizer/Function Generator and the HP 8660C Synthesized Signal Generator to the 5335A as shown in *Figure 4-12* (the 8660C, 3325A, and the 5335A time bases shall be locked together).

f. Set the HP 5335A front panel COM A to OFF (OUT) position. Set the HP 3325A to output a 20 MHz at 25 mV rms sine wave. Set the HP 8660C to output a 50 MHz, 100 MHz, 150 MHz, 200 MHz at 25 mV rms sine wave. Verify that the 5335A displays (± 1 count): 2. 500 00, 5. 000 00, 7. 500 00, 10. 000 00, respectively.

g. Record results on test card (PASS/FAIL).

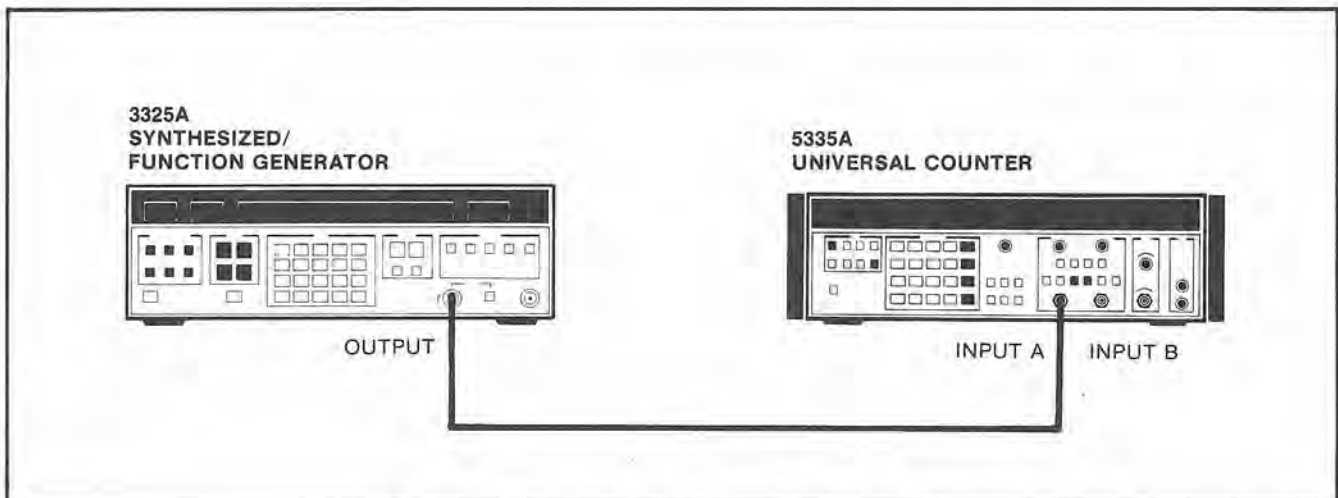

Figure 4-11. Ratio A/B Test Setup (10 Hz to 20 MHz)

4-66. Time Interval and Inverse Time Interval Test Procedure VIII

4-67. Specifications:

- a. Time Interval: 0 ns to 10⁺⁷ seconds.
- b. Inverse Time Interval: 10⁻⁷ to 10⁺⁹ seconds.

4-68. DESCRIPTION: A function generator with calibrated output drives channels A and B of the 5335A under test, with a square wave signal. The counter is set to TIME A→B and COM A input. The 5335A should display the proper count. The 5335A and the signal generator time bases shall be locked together.

4-69. Perform the following steps to use the Time Interval test:

- a. Connect the 3325A Synthesizer/Function Generator to the 5335A INPUT A as shown in Figure 4-13.

b. Set the 5335A front panel controls as follows:

- FUNCTION TIME A→B
- MATH Off (LEDs off)
- STATISTICS Off (LEDs off)
- GATE MODE MIN (LED ON)
- CYCLE NORM
- GATE ADJ fully ccw
- INPUT (Channel A and B):
 - 1 MΩ/50Ω 50Ω (ON)
 - Trigger Level PRESET
 - X10/X1 ATTN X1 (OUT/OFF)
 - AC/DC DC (OUT/OFF)
 - Channel A Slope POS (OUT/OFF)
 - Channel B Slope NEG (IN/ON)
 - FILTER (Option 040) OFF
 - AUTO TRIG OUT (OFF)
 - COM A IN (ON)

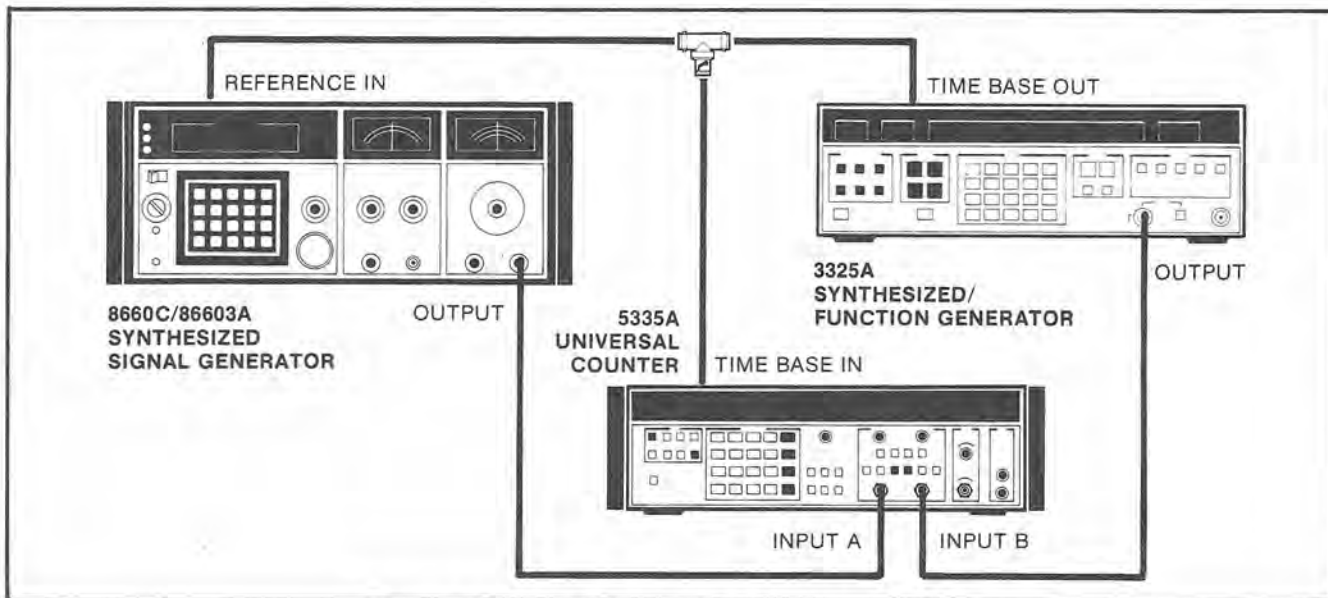

Figure 4-12. Ratio A/B Test Setup (20 MHz to 200 MHz)

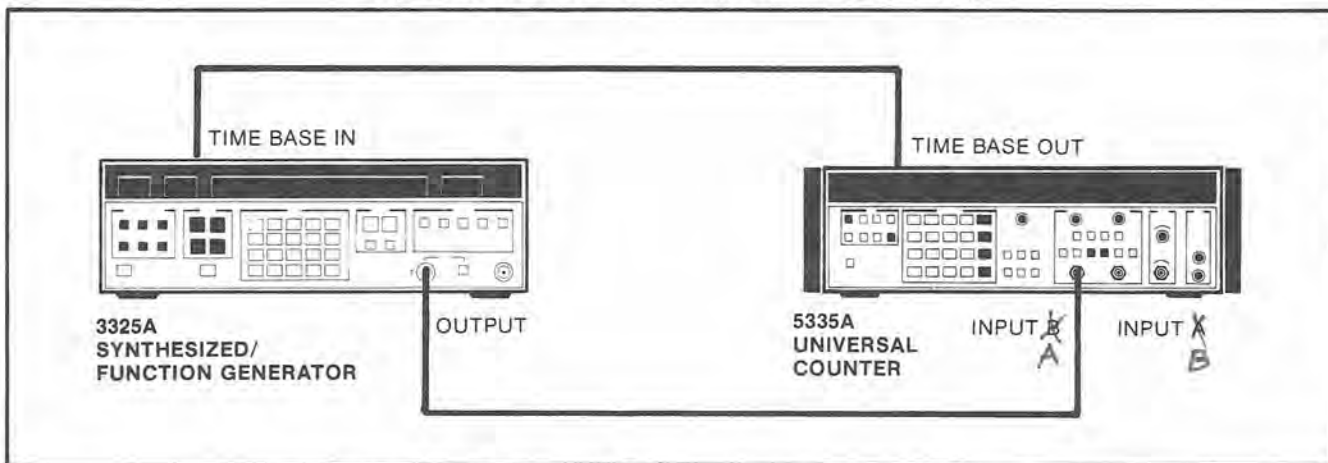

Figure 4-13. Time Interval and Inverse Time Interval Test Setup

- c. Set HP 3325A to 5 MHz at 100 mV rms square wave. The 5335A should read 100 ns \pm 5 ns.
- d. Record results on test card (PASS/FAIL).
- e. Set the HP 5335A for the INVERSE TIME INTERVAL (1/TIME A \rightarrow B) function. Verify that the counter displays: 10.0 +6 \pm 0.5 +6.
- f. Record results on test card (PASS/FAIL).

4-70. Pulse Width A and Pulse Width B Procedure IX

4-71. SPECIFICATIONS: 5 ns to 10⁺⁷ seconds.

4-72. DESCRIPTION: A Pulse Generator provides a pulse waveform which is applied to the 5335A INPUT A (INPUT B). The counter is set to its PULSE WIDTH A and PULSE WIDTH B functions. The 5335A should display the proper count.

4-73. Perform the following steps to use the PULSE WIDTH test:

- a. Connect the HP 8082 Pulse Generator to the HP 5335A INPUT A as shown in Figure 4-14.
- b. Set the 5335A front panel controls as follows:

FUNCTION PULSE A
 MATH Off (LEDs off)
 STATISTICS Off (LEDs off)
 GATE MODE MIN (LED ON)
 CYCLE NORM

INPUT (Channel A and B):

1 M Ω /50 Ω 50 Ω (ON)
 X10/X1 ATTN X1 (OUT/OFF)
 AC/DC DC (OUT/OFF)
 Slope POS (OUT/OFF)
 Trigger Level PRESET
 FILTER (Option 040) OFF
 AUTO TRIG IN (ON)
 COM A OUT (OFF)

- c. Using the HP 1743A oscilloscope Delta Time function, set HP 8082A to output a 1V, 4-microsecond pulse, with a period of 10 μ s, at the fastest transition times (approximately 1 ns). The 5335A should display 4.000 μ s \pm 5 ns.
- d. Record results on test card (PASS/FAIL).
- e. Set the 5335A channel A slope to NEG (IN/ON). Verify that the counter displays 6.000 μ s \pm 5 ns.
- f. Record result on test card (PASS/FAIL).
- g. Press: SCALE, SMOOTH, 2, 0, ENTER. This will enable special function PULSE B. Reconnect the HP 8082A to the 5335A INPUT B.
- h. Verify that the 5335A displays 6.000 μ s \pm 5 ns.
- i. Record result on test card (PASS/FAIL).
- j. Set the 5335A channel A slope to POS (OUT/OFF). Verify that the counter displays 4.000 μ s \pm 5 ns.
- k. Record result on test card (PASS/FAIL).

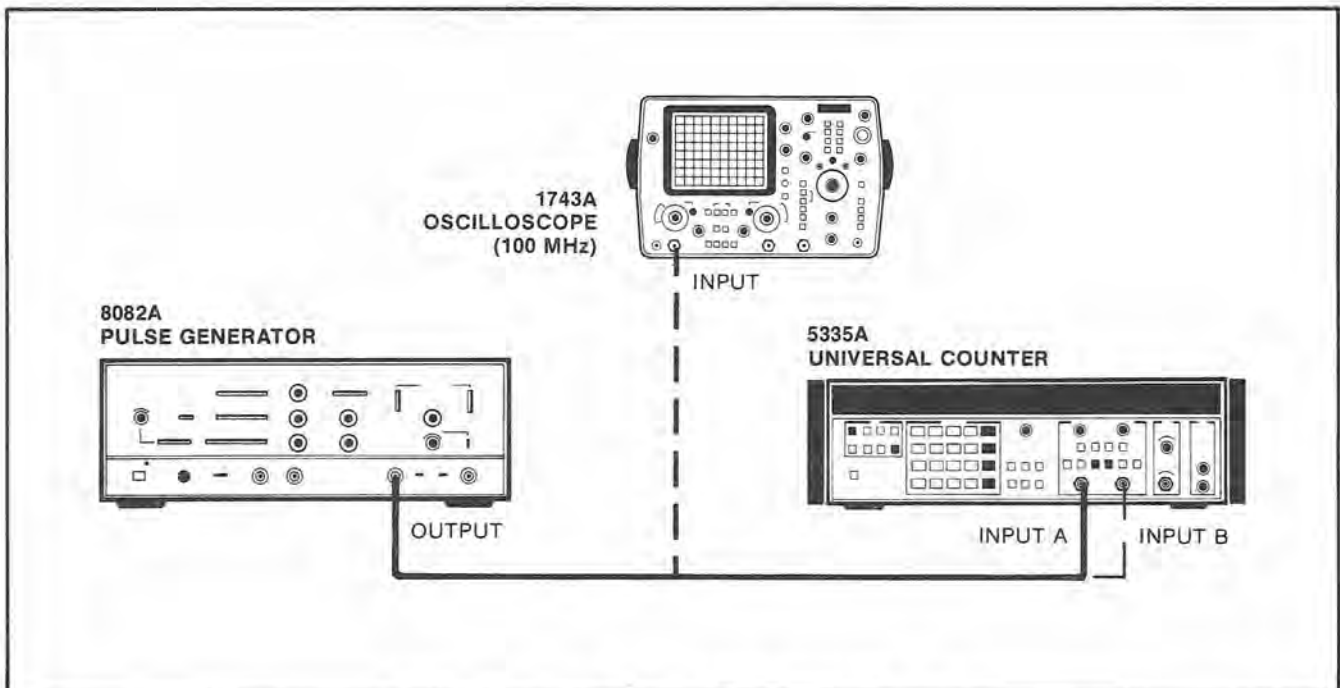

Figure 4-14. Pulse Width A and Pulse Width B Test Setup

4-74. Rise and Fall Time A Test Procedure X

4-75. Specifications:

- a. Pulse transition range: 20 ns to 10 ms.
- b. Minimum pulse height: 500 mV peak-peak.
- c. Minimum pulse width at peak of signal: 20 ns.
- d. Duty cycle range: 20% to 80%.
- e. Range: 50 Hz to 25 MHz (50% duty cycle).

4-76. DESCRIPTION: A Pulse Generator provides a trapezoidal signal, which is applied to the 5335A INPUT A. The counter is set to measure the RISE and FALL TIME A of the signal. The 5335A should display the proper count.

NOTE

The waveform used in this test is also used in the SLEW RATE A test.

4-77. Perform the following steps to use the RISE and FALL A test:

- a. Connect the 8082A Pulse Generator to the 5335A INPUT A as shown in Figure 4-15.

- b. Set the 5335A front panel controls as follows:

FUNCTION RISE/FALL A
 MATH Off (LEDs off)
 STATISTICS Off (LEDs off)
 CYCLE NORM
 INPUT (Channel A and B):
 1 M Ω /50 Ω 50 Ω (ON)
 X10/X1 ATTN X1 (OUT/OFF)
 AC/DC DC (OUT/OFF)
 Channel A Slope POS (OUT/OFF)
 FILTER (Option 040) OFF

- c. Using the HP 1743A oscilloscope Delta Time function, set HP 8082A to output a pulse as shown in Figure 4-16. Verify that the 5335A displays 400 ns \pm 82 ns.

- d. Set the 5335A for the FALL TIME A function by setting channel A slope to NEG (IN/ON). Verify that the counter displays 400 ns \pm 82 ns.

- e. Record results on test card (PASS/FAIL).

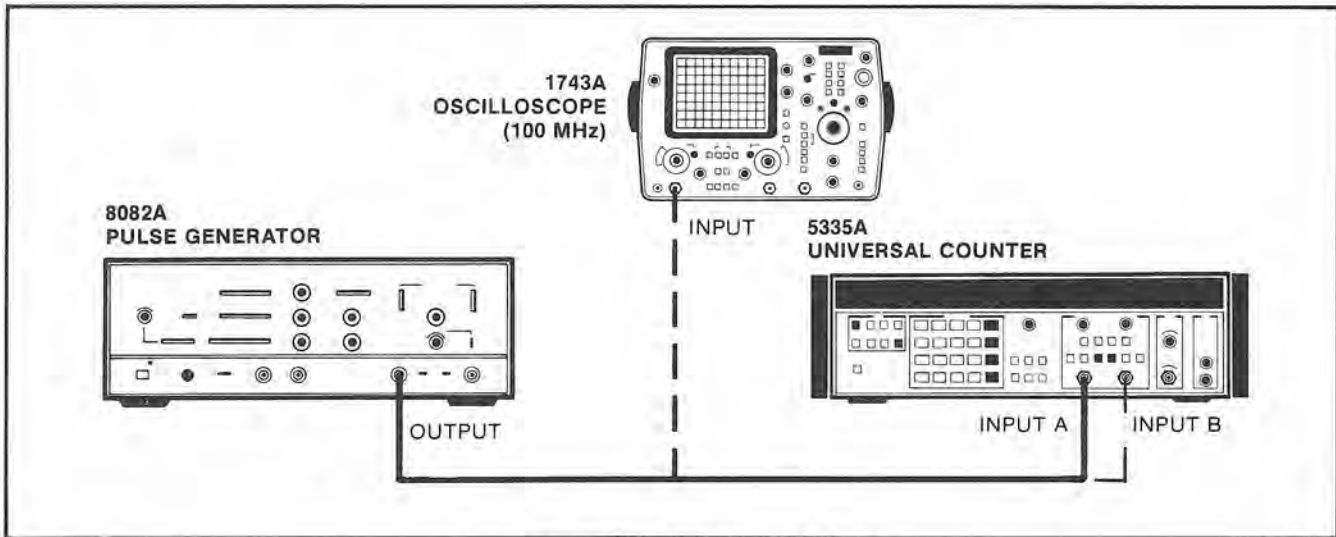

Figure 4-15. Rise and Fall Time A Test Setup

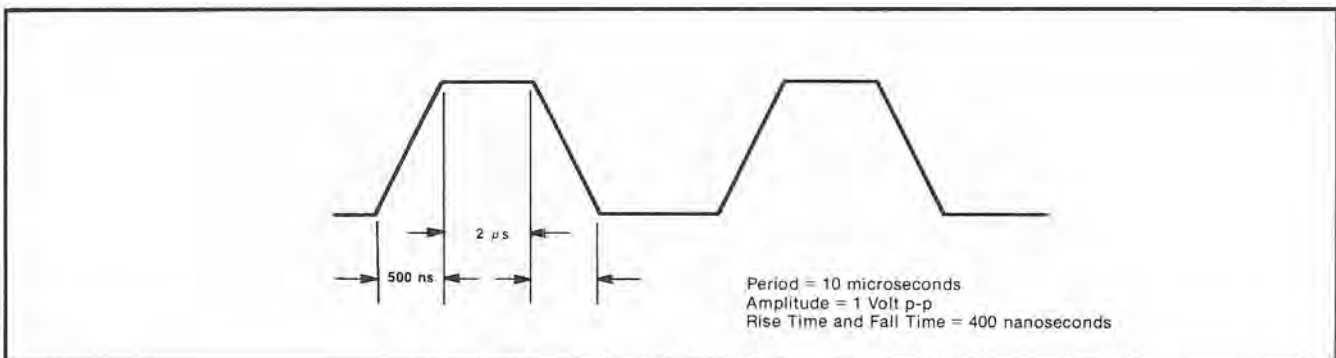

Figure 4-16. Rise and Fall Time A Test Waveform

4-78. Slew Rate A Test Procedure XI

4-79. Specifications:

- a. 50 V/s to 10^{+8} V/s.
- b. Range: 50 Hz to 25 MHz (50% duty cycle).
- c. Minimum pulse height: 500 mV peak-to-peak.
- d. Minimum pulse width at peak of signal: 20 ns.
- e. Duty cycle range: 20% to 80%

4-80. DESCRIPTION: A Pulse Generator provides a trapezoidal waveform (same as for RISE/FALL TIME A), which is applied to the 5335A INPUT A. The counter is set to its SLEW RATE A function. The 5335A should display the proper count.

4-81. Perform the following steps to use the SLEW RATE test:

- a. Repeat steps a and c from RISE/FALL TIME A test.
- b. Set the 5335A front panel controls as follows:

```

FUNCTION ..... SLEW RATE A
MATH ..... Off (LEDs off)
STATISTICS ..... Off (LEDs off)
CYCLE ..... NORM
INPUT (Channel A and B):
  1 MΩ/50Ω ..... 50Ω (ON)
  X10/X1 ATTN ..... X1 (OUT/OFF)
  AC/DC ..... DC (OUT/OFF)
  Channel A Slope ... POS (OUT/OFF)
  FILTER (Option 040) ..... OFF
    
```

- c. Verify that the 5335A displays $2.00 \times 10^{+6}$ V/s $\pm 0.65 \times 10^{+6}$ V/s.
- d. Record results on test card (PASS/FAIL).

4-82. Phase A rel B Test Procedure XII

4-83. Specifications:

- a. -180° to 360° (Range Hold OFF).
- b. 0° to 360° (Range Hold ON).
- c. Frequency Range: 30 Hz to 1 MHz.

4-84. DESCRIPTION: A Pulse Generator with complementary outputs drives both channels A and B of the 5335A under test. The counter is set to the "PHASE A rel B" function and the channels are set in SEP mode. The 5335A should display the phase relationship between the two signals.

4-85. Perform the following steps to use the PHASE A rel B test:

- a. Set the 5335A front panel controls as follows:

```

FUNCTION ..... PHASE A rel B
MATH ..... Off (LEDs off)
STATISTICS ..... Off (LEDs off)
CYCLE ..... NORM
INPUT (Channel A and B):
  1 MΩ/50Ω ..... 50Ω (ON)
  X10/X1 ATTN ..... X1 (OUT/OFF)
  AC/DC ..... DC (OUT/OFF)
  Slope ..... POS (OUT/OFF)
  FILTER (Option 040) ..... OFF
  COM A ..... OUT (OFF)
    
```

b. Connect the 8082A Pulse Generator to the 5335A INPUT A and B as shown in Figure 4-17.

c. Set HP 8082A to output a $1 \mu\text{s}$ square wave at 1-volt peak-to-peak. Set the generator to output signals with the fastest transition time (approximately 1 ns). The 5335A should display $180^\circ \pm 1.5^\circ$.

- d. Record result on test card (PASS/FAIL).

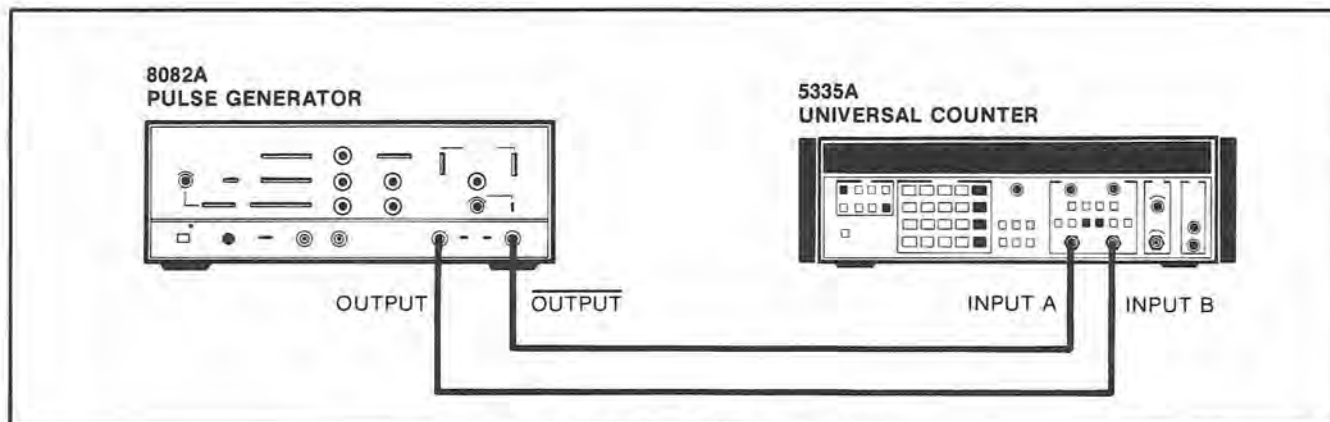

Figure 4-17. Phase A rel B Test Set-Up

4-86. DVM (Option 020) Test Procedure XIII

4-87. SPECIFICATION: The 5335A will measure input voltages in the $\pm 1000V$ range. Option 020 is an autoranging, autopolarity, floating DVM, based on a voltage-to-frequency conversion design.

4-88. DESCRIPTION: A precision power supply is connected to the 5335A's DVM input. Several voltages are selected to cover the voltage range of the DVM. The 5335A should display the correct reading.

4-89. Perform the following steps to use the DVM test:

a. Set the 5335A front panel controls as follows:

```

FUNCTION ..... GATE TIME
MATH ..... Off (LEDs off)
STATISTICS ..... Off (LEDs off)
CYCLE ..... NORM
GATE MODE ..... NORM
GATE ADJ ..... (150  $\pm$ 25) ms
    
```

b. Apply power to the 5335A, enable the volts function, then allow a 20-minute warm-up.

c. Place a jumper across the DVM's input connectors and verify that counter displays $0V \pm 600 \mu V$.

d. Record result on test card (PASS/FAIL).

e. Remove jumper from DVM input terminals.

f. Connect power supply to the 5335A DVM input terminals as shown in Figure 4-18.

g. Set DC Standard for 4.0000 volts. The counter should display $4.000V \pm 3.8 mV$. Repeat for -4.0000 volts.

h. Record results on test card (PASS/FAIL).

i. Set DC Standard for 40.000 volts. The counter should display $40.00V \pm 38 mV$. Repeat for -40.000 volts.

j. Record results on test card (PASS/FAIL).

k. SET DC Standard for 400.00 volts. The 5335A should display $400.0V \pm 380 mV$. Repeat for -400.00 volts.

l. Record results on test card (PASS/FAIL).

4-90. Channel C (Option 030) Test Procedure XIV

4-91. SPECIFICATIONS: 150 MHz to 1.3 GHz, pre-scaled by 20.

a. 10 mV rms sine wave ($-27 dBm$) to 1 GHz.

b. 100 mV rms sine wave ($-7 dBm$) to 1.3 GHz.

4-92. DESCRIPTION: A signal generator is connected through a power splitter to the 5335A Channel C input and to a Power Meter. The signal generator is varied over the frequency range, maintaining the specified signal level. The counter should display the correct frequencies.

4-93. Perform the following steps to use the Channel C test:

a. Set the 5335A front panel controls as follows:

```

FUNCTION ..... GATE TIME
MATH ..... Off (LEDs off)
STATISTICS ..... Off (LEDs off)
CYCLE ..... NORM
GATE MODE ..... NORM
GATE TIME ..... to 2 s  $\pm$ 0.1 s
INPUT C Sensitivity ..... MAX (CW)
    
```

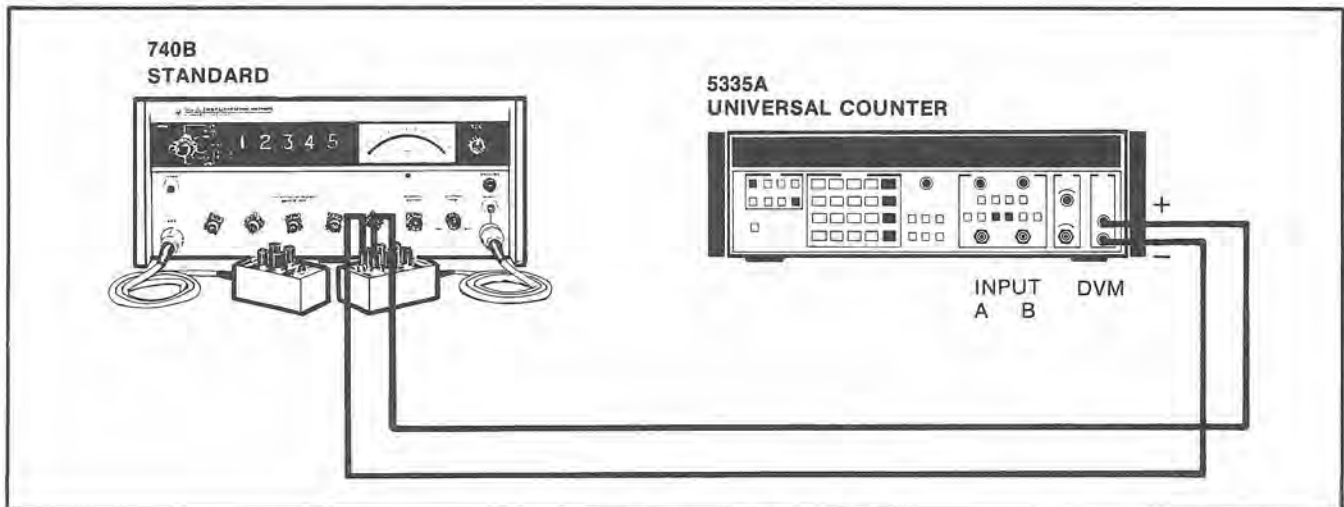

Figure 4-18. DVM Test Set-Up (Option 020)

b. Apply power to the 5335A, enable the FREQ C function, then allow a 5-minute warm-up.

150 MHz to 1 GHz

c. Connect the signal generator and the power meter to the 5335A INPUT C as shown in Figure 4-19.

d. Set the signal generator output such that the power meter reads -21 dBm at 150 MHz. Increase the frequency of the signal generator while maintaining a -21 dBm reading on the power meter, and verify that the 5335A displays the proper frequency from 150 MHz to 1 GHz.

e. Measure actual sensitivity by decreasing the 86603A level until the 5335A gives an unstable display at these frequencies: 150 MHz, 500 MHz, 800 MHz, 1000 MHz.

f. Record results on test card (VALUE).

1 GHz to 1.3 GHz

g. Set the 86603A for an output at 1 GHz at -1 dBm, as read on the power meter. Increase the frequency of the 8660C while maintaining a -1 dBm reading on the power meter, and verify that the 5335A displays the proper frequency from 1 GHz to 1.3 GHz.

h. Measure actual sensitivity by decreasing the 86603A level until the 5335A gives an unstable display at these frequencies: 1.1 GHz, 1.3 GHz.

i. Record results on test card (VALUE).

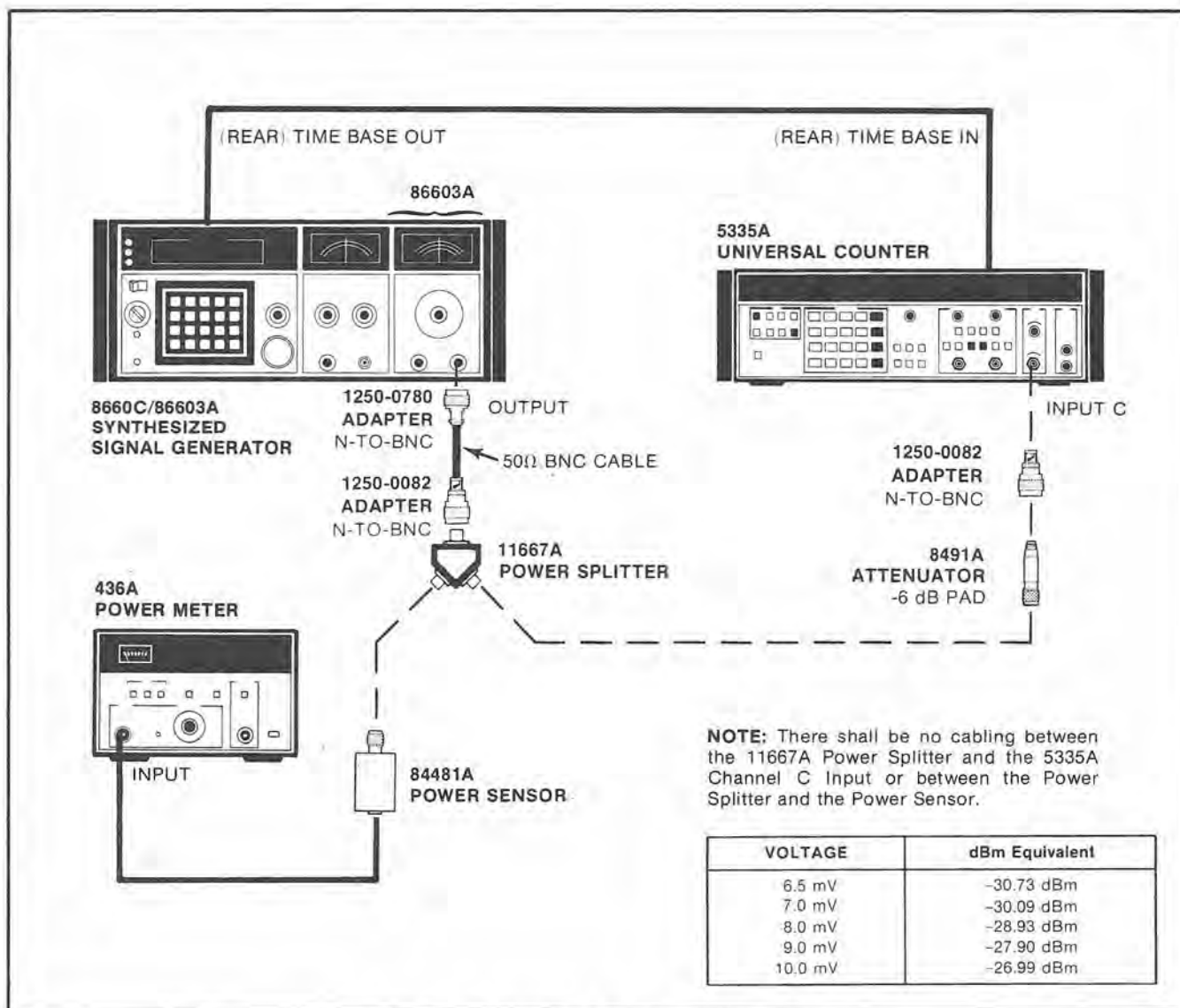

Figure 4-19. Channel C Test Set-Up (Option 030)

4-94. HP-IB VERIFICATION PROGRAM USING THE 9825A CONTROLLER

4-95. The 9825A program listed in *Table 4-4* exercises the 5335A through various operating modes via the HP-IB interface. It is also designed to test Option 020 (DVM), Option 030 (Channel C), and Option 040 (Programmable Input). If the 5335A successfully completes all phases of the verification program, then there is a high probability that the HP-IB Interface (A7 and A14 assemblies), and the counter are working properly.

4-96. To perform the verification, set up the 5335A as shown in *Figure 4-20*, and set the 5335A rear panel address switches to address 28.

4-97. The program listed in *Table 4-4* may be keyed into the 9825A or loaded from an HP-IB Verification Cassette, HP Part Number 59300-10001 (revision L or later), which also contains HP-IB verification programs for the 59300 series of instruments. To run the program on the cassette, insert the cassette into the 9825A, load file 0 (type ldp0), and press EXECUTE. Enter "5335" when the instrument model number is requested, and press CONTINUE. Enter select code "728" when the select code is requested, and press CONTINUE. The 9825A will then load the 5335A verification program into memory.

4-98. Set up the 5335A front panel switches as described in the printout, and press CONTINUE. Follow the directions described on the printout to proceed with the HP-IB verification.

4-99. The program goes through 15 check points for the standard instrument, and an additional 3 check

points for Options 020, 030, and 040. The information in *Table 4-3* shows what occurs during each test and what should be observed by the operator if the test has been successfully completed. At the conclusion of each test, the program stops and displays the current check point. To advance to the next test, simply press CONTINUE. If it is desired to repeat a test, key in "cont" and the check point number, and press EXECUTE (e.g., to repeat test 3, key in . . . cont "3"). To go on to the next test after looping, press CONTINUE.

4-100. At the end of the HP-IB Verification Program, the controller will ask if you want to repeat one of the tests, Answer "1" for YES and "0" for NO, then push CONTINUE. If YES, the controller then asks which test is to be repeated. Enter the appropriate number for the test needed (as indicated on the printout), then press CONTINUE. The selected test will be repeated. At the end of that particular test the question whether or not to repeat a test is asked again. If you want to repeat the same test press CONTINUE three times. If not, press CONTINUE, enter 0 and press CONTINUE again.

NOTE

If the last test performed was TEST #14, Front Panel Switch Test, you will need to turn the 5335A power OFF then ON in order to return the counter to local control.

4-101. If it is desired to test a specific check point within the HP-IB Verification Program, load the tape or key in the program in the normal manner. Proceed until the controller prints the set-up information. Then key in . . . cont "rpt" . . . and press EXECUTE. The program will advance to the end and the controller

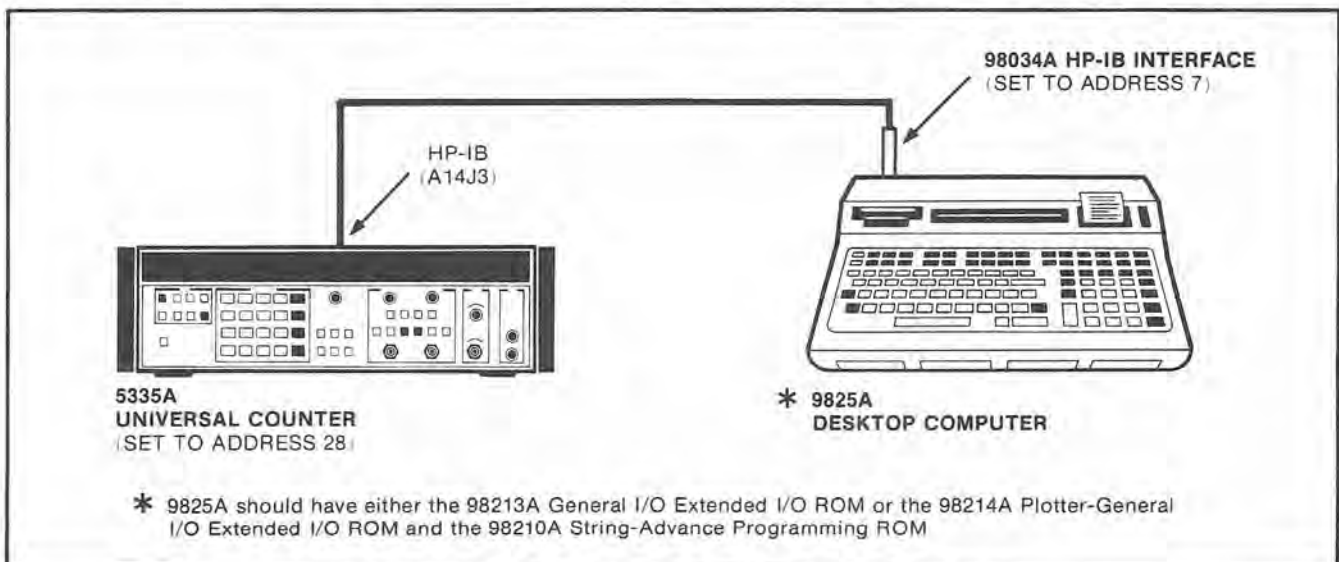
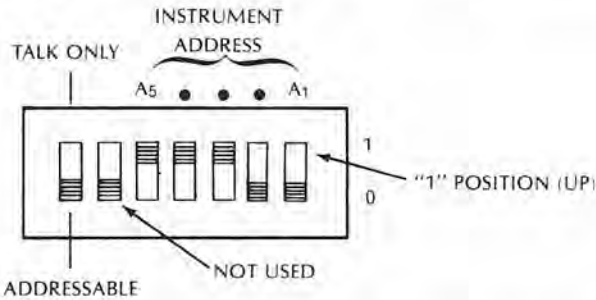

Figure 4-20. HP-IB Verification Set-Up (9825A Controller)

will ask if you want to repeat one of the tests. Then use the method described in paragraph 4-99.

4-102. To perform the HP-IB verification proceed as follows:

- a. Set-up the 5335A and the 9825A as shown in Figure 4-20.
- b. Set the 5335A rear panel ADDRESS switch (A14S1) as follows:



- c. Key the program listed in Table 4-4 into the 9825A, or insert cassette, HP P/N 59300-10001 (revision L or later).
- d. Load and run file 0. (key in ldp0); press EXECUTE.
- e. Key in the model number of the instrument to be tested (i.e., 5335); press CONTINUE.
- f. Key in select code 728; press CONTINUE.
- g. Set-up the 5335A as described in the printout and press CONTINUE.
- h. Always press CONTINUE to advance the program.

Table 4-3. 9825A Verification Program Printout

```

*****

5335A UNIVERSAL
COUNTER HP-IB
Verification
Program.

*****

CONNECT:
Time Base Out
from rear panel
to INPUT A.
    
```

} Set-up instructions for the 5335A front panel.

Table 4-3. 9825A Verification Program Printout (Continued)

| | |
|---|---|
| <pre>----- CHECK POINT 1 5335A POWER-UP CHECK. Turn 5335A power OFF then ON. VERIFY: *RED LED 'STBY' lamp is OFF *All display ennunciator lamps turn ON momentarily (excluding 'STBY' and trigger lamps) *Display shows the selected HP-IB address for about 1 sec *Display then shows '0' momentarily; Function FREQ A and Hz annun. lamps are ON *Then 5335A will display: 10. 000 000 +6 with 'Hz' LED ON; 'GATE', 'A' and 'B' Trigger lites flashing.</pre> | <p>Checks the 5335A power-up conditions and performs basic Frequency A measurement.</p> |
| <pre>----- CHECK POINT 2 Program sends 5335A 'listen' address. Verify: Display is same as above except 'LISTEN' and 'REMOTE' ennunciators are lit.</pre> | <p>Set the 5335A in the "REMOTE" and "LISTEN" state.</p> |

Table 4-3. 9825A Verification Program Printout (Continued)

| | |
|--|---|
| <pre>----- CHECK POINT 3 SETUP: both chans 50 chans, X1, DC, all slopes=pos, levels = preset, sep/com A=com A, Auto Trig. ON, Gate Adj.= full ccw. Program sends 5335A talk address. Verify: Display is same as CHECK POINT 1 except 'TALK' and 'REMOTE' ennunciators are lit. OUTPUT test: Verify: Same reading on calculator display as on 5335A display. (Available for 10 seconds.)</pre> | <p>} Addresses the 5335A to make a FREQ A measurement and to output the data.</p> |
| <pre>----- CHECK POINT 4 Press LOC/RESET on 5335A. Verify: 'REMOTE' LED goes out.</pre> | <p>} Operator verification of proper operation of the front panel LOC/REM function. (No remote codes sent.)</p> |

Table 4-3. 9825A Verification Program Printout (Continued)

| | |
|--|---|
| <p>----- CHECK POINT 5 Program sets 5335A in the 'local-lockout' mode. Press LOC/RESET on the 5335A and verify that 'REMOTE' LED stays ON.</p> | <p>} Programs the 5335A to go-to-remote and activates counters local-lockout (LLO).</p> |
| <p>----- CHECK POINT 6 Program sets 5335A in the WAIT and SERVICE REQUEST mode. Verify that the following LEDs are lit during five (5) measurements: * TALK * LISTEN * SRQ * REMOTE</p> | <p>} The 5335A is programmed to wait until it is addressed to talk before making another measurement. At the end of the measurements the program will "beep".</p> |

Table 4-3. 9825A Verification Program Printout (Continued)

```
-----
CHECK POINT 7
TEACH-LEARN Test
```

```
Verify that the
5335A displays
11. 224 49 +15
Hz.
```

```
5335A will teach
the 9825A the
front panel
setup.
```

```
Verify that the
5335A displays
100. 000 00 -9
with 'S' and
Function PER A
lites ON, and
'GATE' LED fla-
shing.
```

```
5335A will learn
from 9825A.
Verify that the
5335A displays
11. 224 49 +15
Hz.
```

The 5335A is first programmed for a particular setting, then the counter will teach the 9825A the front panel setup. When CONTINUE is pressed, the 5335 is set up for a Period A measurement.

When CONTINUE is pressed again, the 5335A will learn from the 9825A.

Table 4-3. 9825A Verification Program Printout (Continued)

| | |
|---|---|
| <pre>----- CHECK POINT 8 FREQ B Test. SETUP: Connect TBO from rear panel to INPUT B. VERIFY: *5335A displays 10. 000 000 +6 *'Hz' lamp ON *'GATE' lamp flashing *'TALK' and 'REMOTE' lamps are lit *ALL FUNCTION lamps OFF *'B' trigger light flashing.</pre> | <p>The 5335A is set up and programmed for a Frequency B measurement.</p> |
| <pre>----- CHECK POINT 9 TRIG LEVEL Test. Program sets Trig Lvl funct. VERIFY: Trigger Level A= +0.00V (actual) Trigger Level B= +0.00V (actual)</pre> | <p>The 5335A is set up to measure and display Channel A and B trigger levels.</p> |

Table 4-3. 9825A Verification Program Printout (Continued)

CHECK POINT 10
GATE TIME Test.

GATE ADJ. Normal
Range test.
Vary 'GATE ADJ.'
pot and verify
change in Gate
Time displayed;
NOMINALLY;
between 20
milliseconds
and 4 seconds.

} Both gate time ranges of the 5335A are programmed.

GATE ADJ. Fast
Range test.
Vary 'GATE ADJ.'
pot and verify
change in Gate
Time displayed;
NOMINALLY;
between 100
microseconds
and 20 milli-
seconds.

Table 4-3. 9825A Verification Program Printout (Continued)

CHECK POINT 11
RISE/FALL TIME
Test.

SETUP:
Connect TBO from
rear panel to
INPUT A.

RISE TIME test.

VERIFY:

*RISE/FALL A

lamp is ON

*5335A displays

approximately

30 nanoseconds

*Gate Mode MIN

lamp is ON

*'GATE' lamp

flashing

*'A' and 'B'

trigger lamps

flashing

*'TALK'

lamp ON

*'REMOTE'

lamp ON.

The 5335A is exercised in the Rise and Fall Time mode.

FALL TIME test.

Verify: 5335A

display is about

the same as for

Rise Time test.

Table 4-3. 9825A Verification Program Printout (Continued)

```

-----
CHECK POINT 12
OVERFLOW Test.

Verify ONLY
lamps lit during
the 11 seconds
wait period:
#FREQ A
#GATE MODE
Manual
*'Hz'
*'GATE'
*'LISTEN'
*'REMOTE'
*'A' trigger
lamp (flash)
5335A Display:
'0.'

Verify:
Same as above
except---
#5335A displays
+10.0000000002 +6
(actual)
*'LISTEN'
lamp is OFF
*'GATE'
lamp is OFF
*'TALK'
lamp is ON.

```

CHECK POINT 12 exercises the "gate open" and "gate closed" functions.

Table 4-3. 9825A Verification Program Printout (Continued)

```
-----  
CHECK POINT 13  
TIME INTERVAL  
Test.
```

```
VERIFY:  
*TIME A→B  
  lamp is ON  
*5335A displays  
  approximately  
  50 nanoseconds  
*Gate Mode MIN  
  lamp is ON  
*'GATE' lamp  
  flashing  
*'A' and 'B'  
  trigger lamps  
  flashing  
*'TALK'  
  lamp ON  
*'REMOTE'  
  lamp ON.
```

The 5335A is programmed in the TIME A→B function.

```
INVERSE TIME  
INTERVAL Test.  
VERIFY:  
*1/TIME A→B  
  lamp is ON  
*5335A displays  
  approximately  
  20.  +6  
*Gate Mode MIN  
  lamp is ON  
*'GATE' lamp  
  flashing  
*'A' and 'B'  
  trigger lamps  
  flashing  
*'TALK'  
  lamp ON  
*'REMOTE'  
  lamp ON.
```

The INVERSE TIME A→B is exercised; the actual displayed value may differ.

Table 4-3. 9825A Verification Program Printout (Continued)

 CHECK POINT 14
 FRONT PANEL
 Switch Test.

Press each
 momentary type
 key on the 5335A
 front panel,
 beginning with
 upper left key
 (MATH DISABLE)
 and go down each
 column.

Press CONTINUE
 to perform test.

A number will be
 displayed when
 a key is pressed
 corresponding to
 FIGURE A.

} Programs the 5335A for Diagnostic #17.

Figure A

| | | | | | | | | | | | | | | | | | |
|-------------------|----|----|----|-----------------|----|----|----|----|------------------|----|----|----|----|----|----|----|----|
| MATH | | | | FUNCTION | | | | | INPUT | | | | | | | | |
| 01 | 03 | 05 | 07 | 09 | 13 | 17 | 21 | 25 | 35 | 37 | 39 | 41 | 43 | 45 | | | |
| STATISTICS | | | | 10 | 14 | 18 | 22 | 26 | GATE MODE | | | | | | | | |
| 02 | 04 | 06 | 08 | 11 | 15 | 19 | 23 | 27 | 29 | 31 | 33 | 36 | 38 | 40 | 42 | 44 | 46 |
| | | | | 12 | 16 | 20 | 24 | 28 | CYCLE | | | | | | | | |
| | | | | | | | | | 30 | 32 | 34 | | | | | | |

Table 4-3. 9825A Verification Program Printout (Continued)

| | | |
|--|---|--|
| <pre>----- CHECK POINT 15 FRONT END Test.</pre> | <pre>VERIFY: *All display annunciator lamps turn ON for about 5 seconds *5335A displays 'FE PASS' for about 15 seconds *Then 5335A will display: the voltages at A2U4(2,12,10): NOMINAL values are: 5. 000 00 V 3. 100 00 V -5. 200 00 V</pre> | <p>The 5335A is programmed to fully test the front end by connecting the Time Base Out to INPUT A.</p> |
| <pre>----- CHECK POINT 16 OPTION 020 Test.</pre> | <pre>SETUP: Connect Trigger Level 'A' from rear panel to DVM input jack; set PRESET 'A' off; but in CCW position. Verify that 5335A displays approximately -5.XXX Volts. Rotate 'A' level control CW and check that display is about the same as before with opposite sign.</pre> | <p>The 5335A is set up to verify the proper operation of the DVM, Option .020.</p> |

Table 4-3. 9825A Verification Program Printout (Continued)

| | |
|---|--|
| <pre>----- CHECK POINT 17 OPTION 030 Test.</pre> | <p>Programs and verifies the correct operation of the Channel C, Option 030.</p> |
| <pre>SETUP: Connect an 86603A to 5335A 'C' Input and 8660C TBO to 5335A Time Base In.</pre> | |
| <pre>Verify that 5335A displays the frequency of the 8660C. (150MHz→1.3GHz)</pre> | |
| <pre>----- CHECK POINT 18 OPTION 040 Test.</pre> | <p>Exercises Option 040 Front End Input momentary switches.</p> |
| <pre>VERIFY: All INPUT momen- tary switches are activated & de-activated.</pre> | |
| <pre>DAC Test.</pre> | <p>Performs a functional test on the 5335A Channel A and B DACS.</p> |
| <pre>Pass DAC Test.</pre> | |
| <pre>*****</pre> | |
| <pre>END OF 5335A HP-IB TEST.</pre> | |
| <pre>*****</pre> | |

Table 4-4. 5335A HP-IB Verification Program Listing (9825A Controller)

```
0: "5335A HP-IB VERIFICATION PROGRAM -- REV. B":
1:
2: dim A$(32),B$(21),C$(16),D$(16),E$(40),F$(21),A(30)
3: "CHECK POINT --Press CONTINUE."->A$
4: "-----">D$;"*****">C$
5: "Press CONTINUE to perform test."->E$;0->X->Y
6: "code":ent "Select code ?",S
7: if S=721;dsp "Error: calculator address";wait 2000;gto "code"
8: if S>730;dsp "Out of address range -> high";wait 2000;gto "code"
9: if S<700;dsp "Out of address range -> low";wait 2000;gto "code"
10: dev "sj",S;prt C$;spc ;prt "5335A UNIVERSAL","COUNTFF HP-IB"
11: prt "Verification","Program.";spc ;prt C$;spc 2
12: prt "CONNECT:","Time Base Out","from rear panel","to INPUT A.";spc 3
13: dsp A$(18);stp
14: "1":dsp A$(1,11)," 1"
15: prt D$;wrt 16,A$(1,13),"1"
16: prt "5335A POWER-UP","CHECK.";spc
17: prt "Turn 5335A power","OFF then ON.";spc 2;dsp A$(18);sto
18: prt "VERIFY:","*RED LED 'STBY'"
19: prt " lamp is OFF","*All display"," annunciator"," lamps turn ON"
20: prt " momentarily"," (excluding"," 'STBY' and"," trigger lamps)"
21: prt "*Display shows"," the selected"," HP-IB address"
22: prt " for about 1 sec","*Display then"," shows '0'," " momentarily;"
23: prt " Function FREQ A"," and Hz annun."
24: prt " lamps are ON","*Then 5335A will"," display:"
25: prt " 10. 00C 000 +6"," with 'Hz' LED"," ON; 'GATE', 'A'"
26: prt " and 'B' Trigger"," lites flashing.";spc 2
27: dsp A$(1,11)," 1",A$(16);sto
28: if X=1;gto "rpt"
29: "2":dsp A$(1,11)," 2"
30: prt D$;wrt 16,A$(1,13),"2"
31: prt "Program sends","5335A 'listen'," "address.";spc
32: prt "Verify:","Display is same","as above except"," 'LISTEN' and"
33: prt "'REMOTE'," "annunciators","are lit.";spc 2
34: wrt "sj"
35: dsp A$(1,11)," 2",A$(16);sto
36: if X=1;gto "rpt"
37: "3":dsp A$(1,11)," 3";lcl "sj"
38: prt D$;wrt 16,A$(1,13),"3";spc 2
39: prt "SETUP:","both chans","50 ohms,X1,DC","all slopes=pos,"
40: prt "levels = preset","sep/com A=com A","Auto Trig. ON,"
41: prt "Gate Adj.=","full ccw.";spc 2;dsp E$;stp
42: prt "Program sends","5335A talk","address. Verify:"
43: prt "Display is same","as CHECK POINT 1"
44: prt "except 'TALK'," "and 'REMOTE'," "annunciators","are lit.";spc 2
45: wrt "sj","in";red "sj",B$;dsp A$(1,11)," 3",A$(16);stp
46: prt "OUTPUT test:","Verify:","Same reading on","calculator","display"
47: prt "as on 5335A","display.," "(Available for","10 seconds.)";spc 2
48: dsp E$;stp
49: for I=1 to 30;red "sj",B$;dsp B$;next I;beep
50: dsp A$(1,11)," 3",A$(16);stp
51: if X=1;gto "rpt"
52: "4":dsp A$(1,11)," 4"
53: prt D$;wrt 16,A$(1,13),"4"
```

Table 4-4. 5335A HP-IB Verification Program Listing (9825A Controller) (Continued)

```

54: prt "Press LOC/RESFT", "on 5335A.", "Verify: 'REMOTE'", "LED goes out."
55: spc 2
56: dsp A$[1,11], " 4", A$[16];stp
57: if X=1;gto "rpt"
58: "5":dsp A$[1,11], " 5"
59: prt D$;wrt 16,A$[1,13], "5"
60: prt "Program sets", "5335A in the", "'local-lockout'", "mode."
61: prt "Press LOC/RESET", "on the 5335A and", "verify that", "'REMOTE' LED"
62: prt "stays ON.";spc 2
63: wrt "sj";llo 7
64: dsp A$[1,11], " 5", A$[16];stp
65: if X=1;gto "rpt"
66: "6":dsp A$[1,11], " 6"
67: prt D$;wrt 16,A$[1,13], "6"
68: prt "Program sets", "5335A in the", "WAIT and", "SERVICE REQUEST", "mode."
69: sprc ;prt "Verify that the", "following LEDs", "are lit during"
70: prt "five (5)", "measurements:"
71: prt "* TALK", "* LISTEN", "* SRQ", "* REMOTE";spc 2;stp ;dsp E$
72: lcl "sj";wrt "sj", "walsrl";0+I
73: oni 7, "SRQ"
74: eir 7
75: gto -1;if I>5;gto 81
76: "SRQ":for I=1 to 5
77: if hit(6,rds("sj"));red "sj",R$;dsp B$
78: wrt "sj", "re";wait 1000
79: next I
80: iret
81: dsp A$[1,11], " 6", A$[16];beep;stp
82: if X=1;gto "rpt"
83: "7":dsp A$[1,11], " 7"
84: prt D$;wrt 16,A$[1,13], "7"
85: prt "TEACH-LEARN Test";spc
86: prt "Verify that the", "5335A displays", "11. 224 49 +15 Hz.";spc 2
87: dsp F$;stp
88: rem "sj";wrt "sj", "fulms1122448800"
89: prt "5335A will teach", "the 9825A the", "front panel", "setup.";spc 2
90: wrt "sj", "pd"
91: for I=1 to 30
92: rdb("sj")>A[I];next I
93: gto -1;if A[24]=17 and A[25]=34;gto +1
94: gto -2;if A[26]=68 and A[27]=136 and A[28]=0 and A[29]=0;gto +1
95: dsp "5335A + 9825A ", A$[18];0+I;stp
96: prt "Verify that the", "5335A displays", "100. 000 00 -9"
97: prt "with 'S' and", "Function PER A", "lites ON, and"
98: prt "'GATE' LED fla-", "shing."
99: wrt "sj", "fu9";lcl "sj"
100: spc 2;dsp A$[1,11], "7", A$[16];stp
101: prt "5335A will learn", "from 9825A.", "Verify that the"
102: prt "5335A displays", "11. 224 49 +15 Hz.";spc 2
103: wtb "sj", "pb";for I=1 to 30;wtb "sj", A[I];next I;lcl "sj"
104: dsp "9825A + 5335A ", A$[18];stp
105: if X=1;gto "rpt"
106: "8":dsp A$[1,11], " 8"
107: prt D$;wrt 16,A$[1,13], "8"
108: prt "FREQ B Test.";spc ;prt "SETUP:", "Connect TBO from", "rear panel to"
109: prt "INPUT B.";spc 2;dsp A$[1,11], " 8", A$[16];stp
110: prt "VERIFY:", "*5335A displays", " 10. 000 000 +6", "* 'Hz' lamp ON"

```

Table 4-4. 5335A HP-IB Verification Program Listing (9825A Controller) (Continued)

```
111: prt "* 'GATE' lamp", " flashing", "* 'TALK' and"
112: prt " 'REMOTE' lamps", " are lit", "*All FUNCTION", " lamps OFF"
113: prt "* 'B' trigger", " light flashing.";spc 2
114: wrt "sj", "co0ful7";red "sj",B$
115: dsp A$[1,11], " 8",A$[16];stp
116: if X=1;gto "rpt"
117: "9":dsp A$[1,11], " 9"
118: prt D$;wrt 16,A$[1,13], "9"
119: prt "TRIG LEVEL Test.";spc
120: wrt "sj", "ful4";red "sj",B$,F$
121: prt "Program sets", "Trig Lvl funct.";spc ;prt "VERIFY:"
122: wrt 16, "Trigger Level A="
123: wrt 16,B$[11,15], "V (actual)";spc
124: prt "Trigger Level B="
125: wrt 16,F$[11,15], "V (actual)";spc 2
126: dsp A$[1,11], " 9",A$[16];stp
127: if X=1;gto "rpt"
128: "10":dsp A$[1,11], "10";prt D$;wrt 16,A$[1,13], "10"
129: prt "GATE TIME Test.";spc
130: prt "GATE ADJ. Normal", "Range test.", "Vary 'GATE ADJ.'"
131: prt "pot and verify", "change in Gate", "Time displayed", "NOMINALLY,"
132: prt "between 20", "milliseconds", "and 4 seconds.";spc 2
133: wrt "sj", "ful3gm0rh0";dsp A$[1,11], "10",A$[16];red "sj",B$;stp
134: prt "GATE ADJ. Fast", "Range test.", "Vary 'GATE ADJ.'"
135: prt "pot and verify", "change in Gate", "Time displayed", "NOMINALLY,"
136: prt "between 100", "microseconds", "and 20 milli-", "seconds.";spc 2
137: wrt "sj", "ful3gmlrh0";red "sj",B$
138: dsp A$[1,11], "10",A$[16];stp
139: if X=1;gto "rpt"
140: "11":prt D$;wrt 16,A$[1,13], "11";dsp A$[1,11], "11"
141: prt "RISE/FALL TIME", "Test.";spc
142: prt "SETUP:", "Connect TEO from", "rear panel to", "INPUT A.";spc 2
143: dsp E$;stp
144: dsp A$[1,11], "11";prt "RISE TIME test."
145: prt "VERIFY:", "*RISE/FAIL A", " lamp is ON"
146: prt "*5335A displays", " approximately", " 30 nanoseconds"
147: prt "*Gate Mode MIN", " lamp is ON", "* 'GATE' lamp", " flashing"
148: prt "* 'A' and 'B'", " trigger lamps", " flashing", "* 'TALK'"
149: prt " lamp ON", "* 'REMOTE'", " lamp ON.";spc 2
150: wrt "sj", "inful0";wait 3000
151: dsp A$[1,11], "11",A$[16];red "sj",B$;stp
152: dsp A$[1,11], "11";prt "FALL TIME test."
153: prt "Verify: 5335A", "display is about", "the same as for"
154: prt "Rise Time test.";spc 2
155: wrt "sj", "asl";wait 3000
156: dsp A$[1,11], "11",A$[16];red "sj",B$;stp
157: if X=1;gto "rpt"
158: "12":dsp A$[1,11], "12";prt D$;wrt 16,A$[1,13], "12"
159: prt "OVERFLOW Test.";spc
160: prt "Verify ONLY", "lamps lit during", "the 11 seconds", "wait period:"
161: prt "*FREQ A", "*GATE MODE", " Manual", "* 'Hz'", "* 'GATE'", "* 'LISTEN'"
162: prt "* 'REMOTE'", "* 'A' trigger", " lamp (flashing)"
163: prt "5335A Display:", "0.";spc 2
164: dsp E$;stp
165: wrt "sj", "ingm3go";dsp A$[1,11], "12";wait 11000;wrt "sj", "gc"
166: red "sj",B$;beep
167: prt "Verify:", "Same as above", "except---", "*5335A displays"
```

Table 4-4. 5335A HP-IB Verification Program Listing (9825A Controller) (Continued)

```

168: wrt 16,B$[3,15]," +",B$[19];prt " (actual)"
169: prt "* 'LISTEN'," " lamp is OFF","* 'GATE'," " lamp is OFF"
170: prt "* 'TALK'," " lamp is ON.";spc 2
171: dsp A$[1,11],"12",A$[16];stp
172: if X=1;gto "rpt"
173: "13":dsp A$[1,11],"13";prt D$;wrt 16,A$[1,13],"13"
174: prt "TIME INTERVAL","Test.";spc
175: prt "VERIFY:","*TIME A+B"," lamp is ON"
176: prt "*5335A displays"," approximately"," 50 nanoseconds"
177: prt "*Gate Mode MIN"," lamp is ON","* 'GATE' lamp"," flashing"
178: prt "* 'A' and 'B'," " trigger lamps"," flashing","* 'TALK'"
179: prt " lamp ON","* 'REMOTE'," " lamp ON.";spc 2
180: wrt "sj","infu2bslcol";dsp A$[1,11],"13",A$[16];red "sj",B$;stp
181: dsp A$[1,11],"13";prt "INVERSE TIME","INTERVAL Test."
182: prt "VERIFY:","*1/TIME A+B"," lamp is ON"
183: prt "*5335A displays"," approximately"," 20. +6"
184: prt "*Gate Mode MIN"," lamp is ON","* 'GATE' lamp"," flashing"
185: prt "* 'A' and 'B'," " trigger lamps"," flashing","* 'TALK'"
186: prt " lamp ON","* 'REMOTE'," " lamp ON.";spc 2
187: wrt "sj","fu6";dsp A$[1,11],"13",A$[16];red "sj",B$;stp
188: if X=1;gto "rpt"
189: "14":dsp A$[1,11],"14";prt D$;wrt 16,A$[1,13],"14"
190: prt "FRONT PANEL","Switch Test.";spc
191: prt "Press each","momentary type"
192: prt "key on the 5335A","front panel","beginning with"
193: prt "upper left key","(MATH DISABLE)"
194: prt "and go down each","column.";spc 2
195: prt E$;dsp " See FIGURE A !!!!!";spc 2;stp
196: wrt "sj","fu99ms17";wait 100;lcl "sj"
197: prt "A number will be","displayed when"
198: prt "a key is pressed","corresponding to"
199: prt "FIGURE A.";spc 2;dsp A$[1,11],"14",A$[16];stp
200: if X=1;gto "rpt"
201: "15":dsp A$[1,11],"15";prt D$;wrt 16,A$[1,13],"15"
202: prt "FRONT ENC Test.";spc
203: prt "VERIFY:","*All display"," annunciator"," lamps turn ON"
204: prt " for about 5"," seconds","*5335A displays"," 'FE PASS'"
205: prt " for about 15"," seconds","*Then 5335A will"," display:"
206: prt " the voltages at A2U4(2,12,10); NOMINAL values are:"
207: prt " 5. 000 00 V"," 3. 100 00 V"," -5. 200 00 V";spc 2
208: wrt "sj","fu99ms0"
209: dsp A$[1,11],"15",A$[16];stp
210: if X=1;gto "rpt"
211: "16":ent "OPTION 020 (1=Y,0=N) ?",A
212: if A#0 and A#1;gto -1
213: if A=0;gto "17"
214: prt D$;wrt 16,A$[1,13],"16";dsp A$[1,11],"16"
215: prt "OPTION 020 Test.";spc;prt "SETUP:","Connect Trigger"
216: prt "Level 'A' from","rear panel to","DVM input jack;"
217: prt "set PRESET 'A' off, but in CCW position.";spc
218: prt "Verify that","5335A displays","approximately","-5.XXX Volts."
219: spc 2;dsp E$;red "sj",B$;stp
220: wrt "sj","ful5"
221: prt "Rotate 'A' level","control CW ","and check"
222: prt "that display is","about the same","as before with"
223: prt "opposite sign.";spc 2
224: dsp A$[1,11],"16",A$[16];red "sj",B$;stp

```

Table 4-4. 5335A HP-IB Verification Program Listing (9825A Controller) (Continued)

```
225: if X=1;gto "rpt"
226: "17":ent "OPTION 030 (1=Y,0=N) ?",B
227: if B#0 and B#1;gto -1
228: if B=0;gto "18"
229: prt D$;wrt 16,A$[1,13],"17";dsp A$[1,11],"17"
230: prt "OPTION 030 Test.";spc ;prt "SETUP:","Connect an"
231: prt "86603A to 5335A","C' Input and","8660C TBO to"
232: prt "5335A Time","Base In.";spc 2
233: dsp E$;stp
234: wrt "sj","fu5";red "sj",E$;dsp A$[1,11],"17"
235: prt "Verify that","5335A displays","the frequency of","the 8660C."
236: prt "(150MHz+1.3GHz)";spc 2
237: dsp A$[1,11],"17",A$[16];stp
238: if X=1;gto "rpt"
239: "18":ent "OPTION 040 (1=Y, 0=N) ?",C;1000>D;.02>G
240: if C#0 and C#1;gto -1
241: if C=0;gto "rpt"
242: prt D$;wrt 16,A$[1,13],"18";dsp A$[1,11],"18"
243: prt "OPTION 040 Test.";spc ;prt "VERIFY:","All INPUT momen-"
244: prt "tary switches","are activated","& de-activated.";spc 2;dsp E$;stp
245: wrt "sj","inaflas1";wait D;wrt "sj","azlaal";wait D
246: wrt "sj","axl";wait D;wrt "sj","bxl";wait D
247: wrt "sj","bz1bal";wait D;wrt "sj","bflbs1";wait D
248: wrt "sj","colaul";wait D;wrt "sj","co0au0";wait D
249: wrt "sj","bf0bs0";wait D;wrt "sj","bz0ba0";wait D;wrt "sj","bx0";wait D
250: wrt "sj","ax0";wait D;wrt "sj","az0aa0";wait D;wrt "sj","intrlat0bt0"
251: prt "DAC Test.";spc 2;dsp E$;stp
252: for E=0 to 9;-5.12+2^E*.01>F;wrt "sj","ful4at",F,"bt",F
253: "DACS":red "sj",B$,F$;dsp A$[1,11],"18"
254: if abs(val(B$[11])-F)>G or abs(val(F$[11])-F)>G;gto "ERROR"
255: wait 1000;next F
256: for E=0 to 9;5.12-2^E*.01>F;wrt "sj","at",F,"bt",F
257: "DACS":red "sj",B$,F$;dsp A$[1,11],"18"
258: if abs(val(B$[11])-F)>G or abs(val(F$[11])-F)>G;gto "ERROR"
259: wait 1000;next E;prt "Pass DAC Test.";spc 2;gto 262
260: "EPROF":dsp "DACS are out of tolerance";beep;wait 500;beep;stp
261: gto "rpt"
262: dsp A$[1,11],"18",A$[16];sto
263: "rpt":ent "Repeat a Check Point (1=Y,0=N) ?",X
264: if X#1 and X#0;gto -1
265: if X=0;gto "end"
266: if X=1;ent "Check Point number (1 thru 18) ?",N
267: if N>18 or N<1;gto -1
268: jmp N
269: gto "1"
270: gto "2"
271: gto "3"
272: gto "4"
273: gto "5"
274: gto "6"
275: gto "7"
276: gto "8"
277: gto "9"
278: gto "10"
279: gto "11"
280: gto "12"
281: gto "13"
```

Table 4-4. 5335A HP-IB Verification Program Listing (9825A Controller (Continued))

```
282: gto "14"  
283: gto "15"  
284: gto "16"  
285: gto "17"  
286: gto "18"  
287: "end":prt C$;spc ;prt "  END OF 5335A", "  HP-IB TEST."  
288: beep;wait 500;beep;spc ;prt C$;spc 6  
289: wrt "sj","in";lcl "sj";dsp "END OF 5335A HP-IB TEST."  
290: end  
*24989
```

4-103. 5335A HP-IB VERIFICATION PROGRAM USING THE HP 85A CONTROLLER

4-104. The HP 85A program listed in *Table 4-5* exercises the 5335A through various operating modes via the HP-IB interface; it is also designed to test Option 020 (DVM), Option 030 (Channel C), and Option 040 (Programmable Input). If the 5335A successfully completes all phases of the verification program, then there is a very high probability that the interface and the counter are working properly.

4-105. To perform the verification, set up the 5335A as shown in *Figure 4-21*,

4-106. Perform the following steps:

- a. Key-in the program listed in *Table 4-5* or insert cassette, HP Part Number 59300-10002 into the HP 85A.
- b. Load and run file "Autost" (type: 'CHAIN "Autost"; press 'END LINE').
- c. Press the special function key corresponding to the model number to be tested. Follow instructions on HP 85A screen.
- d. Set up counter as described in the display.

e. Set the ADDRESS switches to any value between 00 and 30 inclusive, except the controller address (decimal 21).

f. Always press "CONTINUE" to advance program.

4-107. At the end of the HP-IB Verification Program, the controller will ask if you want to repeat one of the tests. Enter the appropriate number for the test needed (as indicated on the controller display), then press: "END LINE"; the selected test will then be repeated. Enter 0 if you wish to terminate the test program. At the end of the particular test, the question of whether you wish to repeat a test is asked again. If you want the same test, enter the test number, and press "END LINE".

4-108. Use the following procedure if it is desired to test a specific check-point with the HP-IB Verification Program.

- a. Load the tape in the normal manner and proceed until the controller displays the set-up information.
- b. Type "CONT 6210"; then press "END LINE". The program will advance to the end and ask if any of the tests need to be repeated. Then use the method described in the preceding paragraph.

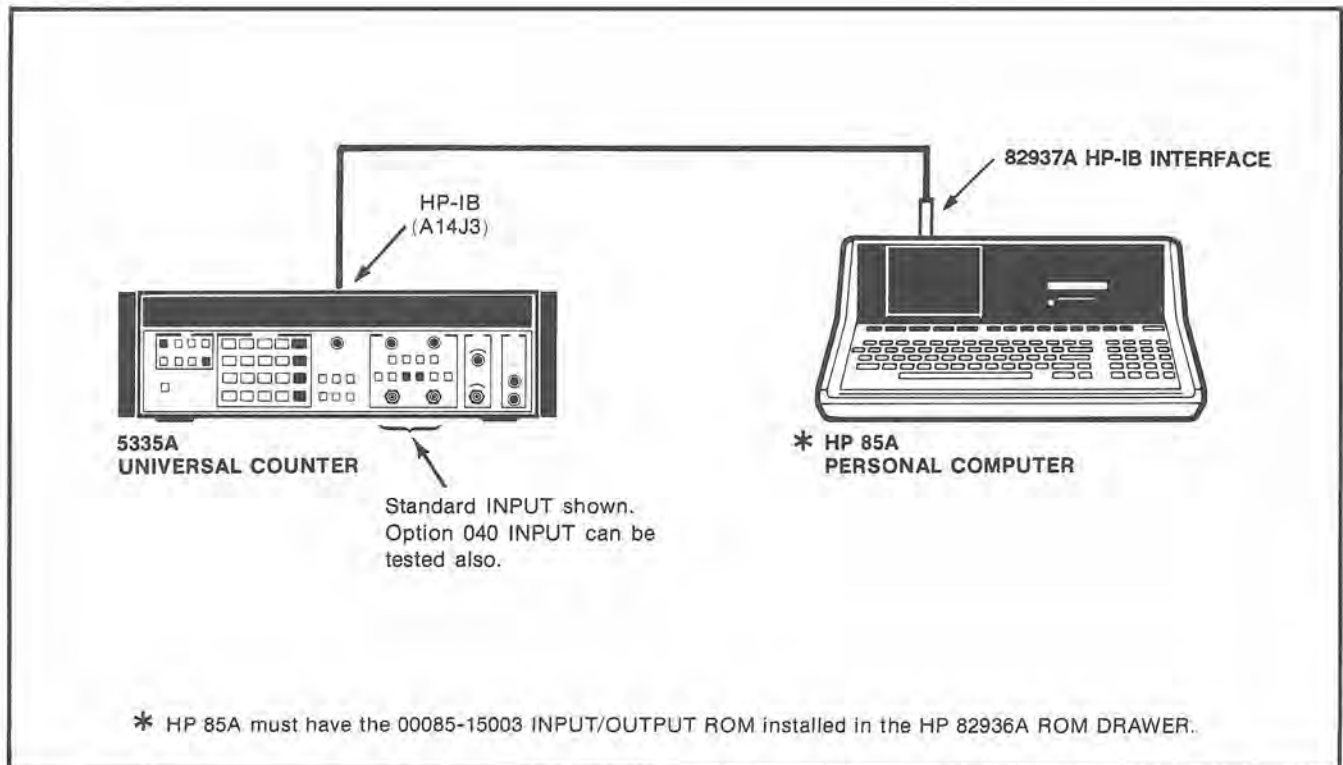

Figure 4-21. 5335A HP-IB Verification Set-Up (HP 85A Controller)

Table 4-5. 5335A HP-IB Verification Program Listing (HP 85A Controller)

```

10 REM      5335A HP-IB VERIFICATION PROGRAM - REV C      ***** "5335A" *****
20 REM      Revision Date:      3 de Diciembre de 1982      VGM
50 DIM A$(50),B$(21),C$(32),D$(45),E$(40),F$(21),A(30)
70 A$="CHECKPOINT      --Press 'CONT' when done."
90 C$="*****"
95 D$=" Please wait while DAC Test is      performed!"
110 E$="Press 'CONT' to perform test."
130 Y,X=0 @ G=.02 @ D=1000
150 BEEP 75,250 @ CLEAR @ DISP USING "4/"
155 DISP "After entering a 3 digit select" @ DISP
157 DISP "code (7XX), press 'END LINE'." @ DISP @ INPUT S
170 IF NOT (S=721) THEN 210 ELSE DISP "Error: Calculator Address      !!!"
190 WAIT 2000 @ GOTO 150
210 IF NOT (S>730) THEN 250 ELSE DISP "Out of Address Range: too High !"
230 WAIT 2000 @ GOTO 150
250 IF NOT (S<700) THEN 290 ELSE DISP "Out of Address Range: too Low !!"
270 WAIT 2000 @ GOTO 150
290 CRT IS 1 @ PRINTER IS 2 @ NORMAL @ RESET 7 @ LOCAL S @ CLEAR @ DISP C$
310 DISP "      5335A UNIVERSAL COUNTER";" HP-IB Verification Program."
330 DISP C$ @ DISP USING "2/"
350 DISP "CONNECT: 'TIME BASE OUT';"from rear panel to INPUT A." @ DISP
355 DISP "Set 'GATE ADJ' to CCW and      Channel A & B INPUT to:"
357 DISP "PRESET, 50 Ohms, X1, DC, and      positive slope."
370 DISP @ DISP USING "#,K,/" ; A$(16) @ PAUSE
390 CLEAR @ DISP C$ @ GOSUB 6410
410 DISP A$(1,13);"1:";"      *** 5335A POWER-UP CHECK ***" @ DISP
430 DISP "Turn 5335A power OFF then ON;"VERIFY:"
470 DISP "* RED LED 'STBY' lamp is OFF;"
490 DISP "* All lamps turn ON momentarily;"
510 DISP "* Selected HP-IB add. displayed;"
530 DISP "* 'FREQ A' & 'Hz' lamps are ON;"
550 DISP "* Display shows: 10.000 000 +6"
570 DISP " with 'Hz' LED ON; 'GATE' & 'A'"
590 DISP " Trigger light flashing." @ DISP @ DISP USING "#,K,/" ; A$(16)
595 PAUSE
610 IF X<>0 THEN 6210
630 CLEAR @ DISP C$ @ GOSUB 6410 @ DISP @ RESET 7 @ OUTPUT S ;"in"
650 DISP A$(1,11);"2:";" LOCAL/RESET TEST" @ DISP USING "2/"
670 DISP "Press LOCAL/RESET on 5335A front" @ DISP
690 DISP "panel and verify that 'REMOTE'" @ DISP @ DISP "LED goes out."
710 DISP USING "3/" @ DISP A$(16) @ PAUSE
730 IF X<>0 THEN 6210
750 CLEAR @ DISP C$ @ GOSUB 6410 @ DISP
770 DISP A$(1,11);"3:";"      *** LOCAL-LOCKOUT TEST ***" @ DISP
790 DISP "Press LOCAL/RESET and verify" @ DISP
810 DISP "that 'REMOTE' LED stays ON."
830 DISP USING "2/" @ OUTPUT S @ LOCAL LOCKOUT 7 @ DISP @ DISP A$(16) @ PAUSE
850 IF X<>0 THEN 6210
870 CLEAR @ DISP C$ @ GOSUB 6410 @ DISP
890 DISP A$(1,11);"4:";" 'WAIT' & 'SRQ' mode TEST" @ DISP
910 DISP "Verify the following LEDs are"
930 DISP "lit for five (5) measurements:" @ DISP
950 DISP "      * TALK"
970 DISP "      * LISTEN"
990 DISP "      * SRQ"
1010 DISP "      * REMOTE" @ DISP
1030 DISP E$ @ LOCAL S @ PAUSE
1050 CLEAR @ DISP C$ @ DISP
1070 DISP A$(1,11);"4:";" 'WAIT' & 'SRQ' mode TEST" @ BEEP @ I=0 @ DISP
1090 OUTPUT S ;"inga.02" @ ON INTR 7 GOSUB 1150
1110 ENABLE INTR 7;8 @ OUTPUT S ;"walsrl" @ WAIT 100

```

Table 4-5. 5335A HP-IB Verification Program Listing (HP 85A Controller) (Continued)

```
1130 IF NOT (I>5) THEN 1110 ELSE 1190
1150 FOR I=1 TO 5 @ STATUS 7,1 ; T@ ENTER S ; B$@ DISP " ";B$
1170 OUTPUT S ; "re" @ WAIT 1000 @ NEXT I @ RETURN
1190 DISP USING "3/" @ DISP A$[16] @ BEEP @ PAUSE
1210 IF X<>0 THEN 6210
1230 CLEAR @ DISP C$ @ GOSUB 6410 @ DISP
1250 DISP A$[1,12];"5:";" *** TEACH - LEARN mode TEST ***" @ DISP
1270 DISP "Verify that the 5335A displays:";" '11. 224 49 +15 Hz'."
1290 DISP USING "4/" @ DISP E$
1310 PAUSE @ REMOTE S
1330 OUTPUT S ; "fulms1122448800" @ DISP A$[16] @ BEEP @ PAUSE
1350 CLEAR @ DISP C$ @ DISP
1370 DISP A$[1,12];"5:";" *** TEACH - LEARN mode TEST ***" @ DISP
1390 DISP "5335A Counter will teach the";"HP-85A controller the front"
1410 DISP "panel setup." @ DISP @ OUTPUT S ; "pq"
1430 FOR I=1 TO 30 @ ENTER S USING "#,B" ; A(I) @ NEXT I
1450 IF NOT (A(24)=17 AND A(25)=34 AND A(26)=68) THEN 1430
1470 IF NOT (A(28)=0 AND A(29)=0) THEN 1430
1490 DISP A$[16] @ I=0 @ BEEP @ PAUSE
1510 CLEAR @ DISP C$ @ DISP
1530 DISP A$[1,12];"5:";" *** TEACH - LEARN mode TEST ***" @ DISP
1550 DISP "Verify that the 5335A displays";"100. 000 00 -9 with 'S' and"
1570 DISP "Function PER A LED's ON,";"and 'GATE' LED flashing."
1590 OUTPUT S ; "fu9" @ LOCAL S @ DISP USING "3/" @ DISP A$[16] @ BEEP @ PAUSE
1610 CLEAR @ DISP C$ @ DISP
1630 DISP A$[1,12];"5:";" *** TEACH - LEARN mode TEST ***" @ DISP
1650 DISP "5335A Counter will learn";"from HP-85A controller." @ DISP
1670 DISP "Verify that the 5335A displays:";"'11. 224 49 +15 Hz.'"
1690 DISP USING "2/" @ OUTPUT S USING "#,K" ; "pb"
1710 FOR I=1 TO 30 @ OUTPUT S USING "#,B" ; A(I) @ NEXT I @ LOCAL S
1730 DISP A$[16] @ BEEP @ PAUSE
1750 IF X<>0 THEN 6210
1770 CLEAR @ DISP C$ @ GOSUB 6410 @ DISP
1790 DISP A$[1,12];"6:";"*** FREQUENCY 'B' mode TEST ***" @ DISP
1810 DISP "SETUP:";"Connect Time Base Out (TBO)"
1830 DISP "from rear panel to INPUT B." @ DISP USING "2/"
1850 DISP E$ @ PAUSE
1870 OUTPUT S ; "co0ful7" @ ENTER S ; B$
1890 CLEAR @ DISP A$[1,12];"6:";"*** FREQUENCY 'B' mode TEST ***" @ DISP
1910 DISP "VERIFY:" @ DISP @ DISP "* 5335A displays:" @ DISP " ";B$
1970 DISP "* 'GATE' lamp flashing;" @ DISP "* 'TALK' & 'REMOTE' lamps are ON"
2010 DISP "* All FUNCTION lamps are OFF;"
2030 DISP "* 'B' trigger light flashing." @ DISP
2050 DISP @ DISP A$[16] @ PAUSE
2070 IF X<>0 THEN 6210
2090 CLEAR @ DISP C$ @ GOSUB 6410 @ DISP
2110 DISP A$[1,12];"7:";"*** TRIGGER LEVEL mode TEST ***" @ DISP USING "2/"
2150 OUTPUT S ; "walful4" @ ENTER S ; B$,F$@ DISP "VERIFY:" @ DISP
2190 DISP "Trig. Lvl A = ";B$[11,19];" Volts" @ DISP
2210 DISP "Trig. Lvl B = ";F$[11,19];" Volts"
2230 DISP USING "2/" @ DISP A$[16] @ BEEP @ PAUSE
2250 IF X<>0 THEN 6210
2270 CLEAR @ DISP C$ @ GOSUB 6410 @ DISP
2290 DISP A$[1,12];"8:";"*** GATE TIME mode TEST ***" @ DISP
2310 DISP " GATE ADJ. Normal Range test:" @ DISP
2350 DISP "Vary 'GATE ADJ.' pot and verify";"change in Gate Time displayed,"
2370 DISP "NOMINALLY, between 20 millisec.;"and 4 seconds."
2390 DISP USING "2/" @ OUTPUT S ; "wa0ful3gm0rh0"
2410 DISP A$[16] @ ENTER S ; B$@ BEEP @ PAUSE
2430 CLEAR @ DISP @ DISP A$[1,12];"8:";"*** GATE TIME mode TEST ***" @ DISP
2450 DISP " GATE ADJ. Fast Range test:" @ DISP
```

Table 4-5. 5335A HP-IB Verification Program Listing (HP 85A Controller) (Continued)

```

2470 DISP "Vary 'GATE ADJ.' pot and verify";"change in Gate Time displayed,"
2490 DISP "NOMINALLY, between 100 microsec.;"and 20 milliseconds."
2510 DISP USING "2/" @ OUTPUT S ;"ful3gmlrh0"
2530 ENTER S ; B$@ DISP @ DISP A$[16] @ BEEP @ PAUSE
2550 IF X<>0 THEN 6210
2570 CLEAR @ DISP C$ @ GOSUB 6410 @ DISP
2590 DISP A$[1,12];"9:";"* RISE and FALL TIME mode TEST *" @ DISP
2610 DISP "SETUP:";"Connect Time Base Out (TBO)"
2630 DISP "from rear panel to INPUT A." @ DISP USING "3/" @ DISP E$ @ PAUSE
2670 CLEAR @ DISP A$[1,13];"9:";"* RISE and FALL TIME mode TEST *" @ DISP
2675 OUTPUT S ;"inful0" @ WAIT 3000 @ ENTER S ; B$
2690 DISP " *** RISE TIME test ***" @ DISP @ DISP "VERIFY:"
2730 DISP "** 5335A Displays:" @ DISP " ";B$
2750 DISP "** RISE/FALL A LED is ON;"
2770 DISP "** Gate Mode MIN LED is ON;"
2790 DISP "** 'GATE' LED is flashing;"
2810 DISP "'A' & 'B' trig. lamps blinking"
2830 DISP "** 'TALK' and 'REMOTE' LED's ON." @ DISP
2852 DISP USING "#,K,/" ; A$[16] @ ENTER S ; B$@ BEEP @ PAUSE
2870 CLEAR @ DISP A$[1,12];"9:";"* RISE and FALL TIME mode TEST *" @ DISP
2875 OUTPUT S ;"asl" @ WAIT 3000 @ ENTER S ; B$
2890 DISP " *** FALL TIME test ***" @ DISP
2915 DISP "Verify that 5335A displays:" @ DISP " ";B$ @ DISP USING "4/"
2975 DISP @ DISP A$[16] @ BEEP @ PAUSE
2990 IF X<>0 THEN 6210
3010 CLEAR @ DISP C$ @ GOSUB 6410
3030 DISP A$[1,12];"10:";" *** OVERFLOW mode TEST ***" @ DISP
3050 DISP "Verify that the ONLY lamps lit";"during the 11 second wait"
3070 DISP "period are :"
3090 DISP "'Hz' , 'GATE' , 'LISTEN',"
3110 DISP "'REMOTE', FREQ A ,";"* Manual GATE MODE and"
3130 DISP "'A' trigger lamp (flashing);"
3150 DISP "** 5335A Displays: '0.'" @ DISP USING "2/" @ DISP USING "#,K,/" ; E$
3155 PAUSE
3170 OUTPUT S ;"inwalgm3" @ DISP A$[1,10];" 10:";A$[16] @ WAIT 11000
3190 OUTPUT S ;"gc" @ ENTER S ; B$@ BEEP @ CLEAR @ DISP
3210 DISP A$[1,12];"10:";" *** OVERFLOW mode TEST ***" @ DISP
3230 DISP "VERIFY: " @ DISP
3250 DISP "** 5335A displays:" @ DISP " ";B$
3270 DISP "'LISTEN' and 'GATE' lamps OFF"
3290 DISP "'TALK' lamp ON."
3310 DISP USING "3/" @ DISP A$[16] @ PAUSE
3330 IF X<>0 THEN 6210
3350 CLEAR @ DISP C$ @ GOSUB 6410 @ DISP
3355 OUTPUT S ;"in"
3370 DISP A$[1,12];"11:";"*** TIME INTERVAL mode TEST ***" @ DISP
3395 OUTPUT S ;"fu2bslcolwa0" @ OUTPUT S ;"re" @ ENTER S ; B$@ DISP "VERIFY:"
3410 DISP "** 5335A displays:" @ DISP " ";B$
3430 DISP "'GATE' lamp flashing;"
3450 DISP "'TALK' and 'REMOTE' lamps ON;"
3470 DISP "** TIME A->B lamp is ON;"
3490 DISP "'MIN' GATE MODE lamp is ON;"
3510 DISP "'A' & 'B' trig. lamps flashing" @ DISP
3530 DISP USING "#,K,/" ; A$[16] @ BEEP @ PAUSE
3550 CLEAR @ DISP A$[1,13];"11:";"*INVERSE TIME INTERVAL mode TEST" @ DISP
3570 DISP "VERIFY:" @ DISP @ OUTPUT S ;"fu6" @ ENTER S ; B$
3590 DISP "** 5335A displays approximately:" @ DISP " ";B$
3610 DISP "'GATE' lamp flashing;"
3630 DISP "'TALK' and 'REMOTE' LED's ON;"
3650 DISP "1/TIME A->B lamp is ON;"
3670 DISP "'MIN' GATE MODE lamp is ON; * 'A' & 'B' trig. lamps flashing"

```

Table 4-5. 5335A HP-IB Verification Program Listing (HP 85A Controller) (Continued)

```
3690 BEEP @ DISP @ DISP A$[16] @ PAUSE
3710 IF X<>0 THEN 6210
3730 CLEAR @ DISP C$ @ GOSUB 6410 @ DISP
3750 DISP A$[1,12];"12:";"** FRONT PANEL SWITCH TEST **" @ DISP
3770 DISP "Press each momentary type key on";"the 5335A front panel."
3790 DISP
3810 DISP "A number will be displayed when";"a key is pressed corresponding"
3830 DISP "to the following figure (INPUT"
3850 DISP "section is for Option 040 ONLY):" @ DISP @ DISP E$ @ PAUSE
3890 PRINT "      MATH                FUNCTION" @ PRINT
3910 PRINT " 01 03 05 07          09 13 17 21 25" @ PRINT
3930 PRINT " 02 04 06 08          10 14 18 22 26" @ PRINT
3950 PRINT "                        11 15 19 23 27" @ PRINT
3970 PRINT "                        12 16 20 24 28" @ PRINT USING "3/"
3990 PRINT "  GATE MODE                INPUT" @ PRINT
4010 PRINT " 29 31 33          35 37 39 41 43 45" @ PRINT
4030 PRINT " 30 32 34          36 38 40 42 44 46" @ PRINT USING "6/"
4070 OUTPUT S ;"fu99ms17" @ WAIT 100 @ LOCAL S
4090 DISP A$[1,10];" 12 ";A$[16] @ PAUSE
4130 IF X<>0 THEN 6210
4150 CLEAR @ DISP C$ @ GOSUB 6410
4170 DISP A$[1,12];"13:";" ** FRONT END INPUT TEST **" @ DISP
4190 DISP "VERIFY:"
4210 DISP "** All LEDs are ON (about 5 secs)";"** 5335A displays 'FE PASS';"
4230 DISP "** Then 5335A will display";" the voltages at A2U4(2,12,10);"
4250 DISP " NOMINAL values are:";"      5. 000 00 V      ";"      3. 100 00 V"
4270 DISP "      -5. 200 00 v"
4290 OUTPUT S ;"fu99ms0" @ DISP @ DISP USING "#,K,/" ; A$[16] @ PAUSE
4295 OUTPUT S ;"in"
4310 IF X<>0 THEN 6210
4330 CLEAR @ DISP C$ @ GOSUB 6410 @ DISP @ A=0
4350 DISP "If DVM Option is installed,";"enter 1; if not, enter 0, then"
4355 DISP "press 'END LINE'." @ DISP @ INPUT A
4370 IF A<>0 AND A<>1 THEN 4330
4390 IF A=0 THEN 4790
4420 CLEAR @ DISP C$ @ GOSUB 6410 @ DISP @ OUTPUT S ;"in" @ LOCAL S
4430 DISP A$[1,12];"14:";"** OPTION 020 * DVM * TEST **" @ DISP
4450 DISP "SETUP:";"a) Connect Trig. Level 'A' from"
4470 DISP "  rear panel to DVM input jack;" @ DISP
4490 DISP "b) Set PRESET 'A' off,";" but in CCW position."
4520 DISP USING "2/" @ DISP E$ @ PAUSE
4530 OUTPUT S ;"ful5" @ ENTER S ; B$ @ CLEAR @ DISP C$ @ DISP
4550 DISP A$[1,12];"14:";"** OPTION 020 * DVM * TEST **" @ DISP
4570 DISP "Verify that 5335A displays: " @ DISP
4590 DISP " ";B$[10,19];" 'Volts'" @ DISP USING "2/"
4610 DISP A$[16] @ BEEP @ PAUSE
4620 CLEAR @ DISP C$ @ DISP
4622 DISP A$[1,12];"14:";"** OPTION 020 * DVM * TEST **" @ DISP USING "2/"
4630 DISP "Rotate Channel 'A' level control";"to the CW position."
4650 DISP USING "2/" @ DISP A$[16] @ PAUSE
4670 CLEAR @ DISP C$ @ DISP
4690 DISP A$[1,12];"14:";"** OPTION 020 * DVM * TEST **" @ DISP
4710 ENTER S ; B$ @ DISP "Verify that 5335A displays: " @ DISP
4730 DISP " ";B$[10,19];" 'Volts'" @ DISP USING "3/" @ DISP A$[16]
4750 BEEP @ PAUSE
4770 IF X<>0 THEN 6210
4790 CLEAR @ DISP C$ @ GOSUB 6410 @ DISP @ B=0
4810 DISP "If Channel C Opt. is installed,";"enter 1; if not, enter 0, then"
4815 DISP "press: 'END LINE'." @ DISP @ INPUT B
4830 IF B<>0 AND B<>1 THEN 4790
4850 IF B=0 THEN 5090
```

Scanned by KN5U
Table 4-5. 5335A HP-IB Verification Program Listing (HP 85A Controller) (Continued)

```
4855 CLEAR @ DISP C$ @ GOSUB 6410 @ DISP
4870 DISP A$[1,12];"15:";"OPTION 030 - CHANNEL 'C' TEST" @ DISP
4890 DISP "SETUP:";"a) Connect an 86603A to the";" 5335A INPUT 'C';"
4910 DISP "b) Connect the 8660C TBO to the";" 5335A Time Base In."
4930 DISP USING "3/" @ DISP E$ @ PAUSE
4950 OUTPUT S ;"fu5" @ ENTER S ; B$
4970 CLEAR @ DISP C$ @ DISP
4990 DISP A$[1,12];"15:";"OPTION 030 - CHANNEL 'C' TEST" @ DISP
5010 DISP "Verify that 5335A displays the";"frequency of the 8660C"
5030 DISP "(150MHz -> 1.3GHz). " @ DISP USING "2/" @ DISP " ";B$
5050 DISP USING "2/" @ DISP A$[16] @ BEEP @ PAUSE
5070 IF X<>0 THEN 6210
5090 CLEAR @ DISP C$ @ GOSUB 6410 @ DISP @ C=0
5095 DISP "If Option 040 is installed,";"enter 1; if not, enter 0, then"
5097 DISP "press: 'END LINE'." @ DISP @ INPUT C
5130 IF C<>0 AND C<>1 THEN 5090
5150 IF C=0 THEN 6210
5170 CLEAR @ DISP C$ @ GOSUB 6410 @ DISP
5190 DISP A$[1,12];"16:";"OPT 040 PROGRAMMABLE INPUT TEST" @ DISP
5210 DISP "Verify that all INPUT momentary";"switches are activated and"
5230 DISP "de-activated; the switches LED";"should turn ON then OFF."
5250 DISP USING "4/" @ DISP E$ @ PAUSE
5270 OUTPUT S ;"inaflasl" @ WAIT D
5290 OUTPUT S ;"azlaal" @ WAIT D
5310 OUTPUT S ;"ax1" @ WAIT D
5330 OUTPUT S ;"bx1" @ WAIT D
5350 OUTPUT S ;"bz1bal" @ WAIT D
5370 OUTPUT S ;"bflbsl" @ WAIT D
5390 OUTPUT S ;"colaul" @ WAIT D
5410 OUTPUT S ;"co0au0" @ WAIT D
5430 OUTPUT S ;"bf0bs0" @ WAIT D
5450 OUTPUT S ;"bz0ba0" @ WAIT D
5470 OUTPUT S ;"bx0" @ WAIT D
5490 OUTPUT S ;"ax0" @ WAIT D
5510 OUTPUT S ;"az0aa0" @ WAIT D
5530 OUTPUT S ;"intrlat0bt0"
5550 CLEAR @ DISP C$ @ DISP
5570 DISP A$[1,12];"16:";"OPT 040 PROGRAMMABLE INPUT TEST" @ DISP
5590 DISP USING "2/" @ DISP A$[16] @ BEEP @ PAUSE
5610 CLEAR @ DISP C$ @ DISP
5630 DISP A$[1,12];"16:";"OPT 040 PROGRAMMABLE INPUT TEST" @ DISP
5650 DISP @ DISP "***** DAC Test *****"
5670 DISP USING "3/" @ DISP D$[1,32] @ DISP @ DISP " ";D$[33] @ BEEP
5690 FOR E=0 TO 9 @ F=-5.12+2^E*.01 @ GOSUB 5750
5710 FOR E=0 TO 9 @ F=5.12-2^E*.01 @ GOSUB 5750
5730 GOTO 5850
5750 OUTPUT S ;"ful4walat";F;"bt";F @ WAIT D @ ENTER S ; B$,F$
5770 IF ABS(VAL(B$[11])-F)>G THEN 5930
5790 IF ABS(VAL(F$[11])-F)>G THEN 6070
5810 NEXT E @ WAIT 2000 @ RETURN
5850 OUTPUT S ;"wa0" @ CLEAR @ DISP C$ @ DISP
5870 DISP A$[1,12];"16:";"OPT 040 PROGRAMMABLE INPUT TEST"
5890 DISP USING "3/" @ DISP " **** Passed DAC Test. ****" @ GOTO 6190
5930 CLEAR @ DISP C$ @ DISP
5950 DISP A$[1,12];"16:";"OPT 040 PROGRAMMABLE INPUT TEST" @ DISP
5970 GOSUB 6410
5990 DISP @ DISP "***** DAC Test *****" @ DISP USING "2/"
6010 DISP "DAC is out of tolerance:" @ DISP
6030 DISP "ChA Prog. Lvl= ";F;"ChA Actual Lvl= ";B$[11]
6050 DISP "Tolerance= ";G @ END
6070 CLEAR @ DISP C$ @ DISP
```

Table 4-5. 5335A HP-IB Verification Program Listing (HP 85A Controller) (Continued)

```
6090 DISP A$[1,12];"16:";"OPT 040 PROGRAMMABLE INPUT TEST" @ DISP
6110 GOSUB 6410
6130 DISP "DAC is out of tolerance:" @ DISP
6150 DISP "ChB Prog. Lvl=      ";F;"ChB Actual Lvl=      ";F$[11]
6170 DISP "Tolerance=      ";G @ END
6190 DISP USING "4/" @ DISP A$[16] @ BEEP @ PAUSE
6210 BEEP 75,250 @ CLEAR @ DISP USING "4/"
6212 DISP "This is the end of the program." @ DISP USING "2/"
6215 DISP "If you need to repeat a Check Point, enter the Check Point"
6217 DISP "number (1 thru 16), if not,"
6220 DISP "enter 0, then press 'END LINE'." @ DISP @ INPUT X
6230 IF X<0 OR X>16 THEN 6210 ELSE OUTPUT S ;"wa0"
6250 IF X=0 THEN 6330
6295 IF X>12 THEN 6315
6310 ON X GOTO 390,630,750,870,1230,1770,2090,2270,2570,3010,3350,3730
6315 ON X-12 GOTO 4150,4330,4790,5090
6330 CLEAR @ DISP USING "4/" @ DISP C$ @ DISP
6350 DISP " END OF 5335A UNIVERSAL COUNTER";" HP-IB Verification Test."
6370 DISP @ DISP C$ @ GOSUB 6410 @ OUTPUT S ;"in" @ LOCAL S @ REWIND @ END
6410 BEEP @ WAIT 250 @ BEEP @ RETURN
```

OPERATION VERIFICATION RECORD (TEST CARD)

| HEWLETT-PACKARD MODEL 5335A UNIVERSAL COUNTER | | Date _____ | |
|--|--------------------------------------|------------------|-------|
| Test Performed by: _____ | | Serial No. _____ | |
| STEP NO. | DESCRIPTION | RESULTS | |
| | | PASS | FAIL |
| I | POWER-UP/SELF TEST | _____ | _____ |
| II | SUPERCHECK | _____ | _____ |
| III | KEYBOARD CHECK | _____ | _____ |
| IV | REAR PANEL/EXTERNAL ARM SWITCH TEST | _____ | _____ |
| V | KEYBOARD CHECK | _____ | _____ |
| VI | DVM TEST (Option 020) | _____ | _____ |
| VII | CHANNEL C TEST (Option 030) | _____ | _____ |
| VIII | PROGRAMMABLE INPUT TEST (Option 040) | _____ | _____ |

PERFORMANCE TEST CARD

HEWLETT-PACKARD MODEL 5335A
UNIVERSAL COUNTER

Serial Number: _____

Test Performed by: _____

Date: _____

| TEST | DESCRIPTION | PASS | FAIL | ACTUAL VALUE |
|------|-------------------------------------|-------|-------|--------------|
| I | POWER-UP/SELF TEST | _____ | _____ | |
| II | SUPERCHECK | _____ | _____ | |
| III | KEYBOARD CHECK | _____ | _____ | |
| IV | REAR PANEL/EXTERNAL ARM SWITCH TEST | _____ | _____ | |
| V | GATE TIME | | | |
| | 20 ms to 4 s | _____ | _____ | |
| | 100 μ s to 20 ms | _____ | _____ | |
| VI | FREQUENCY RESPONSE and SENSITIVITY | | | |
| | Channel A (<25 mV rms): | | | |
| | A) DC to 20 MHz (dc coupled) | | | |
| | 0.01 Hz | | | _____ |
| | 10 Hz | | | _____ |
| | 100 kHz | | | _____ |
| | 10 MHz | | | _____ |
| | 20 MHz | | | _____ |
| | B) 30 Hz — 20 MHz (ac coupled) | | | |
| | 30 Hz | | | _____ |
| | 10 kHz | | | _____ |
| | 1 MHz | | | _____ |
| | 10 MHz | | | _____ |
| | 20 MHz | | | _____ |
| | C) 200 kHz — 20 MHz (50 Ω) | | | |
| | 200 kHz | | | _____ |
| | 500 kHz | | | _____ |
| | 1 MHz | | | _____ |
| | 10 MHz | | | _____ |
| | 20 MHz | | | _____ |
| | D) 20 MHz — 200 MHz (dc coupled) | | | |
| | 20 MHz | | | _____ |
| | 50 MHz | | | _____ |
| | 125 MHz | | | _____ |
| | 200 MHz | | | _____ |
| | E) 20 MHz — 200 MHz (ac coupled) | | | |
| | 20 MHz | | | _____ |
| | 50 MHz | | | _____ |
| | 125 MHz | | | _____ |
| | 200 MHz | | | _____ |

PERFORMANCE TEST CARD (Continued)

| TEST | DESCRIPTION | PASS | FAIL | ACTUAL VALUE |
|------|--|--|--|--|
| VI | <p>FREQUENCY RESPONSE and SENSITIVITY Channel B (<25 mV rms):</p> <p>A) DC to 20 MHz (dc coupled) 0.01 Hz 10 Hz 100 kHz 10 MHz 20 MHz</p> <p>B) 30 Hz — 20 MHz (AC coupled) 30 Hz 10 kHz 1 MHz 10 MHz 20 MHz</p> <p>C) 200 kHz — 20 MHz (50Ω) 200 kHz 500 kHz 1 MHz 10 MHz 20 MHz</p> <p>D) 20 MHz — 100 MHz (dc coupled) 20 MHz 50 MHz 100 MHz</p> <p>E) 20 MHz — 100 MHz (ac coupled) 20 MHz 50 MHz 100 MHz</p> | | | <p>_____</p> <p>_____</p> <p>_____</p> <p>_____</p> <p>_____</p> <p>_____</p> <p>_____</p> <p>_____</p> <p>_____</p> <p>_____</p> <p>_____</p> <p>_____</p> <p>_____</p> <p>_____</p> <p>_____</p> <p>_____</p> <p>_____</p> <p>_____</p> <p>_____</p> <p>_____</p> <p>_____</p> <p>_____</p> <p>_____</p> <p>_____</p> <p>_____</p> |
| VII | <p>RATIO A/B Display (± 1 count):</p> <p>10 Hz 1. 10 kHz 1.00 5 MHz 1. 000 0 20 MHz 1. 000 00 50 MHz 2. 500 00 100 MHz 5. 000 00 150 MHz 7. 500 00 200 MHz 10. 000 00</p> | <p>_____</p> <p>_____</p> <p>_____</p> <p>_____</p> <p>_____</p> <p>_____</p> <p>_____</p> <p>_____</p> <p>_____</p> | <p>_____</p> <p>_____</p> <p>_____</p> <p>_____</p> <p>_____</p> <p>_____</p> <p>_____</p> <p>_____</p> <p>_____</p> | <p>_____</p> <p>_____</p> <p>_____</p> <p>_____</p> <p>_____</p> <p>_____</p> <p>_____</p> <p>_____</p> <p>_____</p> |
| VIII | <p>TIME INTERVAL AND INVERSE TIME INTERVAL Time Interval (100 ± 5) ns Inverse Time Interval (10.0 ± 0.5)10^6 units/s</p> | <p>_____</p> <p>_____</p> | <p>_____</p> <p>_____</p> | <p>_____</p> <p>_____</p> |
| IX | <p>PULSE WIDTH A AND PULSE WIDTH B Pulse Width A Positive Pulse: (4.000 $\mu s \pm 5$ ns) Negative Pulse: (6.000 $\mu s \pm 5$ ns) Pulse Width B Negative Pulse: (6.000 $\mu \pm 5$ ns) Positive Pulse: (4.000 $\mu \pm 5$ ns)</p> | <p>_____</p> <p>_____</p> <p>_____</p> <p>_____</p> <p>_____</p> <p>_____</p> <p>_____</p> <p>_____</p> | <p>_____</p> <p>_____</p> <p>_____</p> <p>_____</p> <p>_____</p> <p>_____</p> <p>_____</p> <p>_____</p> | <p>_____</p> <p>_____</p> <p>_____</p> <p>_____</p> <p>_____</p> <p>_____</p> <p>_____</p> <p>_____</p> |

PERFORMANCE TEST CARD (Continued)

| TEST | DESCRIPTION | PASS | FAIL | ACTUAL VALUE |
|---------|---------------------------------|-------|-------|--------------|
| X | RISE and FALL TIME A | | | |
| | Rise Time A (400 +82) ns | _____ | _____ | |
| | Fall Time A (400 +82) ns | _____ | _____ | |
| XI | SLEW RATE A | | | |
| | (2.00 ±0.65) V/s | _____ | _____ | |
| XII | PHASE A rel B | | | |
| | (180 ±1.5) degrees | _____ | _____ | |
| XIII | DVM TEST (Option 020) | | | |
| | Shorted input: | | | |
| | 0V ± 600 mV | _____ | _____ | |
| | ±4.000V ±3.8 mV | _____ | _____ | |
| | ±40.00V ±38 mV | _____ | _____ | |
| | ±400.0V ±380 mV | _____ | _____ | |
| XIV | CHANNEL C TEST (Option 030) | | | |
| | A) 150 MHz to 1 GHz (≤ -27 dBm) | | | |
| | 150 MHz | | | _____ |
| | 500 MHz | | | _____ |
| | 800 MHz | | | _____ |
| | 1.0 GHz | | | _____ |
| | B) 1 GHz to 1.3 GHz (≤ -7 dBm) | | | |
| | 1.1 GHz | | | _____ |
| 1.3 GHz | | | _____ | |

SECTION V ADJUSTMENTS

5-1. INTRODUCTION

5-2. This section describes the adjustments required to maintain the HP 5335A operating characteristics within specifications. Adjustments should be made when required, such as after a performance test failure or when components are replaced that may affect an adjustment.

5-3. *Table 5-1* lists the adjustment procedures, in the recommended order of performance, and indicates the adjustable components involved. *Table 5-2* lists the additional adjustment procedures for a 5335A equipped with Option 040.

5-4. EQUIPMENT REQUIRED

5-5. The test equipment required for the adjustment procedures is listed in *Table 1-4*, Recommended Test Equipment. Substitute instruments may be used if they meet the critical specifications.

5-6. ADJUSTMENT LOCATIONS

5-7. Adjustment locations are identified in the procedure for each adjustment.

5-8. SAFETY CONSIDERATIONS

5-9. This section contains warnings that must be followed for your protection and to avoid damage to the instrument.

WARNING

MAINTENANCE DESCRIBED HEREIN IS PERFORMED WITH POWER SUPPLIED TO THE INSTRUMENT, AND PROTECTIVE COVERS

REMOVED. SUCH MAINTENANCE SHOULD BE PERFORMED ONLY BY SERVICE-TRAINED PERSONNEL WHO ARE AWARE OF THE HAZARDS INVOLVED (FOR EXAMPLE, FIRE AND ELECTRICAL SHOCK). WHERE MAINTENANCE CAN BE PERFORMED WITHOUT POWER APPLIED, THE POWER SHOULD BE REMOVED.

BEFORE ANY REPAIR IS COMPLETED, ENSURE THAT ALL SAFETY FEATURES ARE INTACT AND FUNCTIONING, AND THAT ALL NECESSARY PARTS ARE CONNECTED TO THEIR PROTECTIVE GROUNDING MEANS.

5-10. ADJUSTMENT PROCEDURES

5-11. A1 Power Supply Adjustment Procedure

5-12. The voltage supplies in the 5335A that require adjustment are +3 volts, and +15 volts. To perform these adjustments, proceed as follows:

- a. Connect the positive terminal of the DVM to A1U4(1) and the negative terminal to chassis ground.
- b. Adjust A1R1 for a DVM reading of 3.000 Vdc (± 20 mV).

- c. Call up Diagnostic routine #32, as follows:

Press: SCALE
SMOOTH
9, 9
ENTER (wait for 5 seconds)
SCALE
3, 2
ENTER

Table 5-1. Adjustments

| ASSEMBLY | | ADJUSTMENTS | COMMENTS |
|-----------------|--------|-----------------------------------|--|
| NAME | NUMBER | | |
| Power Supply | A1 | A1R1, R15 | Uses Diagnostic Loop #32. |
| Input Amplifier | A3 | A3R37, R47, R88, R96 | Uses Special Function Loop #17. |
| D.V.M. | A8 | Zero Adj, Ref Sym, Low, Med, High | Allow 20 min warmup. Perform adjustments in indicated order. |
| C CHANNEL | A9 | A9R22, R23, R24 | Allow 5 minutes for warmup. |
| Oscillator | A4/A15 | A4C6/FREQ ADJUST | Check against known House Standard. |
| Level Shifter | A2 | A2R65, R66 | Uses Special Function Loop #17. |
| Rear Panel | A6 | A6R22 | Uses external signal generator. |

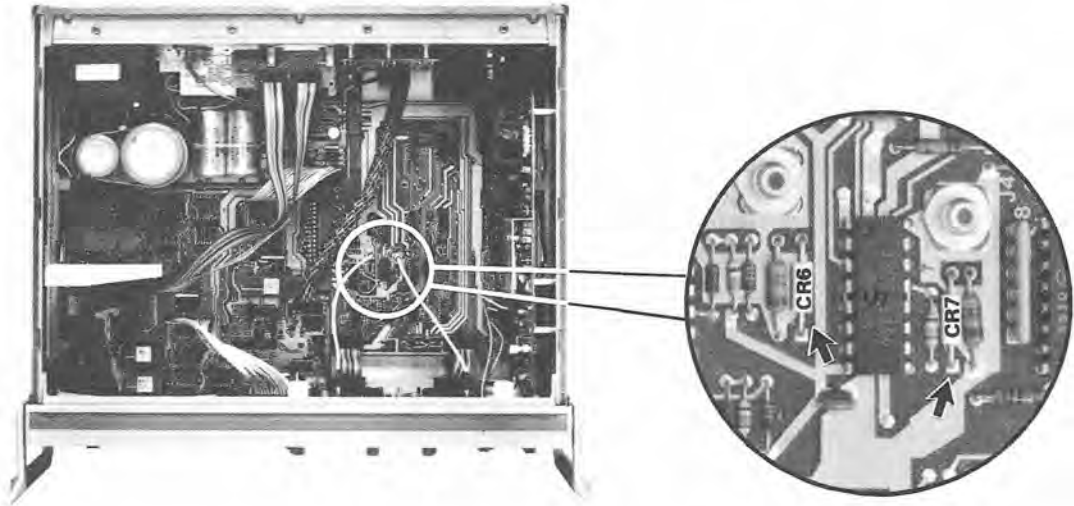

REMOVE 5335A TOP COVER
CONNECT PROBE TO ANODE OF:
CHANNEL A A2CR7 OR
CHANNEL B A2CR6

TOP VIEW

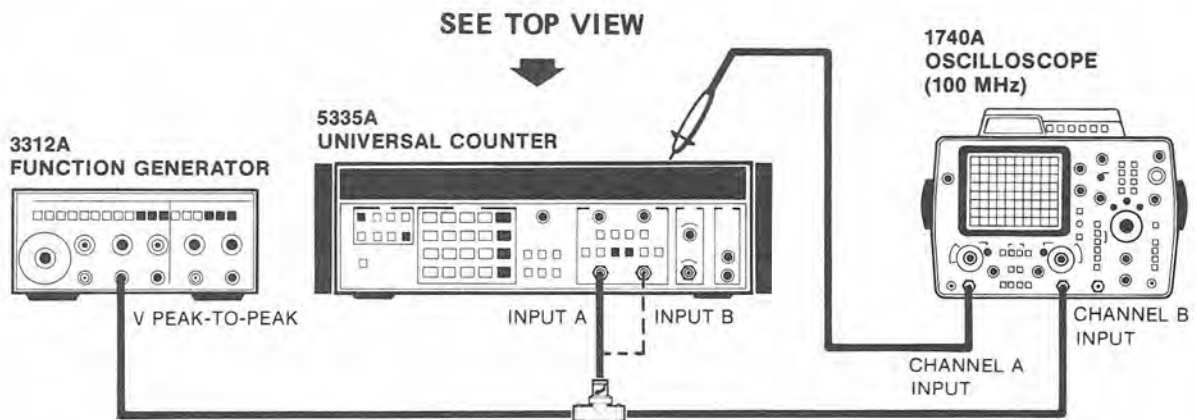

Figure 5-1. Input Amplifier Adjustment Setup.

- d. The 5335A should display 2.985 Vdc (± 50 mV).

CAUTION

After making the power supply adjustments, and in order to provide the proper voltage to the MRC external arm input, REMOVE A6C1.

- e. Connect the positive terminal of the DVM to A1U6(3) or the cathode of A1CR2, and the negative terminal to chassis ground.

- f. Adjust A1R15 for a DVM reading of ^{15.0}~~15.70~~ Vdc (~~± 20 mV dc~~) _{± 100 mV}

- g. Turn off the 5335A, and disconnect the test equipment.

5-13. A3 Input Amplifier Adjustment Procedure

5-14. To perform the Offset and Hysteresis adjustments required for A3, proceed as follows:

- a. Remove the 5335A top cover, and locate variable resistors R37, R47, R88, and R96 on the A3 Input Amplifier Assembly (⁰⁵³³⁵⁻⁶⁰⁰³³~~05335-60003~~). Refer to Assembly Adjustment Locator in ~~Figure 5-1~~ ₈₋₁₀₉ and component locators in Section VIII.

- b. Set the 5335A front panel controls as follows:

GATE TIME Adjust to about 150 ms
 FUNCTION FREQ A
 GATE MODE NORM
 CYCLE NORM
 INPUT (Channels A and B)
 1 M Ω /50 Ω 50 Ω (IN)*
 Trigger Level PRESET
 ATTN X1 (OUT)*
 AC/DC DC (OUT)*
 COM A OUT
 AUTO TRIG OUT
 POWER STBY/ON ON

*In the parenthetical notes such as (IN), the "in" refers to the position of the designated front panel switch.

- c. Set the 3312A Function Generator to output a 1.0 kHz sine wave at ~ 100 mV p-p.

- d. Connect the test equipment as shown in Figure 5-1; for the Channel A adjustment, connect the oscilloscope A channel probe to the junction of A2U11(7) and A2R39.

WARNING

DO NOT SHORT THE PROBE TO ANY OTHER TRACES OR COMPONENTS, OR DAMAGE WILL OCCUR TO THE CIRCUITRY, PARTICULARLY TO THE AMPLIFIER SCHMITT IC'S.

- e. Set the oscilloscope for the X-Y mode, and calibrate by centering the dot at center screen.

- f. Position both A3R96 (offset) and A3R88 (hysteresis) to approximately midrange.

- g. Adjust A3R96 (offset) to position the waveform at the center of the screen. Adjust A3R88 (hysteresis) for 20 mV p-p on the X-axis. Refer to the waveform in Figure 5-2.

- h. Disconnect the oscilloscope A channel probe from A2R39 and connect the probe to the junction of A2U7(12) and A2R32. Disconnect the signal generator output from the 5335A Channel A INPUT and connect it to the Channel B INPUT.

- i. Set the 5335A for Special Function #17; (press: SCALE, SMOOTH, 1, 7, ENTER).

- j. Position both A3R47 (offset) and A3R37 (hysteresis) to approximately midrange.

- k. Adjust A3R47 (offset) to position the waveform at the center of the screen. Adjust A3R37 (hysteresis) for 20 mV p-p on the X-axis. Refer to the waveform in Figure 5-2. This completes the adjustment of Channel A and B; turn the 5335A off and disconnect all test equipment.

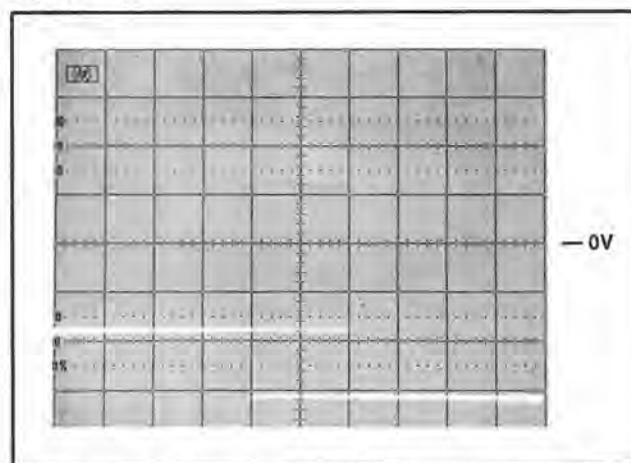

Figure 5-2. Input Amplifier Adjust Waveform *

* A-Channel: 0.05 mV/cm Y-axis (with a 10:1 probe)

* B-Channel: 0.01 mV/cm X-axis

5-15. A8 Digital Voltmeter (Option 020) Adjustment Procedure

5-16. To perform the adjustments required for the DVM, proceed as follows:

- a. Turn on 5335A and allow instrument (and voltmeter) to warm-up for 20 minutes.

NOTE

The following adjustments are sequential and should be performed in the order indicated.

- b. Set the 5335A to the VOLTS function, and adjust the GATE TIME for ~150 ms.

- c. Short the DCV-COM VOLTS module inputs together, to force the DVM into the 10 μ V resolution range.

- d. Press DISABLE, N=1000 to get an additional two digits of display. Connect the HP 3455A negative (Low) lead to the "floating" ground (COM) on A8. Connect the positive (Hi) lead to A8TP1; the reading on the multimeter should be 0V ($\pm 5 \mu$ V). If not, adjust A8 "Zero Offset" for 0V ($\pm 5 \mu$ V).

- e. Remove the short between the DCV-COM inputs of the VOLTS module. Set the DC Standard to 4.0000 volts, and connect it to the VOLTS module input. Observe and record the 5335A display. Reverse the polarity of the input voltage, and observe and record the negative display. Take the sum of the absolute values of the two readings, and divide-by-two. Adjust "REF SYM" for a display of that calculated value.

- f. Adjust "Low V" until the 5335A displays 4.0000V ($\pm 100 \mu$ V).

- g. Set the DC Standard to 40.000 volts. Adjust "Med V" for a display of 40.000V (± 1 mV).

WARNING

THE FOLLOWING STEP REQUIRES HIGH VOLTAGE. EXTREME CARE SHOULD BE EXERCISED.

- h. Set the DC Standard to 400.000 volts. Adjust "High V" for a display of 400.00V (± 10 mV).

- i. Return the DC Standard to 4.000 volts, then turn the DC Standard and the 5335A off; disconnect all test equipment.

5-17. A9 Channel C (Option 030) Adjustment Procedure

5-18. To perform the adjustments required for the CHANNEL C, proceed as follows:

- a. Turn on 5335A and allow instrument (and CHANNEL C) to warm-up for 5 minutes.

- b. Remove the instrument top cover and locate variable resistors R22 (L), R23 (H), and R24 (K) on the A9 Channel C Assembly (05335-60009). Refer to the A9 component locator in Section VIII.

- c. Set the 5335A front panel controls as follows:

GATE MODE NORM
GATE CYCLE NORM
GATE TIME to about 1.2 s
FUNCTION FREQ C
INPUT C Sensitivity MAX
(no input signal)

(SELF OSCILLATING ADJUSTMENT)

- d. Set A9R22 (L) to full clockwise position, and adjust A9R23 (H) until the 5335A displays 1010 MHz (± 10 MHz).

- e. Adjust A9R24 (K) for maximum display of frequency. Readjust A9R23 (H) for a display of 1010 MHz (± 10 MHz). Steps d and e may have to be repeated.

(SENSITIVITY ADJUSTMENT)

- f. Connect the instrument as shown in *Figure 5-3*.

- g. Adjust the Channel C front panel SENSITIVITY control to MAX (fully clockwise).

- h. Set A9R22 (L pot) fully counterclockwise.

- i. Set the 8660C to output a 1 GHz sinewave, varying the 86603A vernier until the HP 436A Power Meter reads -24 dBm, ± 0.3 dBm. Adjust A9R22 ("L" pot) clockwise slowly until the 5335A displays 1 GHz (± 1 Hz).

- j. Set the 5335A GATE TIME to about 1.5 seconds.

- k. Set the 8660C to output 1.3 GHz sinewave, varying the 86603A vernier until the HP 436A power meter reads -13 dBm (-19 dBm, 25 mV rms at the 5335A input). Verify that the counter displays 1.300 000 000 +9 (± 1 Hz).

- l. Turn the 5335A and 8660C off, and disconnect all test equipment.

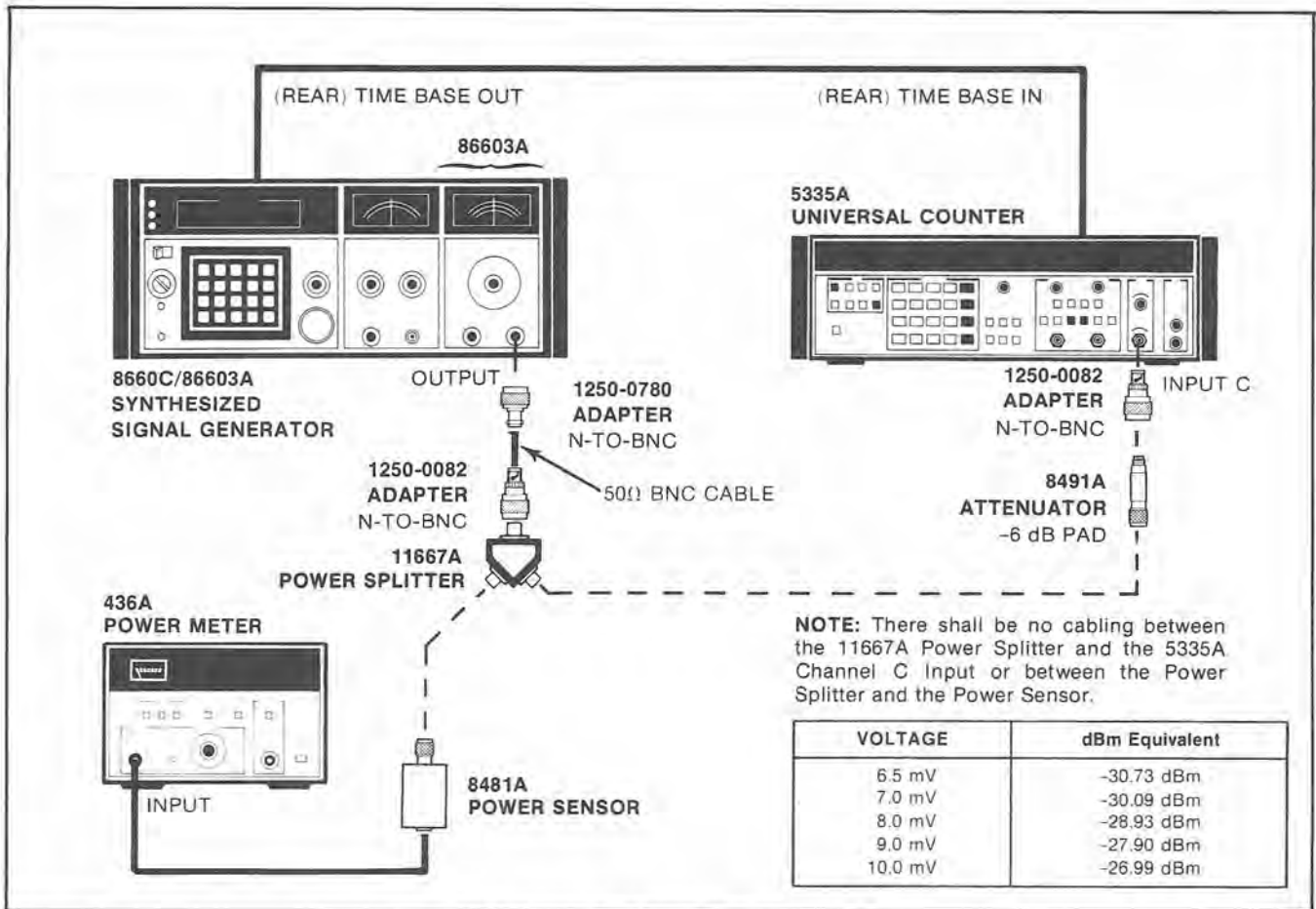

Figure 5-3. Channel C Sensitivity Adjustment Setup

5-19. Oscillator Adjustment Procedure (Local and Option 010)

5-20. Every few months, the oscillator should be checked to a house standard. When adjustment is required, use the oscilloscope method shown below. When checking the optional oven oscillator, Option

010, allow a 24-hour warmup period before adjustment. To perform the oscillator adjustment, proceed as follows:

- a. As shown in *Figure 5-4*, connect a reference frequency standard to the external sync input of the oscilloscope.

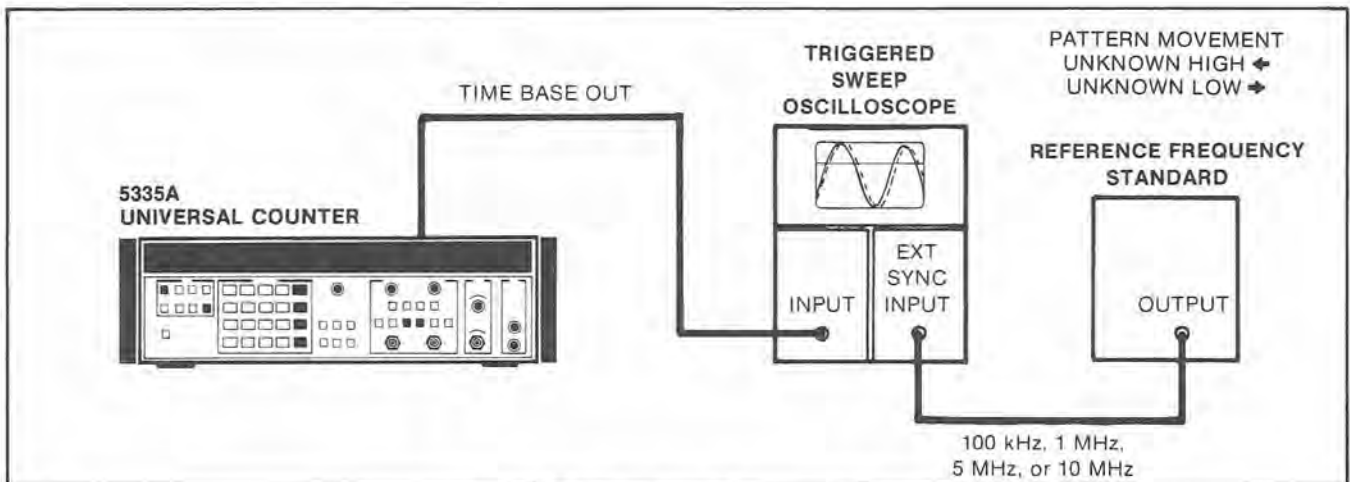

Figure 5-4. Oscillator Adjustment Setup

b. Connect rear panel TIME BASE OUT of the 5335A to Channel A of the scope.

c. Adjust the oscillator frequency for the minimum sideways movement of the 10 MHz displayed signal. For the local oscillator, adjust A4C6; for Option 010, HP 10544A/10811A Oven Oscillator, adjust the screwdriver adjustment labeled FREQ ADJ.

d. By timing the sideways movement (in centimetres persecond), the approximate frequency offset can be determined based on the oscilloscope sweep speed as shown in Table 5-2.

5-21. A2 Channel A and B Level Shifter Adjustment Procedure

5-22. To perform the adjustments required for the A2 Level Shifter proceed as follows:

a. Remove the 5335A top cover and locate variable resistors R65 and R66 on the A2 Amplifier Support Assembly (05335-60002).

b. Connect the 8640B Signal Generator, RF OUTPUT to 5335A INPUT A, and the 8640B TIME BASE OUT to 5335A TIME BASE IN as shown in Figure 5-5.

c. Set the 5335A front panel controls as follows:

- FUNCTION PER A
- GATE MODE NORM
- CYCLE NORM
- INPUT (Channels A and B)
- SLOPE (negative)
- 1 MΩ/50Ω 50Ω (IN)
- TRIGGER LEVEL PRESET (OUT)
- X1/X10 ATTN X1 (OUT)
- AC/DC DC
- COM A OUT
- AUTO TRIG OUT

d. Set the 8640B to output a 110 MHz signal at 15 mV rms.

NOTE

8640B amplitude may be increased up to 20 mV rms if necessary, to obtain stable count within ±2 Hz.

Table 5-2. Frequency Offset Estimation

| MOVEMENT | SWEEP SPEED | | | NOTES |
|------------|----------------------|----------------------|-----------------------|--|
| | 1 μs/cm | 0.1 μs/cm | 0.01 μs/cm | |
| 1 cm/s | 1 × 10 ⁻⁶ | 1 × 10 ⁻⁷ | 1 × 10 ⁻⁸ | TIME SCOPE TRACE MOVEMENT WITH SECOND HAND OF WATCH OR CLOCK |
| 1 cm/10 s | 1 × 10 ⁻⁷ | 1 × 10 ⁻⁸ | 1 × 10 ⁻⁹ | |
| 1 cm/100 s | 1 × 10 ⁻⁸ | 1 × 10 ⁻⁹ | 1 × 10 ⁻¹⁰ | |

For example, if the trace moves 1 centimetre in 10 seconds and the sweep speed is 0.01 μs/cm, the oscillator signal is within 1 × 10⁻⁹ of the reference frequency.

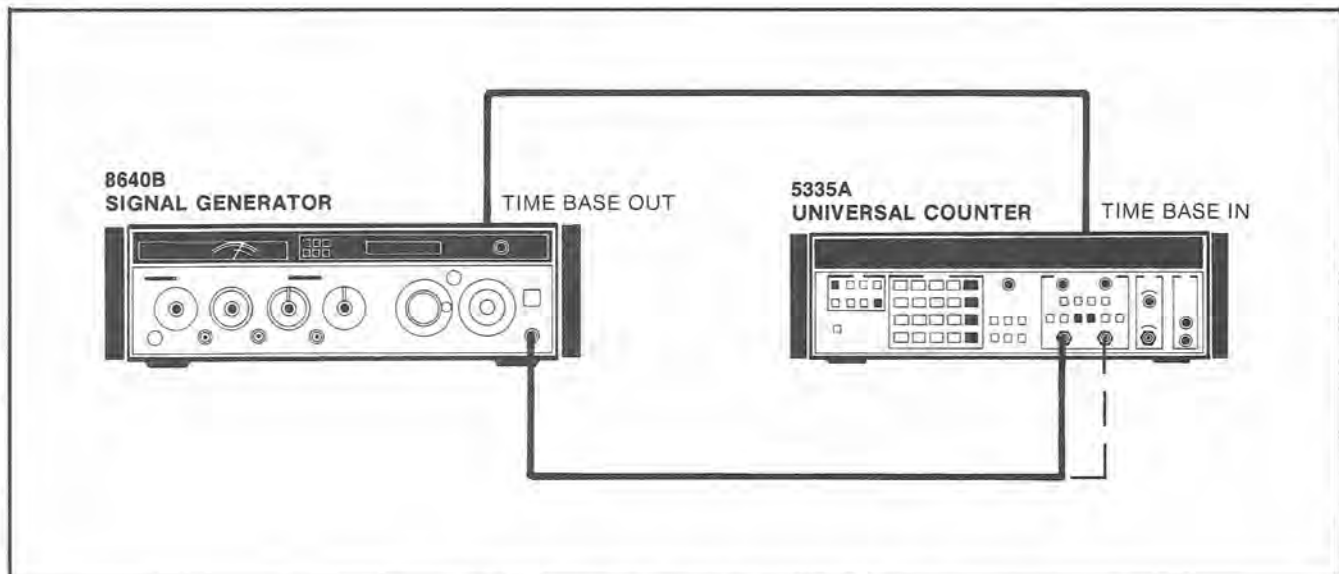

Figure 5-5. Level Shifter Adjustment Set-Up

e. Press the 5335A GATE TIME key and adjust the GATE ADJ knob to where the 5335A display shows 300 milliseconds. (± 50 ms). Press the 5335A RESET key to return the function to PER A. Verify the PER A key lamp is ON.

f. Adjust A2R66 for Channel A to where the 5335A display remains stable at 9.0909091 ns within ± 2 counts.

NOTE

It may be necessary to vary the GATE ADJ knob to obtain the required resolution (i.e., 9.090909X).

g. Set Channel A slope to (F) positive and adjust A2R66 to where the count is stable within ± 2 counts. Display should be stable to within ± 2 counts on both slopes (ㄨ and F).

h. Connect the 8640B Signal Generator to 5335A INPUT B. Ensure the 8640B is set to output a 110 MHz signal at 15 mV rms.

i. Set the 5335A to Special Function 17, by pressing: SCALE, SMOOTH, 1, 7, ENTER.

j. For Channel B adjust A2R65 for a 5335A stable display of 110 MHz ± 1 Hz on both negative slope (ㄨ) and positive slope (F). This completes the Channel A and B level shifter adjustment.

k. Disconnect all test equipment.

5-23. Channel A and B Peak Detector Adjustment Procedure

5-24. To perform the Peak Detector adjustments required for the A3 assembly proceed as follows:

a. Remove the 5335A top cover, and locate variable resistors R99, R100, R101, and R102 on the A3 Amplifier Buffer Assembly (05335-60003).

b. Set the 5335A front panel controls as follows:

- FUNCTION FREQ A
- INPUT (CHANNELS A AND B)
- 1 M Ω /50 Ω 50 Ω (IN)
- ATTN X1 (OUT)
- AC/DC DC (OUT)
- AUTO TRIG ON (IN)
- COM A ON (IN)
- TRIGGER LEVEL POTS CCW
(but not in PRESET)

Channel A Peak Detector Adjustment

c. Connect a Function Generator (HP 3312A) to Input A; set the function generator to output a ~~200 Hz square wave at 500 mV p-p.~~ *30 HZ SINEWAVE AT 5V P-P*

d. Connect the DVM (HP 3455A) positive input to either side of A3R54 (422 ohms) and the DVM negative input to the ground test pin on A3.

e. Adjust A3R100 ("-PK") so that the DVM displays ~~-240 mV \pm 5 mV.~~ *2.44 V +/- 10 mV*

f. Rotate Channel A Trigger Level Pot to the CW position; adjust A3R99 ("PK") so that the DVM displays ~~+24 mV \pm 5 mV.~~ *2.44 V +/- 10 mV*

Channel B Peak Detector Adjustment

g. ~~Connect a Function Generator (HP 3312A) to Input B; set the function generator to output a 200 Hz square wave at 500 mV p-p.~~ *30 HZ SINEWAVE AT 5V P-P*

h. Connect the DVM (HP 3455A) positive input to either side of A3R38 (422 ohms) and the DVM negative input to the ground test pin on A3.

i. Adjust A3R102 ("-PK") so that the DVM displays ~~-240 mV \pm 5 mV.~~ *2.44 V +/- 10 mV*

j. Rotate Channel B Trigger Level Pot to the CW position; adjust A3R101 ("PK") so that the DVM displays ~~+240 mV \pm 5 mV.~~ *2.44 V +/- 10 mV*

NOTE

If one Peak Detector can be adjusted to ± 240 mV, the other Peak should be adjusted to that same magnitude with opposite polarity, in order to maintain symmetry. If the Peak Detectors cannot be adjusted into the permissible range, a 3.16 M Ω resistor (P/N 0699-0070) may be installed in place of the 4.64 M Ω resistor. Use the following table to determine which resistor to change:

| Magnitude of Peak | Channel A | | Channel B | |
|-------------------|-----------|-------|-----------|-------|
| | +Peak | -Peak | +Peak | -Peak |
| Too High | R89 | R92 | R1 | R10 |
| Too Low | R90 | R91 | R2 | R11 |

5-25. A6 Rear Panel Assembly Adjustment Procedure

NOTE

The following procedure can ONLY be used to adjust Part Number 05335-61006, A6 board.

5-26. Use the following procedure to adjust the External Arm circuitry in A6 rear panel assembly, part number 05335-61006. This is the only adjustment in the A6 assembly.

a. Set the 5335A front and rear panel controls as follows:

| | |
|---------------------------|--------------------|
| FUNCTION | GATE TIME |
| EXTERNAL ARM (Rear panel) | |
| START switch | Positive edge (UP) |
| STOP switch | Positive edge (UP) |

b. Enable the EXT ARM ENABLE Function and the CYCLE MIN on the 5335A front panel. With no signal applied to the EXTERNAL ARM IN, observe that the GATE TIME, EXT ARM ENABLE, GATE MODE MIN, and CYCLE MIN LED's are ON; also the GATE LED is not flashing.

c. Connect the 5335A rear panel GATE OUT connector to the 1740A oscilloscope INPUT A and the 3325A Synthesizer/Function Generator to the 5335A EXTERNAL ARM IN connector (through a 50Ω feed-through) as shown in Figure 5-6.

d. Set the HP 3325A to output a 3-volt peak-to-peak square wave with an offset of +1.5 volt, at a frequency of 100 Hz.

e. Set the 5335A EXTERNAL ARM ADJ (through the rear panel) to full clockwise position. This will set the External Arming circuitry for TTL level signals.

f. Observe that the 5335A displays about 10 ms. Also, the 1740A display shows a 10 ms negative TTL pulse, indicating that the gate is being armed by the 100 Hz signal into the EXTERNAL ARM IN.

g. Turn off and disconnect all test equipment.

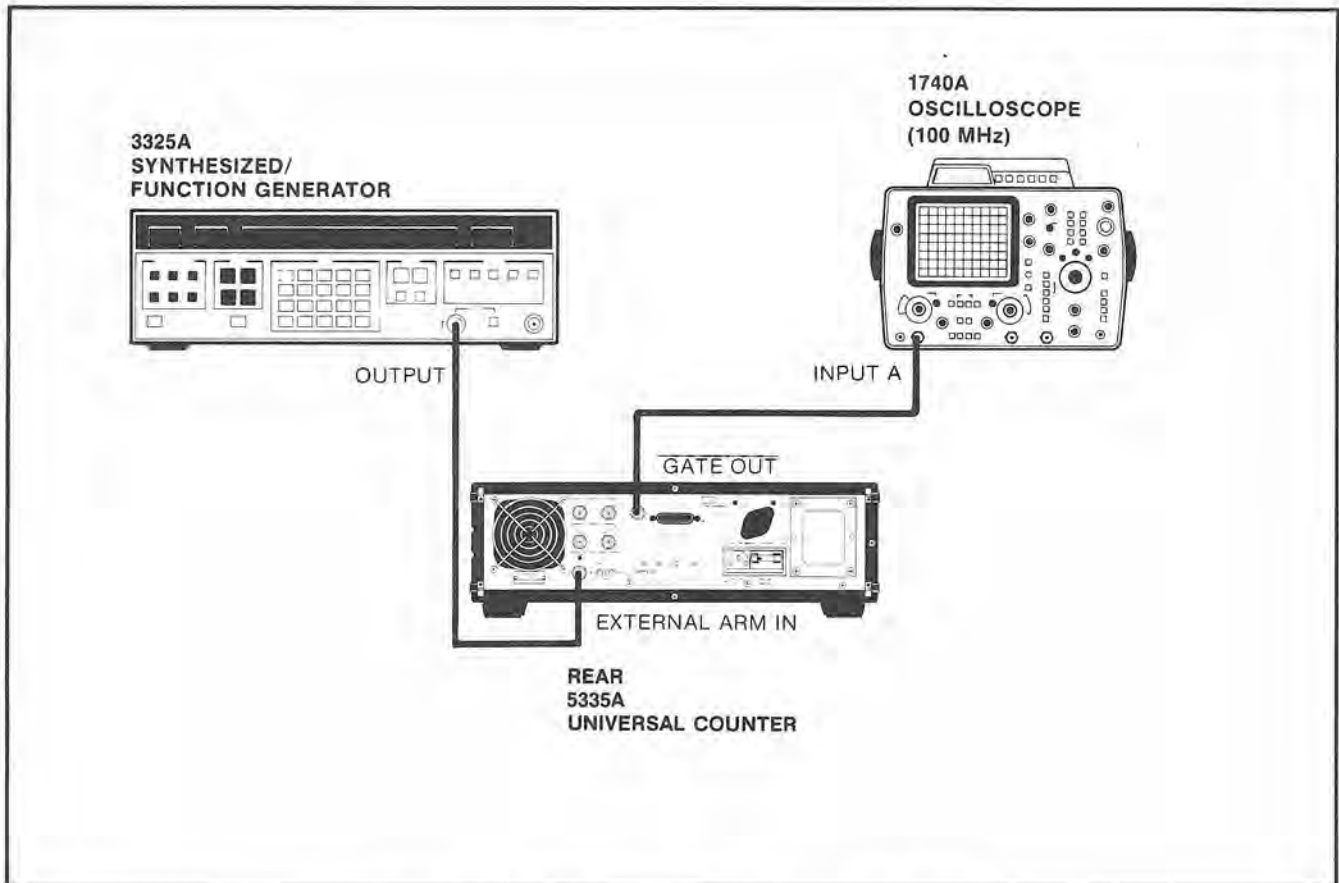

Figure 5-6. A6 Rear Panel Assembly Adjustment Setup

5-27. OPTION 040 ADJUSTMENT PROCEDURES

5-28. The following procedures can be used for adjusting the HP 5335A Universal Counter with Option 040. They cover the adjustments for the Input Amplifiers and Peak Detectors on the A12 board, and the Digital-to-Analog Converters (DAC's) and the attenuators on the A11 board. These are the only adjustments that differ from the standard 5335A adjustment.

5-29. A12 Programmable Input Amplifier (Option 040) Adjustment Procedure

5-30. To perform the Offset and Hysteresis adjustments required for A12, proceed as follows:

a. Remove the 5335A top cover, and locate variable resistors R43, R53, R110, and R105 on the A12 Programmable Input Amplifier Assembly (05335-60012). Refer to Assembly Adjustment Locator in Figure 5-7, and corresponding component locators.

b. Set the 5335A front panel controls as follows:

GATE TIME . Adjust to about 150 ms
 FUNCTION FREQ A
 GATE MODE NORM
 CYCLE NORM
 INPUT (Channels A and B)
 1 MΩ/50Ω 50Ω (H) (LITE ON)
 TRIGGER LEVEL ... PRESET (~~OFF~~)
 ATTN X1 (~~OFF~~) (LITE OFF)
 AC/DC DC (LITE OFF)
 COM A ~~OFF~~ OFF (LITE OFF)
 AUTO TRIG ~~OFF~~ OFF (LITE OFF)
 POWER STBY/ON ON

c. Set the 3312A Function Generator to output a 1.0 kHz sine wave at ~100 mV p-p.

d. Connect the test equipment as shown in Figure 5-7; for the Channel A adjustment, connect the oscilloscope Channel A probe to the junction of A11R47 and R54.

WARNING

DO NOT SHORT THE PROBE TO ANY OTHER TRACES OR COMPONENTS, OR DAMAGE WILL OCCUR TO THE CIRCUITRY, PARTICULARLY TO THE AMP SCHMITT IC'S.

e. Set the oscilloscope for the X-Y mode, and calibrate by centering the dot at center screen.

f. Position both A12R105 (offset) and A12R110 (hysteresis) to approximately midrange.

g. Adjust A12R105 (offset) to position the waveform at the center of the screen. Adjust A12R110 (hysteresis) 20 mV p-p on the X-axis. Refer to the waveform in Figure 5-8.

h. Disconnect the oscilloscope Channel A probe from junctions of A11R54 and R47 and connect the probe to the junction of A11R37 and R38. Disconnect the signal generator output from the 5335A Channel A INPUT and connect it to the Channel B INPUT.

i. Set the 5335A for Special Function #17; (press: SCALE, SMOOTH, 1, 7, ENTER).

j. Position both A12R53 (offset) and A12R43 (hysteresis) to approximately midrange.

k. Adjust A12R53 (offset) to position the waveform at the center of the screen. Adjust A12R43 (hysteresis) for 20 mV p-p on the X-axis. Refer to the waveform in Figure 5-8. This completes the adjustment of Channels A and B; turn the 5335A off and disconnect all test equipment.

Table 5-3. Option 040 Adjustments

| Procedure | Assemblies | Adjustments | Comments |
|------------------------------|------------|---------------------------------|--|
| Input Amplifier | A12 | A12R43, R53, R110, R105 | Uses Special Function #17 |
| Peak Detectors | A12 | A12R107, R111, R2, R21 | Perform adjustments in indicated order |
| Digital-to-Analog Converters | A11 | A11R74, R75, R70, R69, R48, R53 | Uses Special Function #18 and #19 |
| Attenuators | A12 | A12C46, C30 | Perform adjustments in indicated order |

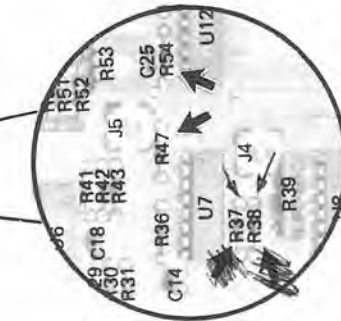
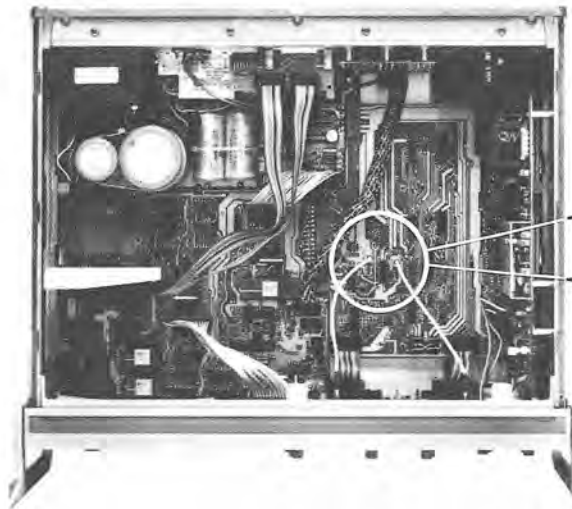

REMOVE 5335A TOP COVER
CONNECT PROBE TO JUNCTION OF:
CHANNEL A ... A11R47 & R54
CHANNEL B ... A11R37 & R38

TOP VIEW

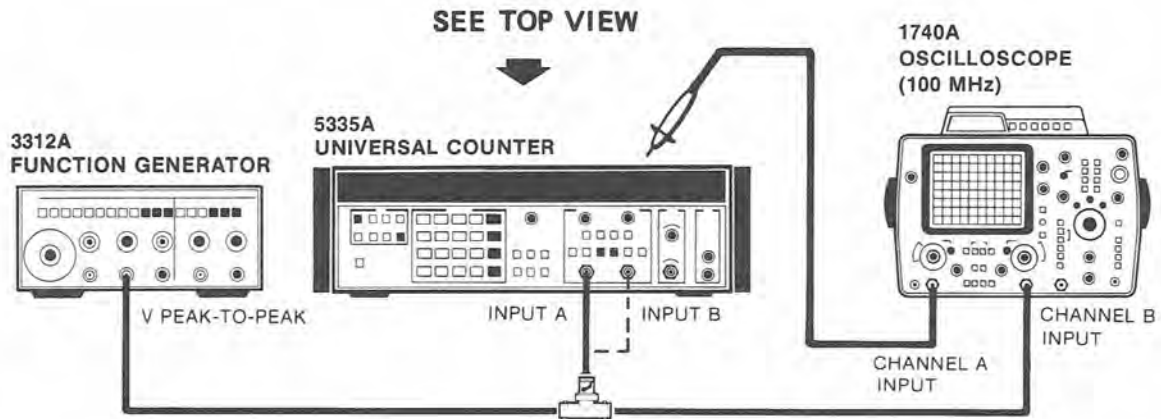

Figure 5-7. Programmable Input Amplifier Adjustment Setup

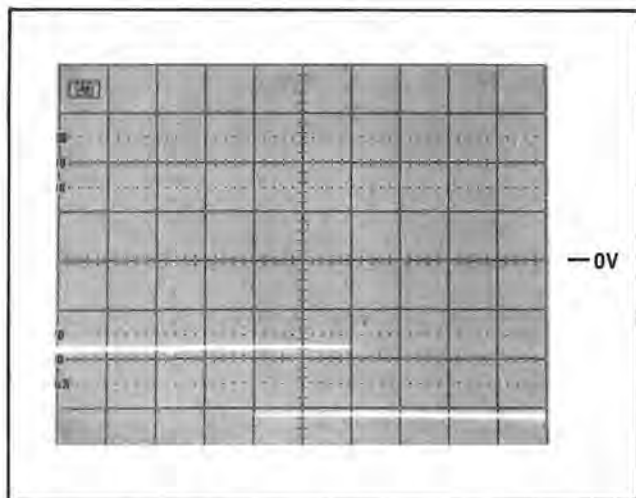

Figure 5-8. Input Amplifier Adjustment Waveform*

- *Channel A: 0.05 ~~mV~~ V/cm Y-axis (with a 10:1 probe)
- *Channel B: 0.01 ~~mV~~ V/cm X-axis

5-31. A12 Peak Detectors Adjustment Procedure

5-32. To perform the Peak Detector adjustments required for the A12 assembly proceed as follows:

- a. Remove the 5335A top cover, and locate variable resistors R107, R111, R2, and R21 on the ~~A21~~ A12 Programmable Input Amplifier Assembly (05335-60012).
- b. Connect the test equipment as per Figure 5-8. ⁵⁻¹¹
- c. Set the 5335A front panel controls as follows:

FUNCTION FREQ A
 INPUT (Channels A and B)
 1 MΩ/50Ω 50Ω ~~(LITE ON)~~
 ATTN X1 ~~(LITE OFF)~~
 AC/DC DC ~~(LITE OFF)~~
 AUTO TRIG ON ~~(LITE ON)~~
 COM A ON ~~(LITE ON)~~
 TRIGGER LEVEL POTS CCW
 (but not in PRESET)

- d. Set the HP 3312A Function Generator to output a ~~200 Hz square wave at 500 mV p-p.~~
^{30 HZ SINEWAVE AT 5V P-P}

CHANNEL A:

- e. Connect the HP 3455A DVM positive input to A11 (ATL) test point and the DVM negative input to the "GAA" test point.

f. Adjust A12R~~111~~ ^{R111} ("PK") so that DVM displays ~~240 mV ± 5 mV.~~ ^{(-) 2.44V ± 10 mV}

g. Rotate Channel A Trigger Level Pot to the CW position; adjust A12R~~107~~ ^{R107} ("PK") so that DVM displays ~~240 mV ± 5 mV.~~ ^{+ 2.44V ± 10 mV}

CHANNEL B:

- h. Connect the HP 3455A DVM positive input to A11 "BTL" test point and the DVM negative input to the "GAB" test point.

i. Adjust A12R21 ("PK") so that DVM displays ~~240 mV ± 5 mV.~~ ^{(-) 2.44V ± 10 mV}

j. Rotate Channel B Trigger Level Pot to the CW position; adjust A12R2 ("PK") so that DVM displays ~~240 mV ± 5 mV.~~ ^{(-) 2.44V ± 10 mV}

NOTE

~~If one Peak Detector can be adjusted to ±240 mV, the other Peak Detector should be adjusted to that same magnitude with opposite polarity, in order to maintain symmetry. If the Peak Detectors cannot be adjusted into the permissible range, a 3.16 MΩ resistor (P/N 0699-0070) may be installed in place of the 4.64 MΩ resistor. Use the following table to determine which resistor to change:~~

SEE CHANGE 4/25/85
CANNOT
(-) 2.44V ± 10 mV

| MAGNITUDE OF PEAK | CHANNEL A | | CHANNEL B | |
|-------------------|-----------|-------|-----------|-------|
| | +PEAK | -PEAK | +PEAK | -PEAK |
| TOO HIGH | R100 | R101 | R7 | R16 |
| TOO LOW | R106 | R108 | R8 | R17 |

- k. Turn off 5335A and all test equipment; also, disconnect all test equipment.

5-33. A12C46 Adjustment Procedure

- a. Connect power cable to the 5335A; switch the line power from STBY to ON.
- b. Connect the HP 8654A Signal Generator to the 5335A INPUT A as shown:

SEE CHANGE 4/25/85

MANUAL CHANGES MODEL 5335A (05335-90021)

 SERIAL PREFIX OR
 SERIES NUMBER

 CHANGES

Page 5-11. Adjustments:**5-33. A12C46 Adjustment Procedure:**

- a. Connect power cable to the 5335A; switch the line power from STBY to ON.
- b. Connect the HP3312A Function Generator to the 5335A INPUT A.
- c. Set the 5335A front panel controls as follows:

| | |
|---------------------|-------------|
| FUNCTION | RISE/FALL A |
| GATE ADJ | fully CCW |
| INPUT (Chan A) | |
| 1 Meg/50 ohm | 50 ohm (ON) |
| TRIGGER LEVEL | PRESET |
| X10/X1 ATTN | X1 (OFF) |
| AC/DC | DC (OFF) |
| FILTER | (OFF) |
- d. Set the 3312A Function Generator to output a 50 Hz squarewave at 5 volts p-p. Make a note of the measurement value displayed by the 5335A.
- e. Set the 5335A Channel A ATTENUATOR TO X10.
- f. Locate variable capacitor A12 C46.
- g. Adjust A12 C46 so that the 5335A display is the same as the value noted in step "d", (+0/-3 nanoseconds).

5-34. A12C30 Adjustment Procedure

- a. Switch the 5335A line power from ON to OFF, then back to ON.
- b. Connect the HP8654A Signal Generator to the 5335 INPUT A, as shown in Figure 5-9.

 SERIAL PREFIX OR
 SERIES NUMBER

 CHANGES

Page 5-11. Adjustments:

c. Set the 5335A front panel controls as follows:

| | |
|-----------------------------|----------------|
| FUNCTION | FREQ A |
| MATH MATCH | OFF (LEDS OFF) |
| STATISTICS | OFF (LEDS OFF) |
| GATE MODE | NORM |
| CYCLE | NORM |
| GATE ADJ | fully CCW |
| INPUT (Chan A) | |
| 1 Meg/50 ohm | 50 ohm (ON) |
| TRIGGER LEVEL | PRESET |
| X10/X1 ATTN | X1 (OFF) |
| AC/DC | AC (ON) |
| FILTER | (OFF) |
| COM | (OFF) |

e. Set the 8654A Signal Generator to output a 100 MHz sinewave at a minimum output level on the 30 mV range. Increase the output level until the 5335A displays a stable count of "100 MHz". Record this signal level as "CHAN A, X1 = xx mV", and save for step "g".

f. Set the 5335A Channel A ATTENUATOR to X10 (on). Change the 8654A output range to the 300mV scale (10 times output level of step "e"). Increase the output level until the 5335A displays a stable count of "100 MHz". Record this signal level as "CHAN A, X10 = xxx mV", and save for step "g".

g. Divide the value of recorded level from step "f" by recorded level from step "e", to determine the actual attenuation factor of CHAN A. Result should be approximately "10". Record this value as "CHAN A ATTN FACTOR= xx", and save for step "1".

h. Press: SCALE, SMOOTH, 1,7, ENTER. This will enable special function FREQ B.

i. Set the 5335A front panel controls as follows:

| | |
|---------------------|-------------|
| INPUT (Chan B) | |
| 1 Meg/50 ohm | 50 ohm (ON) |
| TRIGGER LEVEL | PRESET |
| X10/X1 ATTN | X1 (OFF) |
| AC/DC | AC (ON) |
| FILTER | (OFF) |
| COM | (OFF) |

j. Connect the 8654A Signal Generator to the 5335A INPUT B, as shown in Figure 5-10.

MANUAL CHANGES MODEL 5335A (05335-90021)

 SERIAL PREFIX OR
 SERIES NUMBER

 CHANGES

Page 5-11. Adjustments:

k. Set the 8654A Signal Generator to output a 100 MHz sinewave at the minimum output level on the 30 mV range. Increase the output level until the 5335A displays a stable count of "100 MHz". Record the signal level as "CHAN B, X1 = xx mV", and save for step "1".

l. Multiply the value of recorded level from step "k" by the factor determined in step "g".

m. Set the 5335A Channel B ATTENUATOR to X10 (on). Change the 8654A output range to the 300mV scale (10 times output level of step "e"), and adjust the level as close as possible to the value determined in step "l".

n. Locate variable capacitor A12 C30.

o. Adjust A12 C30 so that the 5335A display just gives a stable count of 100 MHz.

2336

Paragraph 5-32, step a:

>Change Part Number of A12 Programmable Input Amplifier Assembly from 05335-60012 to 05335-60032.

Page 5-13. Adjustments:

All Serials

Paragraph 5-36, step a:

>Add "R48 (A) and R53 (B)." to the list of variable resistors in step a.

Paragraph 5-36, step b:

>Delete the first sentence "Repeat step 5-32(e)" and replace with "Connect the HP3455A DVM positive input to A11 (ATL) test point and negative input to A11 (GAA) test point."

Paragraph 5-36, step f:

>Change step "f." to "g."

>Add step f:

"All Level Shift resistors R48 and R53 are adjusted exactly as A2 Level Shift resistors A2R65 and R66. To adjust the A11 Level Shift resistors, follow the procedure listed in paragraph 5-21, substituting R53 for R66 and R48 and R65 in the instructions."

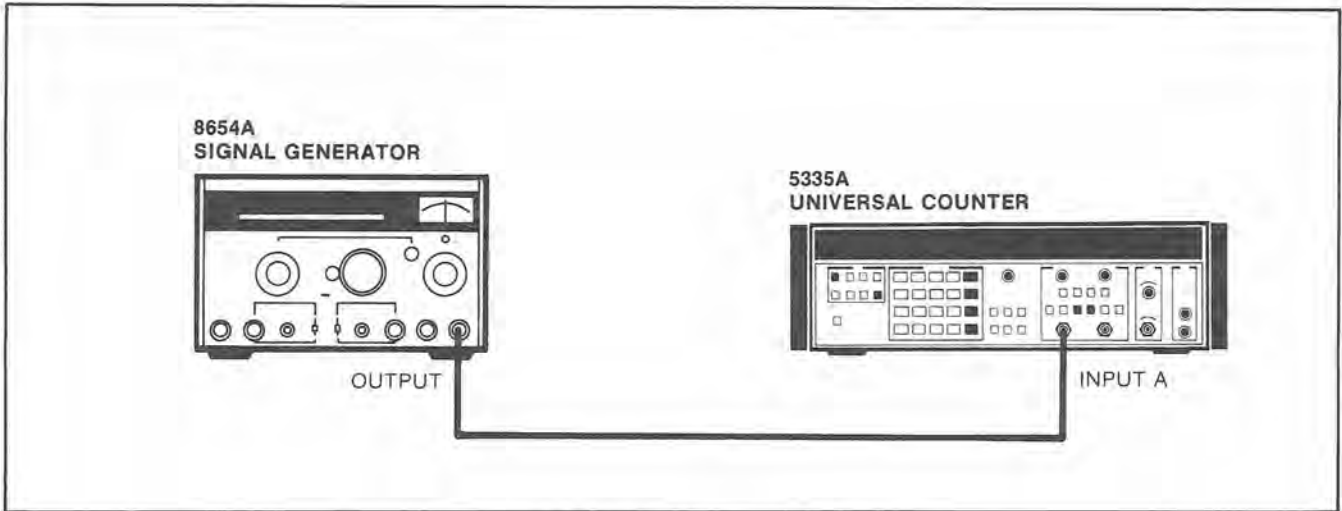

Figure 5-9. A12C46 Adjustment Setup

*REPLACE
SEE CHANNEL
4/25/85*

c. Set the 5335A front panel controls as follows:

- GATE ADJ fully CCW
- INPUT (Channel A)
- 1 M Ω /50 Ω 50 Ω (ON)
- TRIGGER LEVEL PRESET
- X10/X1 ATTN X1 (OFF)
- AC/DC AC (ON)
- FILTER (OFF)
- COM A (OFF)

g. Locate variable capacitors A12C46 and C30 on the 05335-60012 Assembly.

h. Adjust A12C46 so that the 5335A display just gives a stable count of 100 MHz.

NOTE

This adjustment must be performed very carefully in order to obtain the desired results.

d. Set the 8654A to output a 100 MHz sine wave at a minimum output level on the 30 mV range. Increase the output level of the 8654A until the 5335A displays a stable count of 100 MHz. Record this level.

e. Set the 5335A Channel A Attenuator to **X10 (ON)**, and COM A momentary switch to **ON**. Set the 8654A output range to the 300 mV scale.

f. Set the 8654A to output a level 10 times the previously recorded level in step d.

5-34. A12C30 Adjustment Procedure

a. Switch the 5335A line power from ON to OFF, then back to ON.

b. Press: SCALE, SMOOTH, 1, 7, ENTER. This will enable special function Frequency B.

c. Connect the HP 8654A Signal Generator to the 5335A INPUT B as shown:

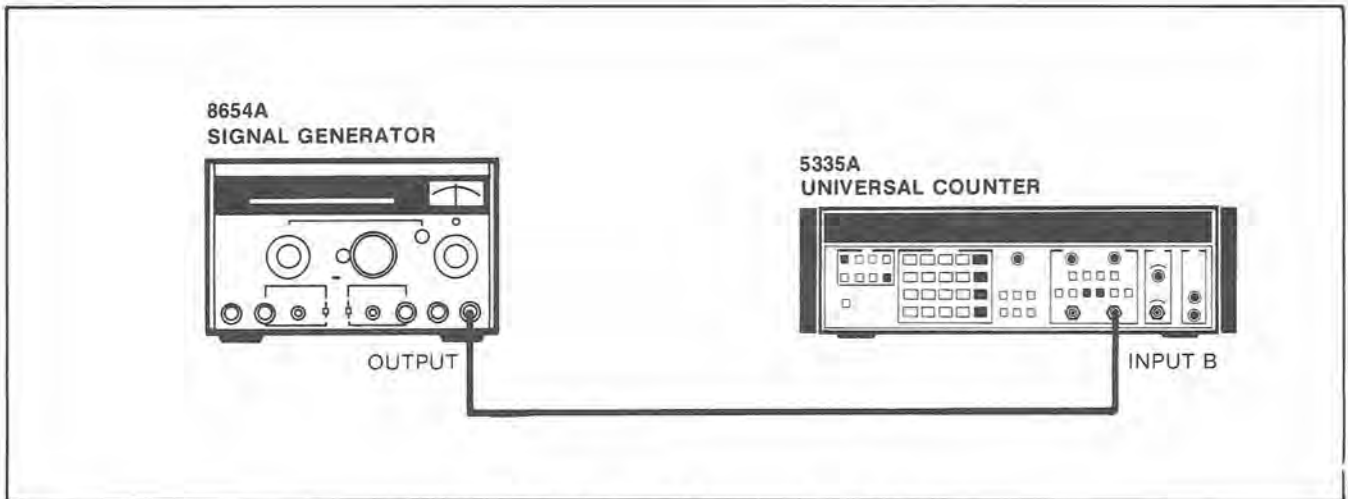

Figure 5-10. A12C30 Adjustment Test Setup

REPLACE
SEE CHANNEL
A/27/85

d. Set the 5335A front panel controls as follows:

- MATH Off (LEDs off)
- STATISTICS Off (LEDs off)
- GATE MODE NORM
- CYCLE NORM
- GATE ADJ fully CCW
- INPUT (Channel B)
- 1 M Ω /50 Ω 50 Ω (ON)
- TRIGGER LEVEL PRESET
- X10/X1 ATTEN X1 (OFF)
- AC/DC AC (ON)
- FILTER (OFF)
- COM A (OFF)

- e. Set the 8654A to output a 100 MHz sine wave at a minimum output level on the 30 mV range. Increase the output level of the 8654A until the 5335A displays a stable count of 100 MHz. Record this level.
- f. Set the 5335A Channel B Attenuator to **X10 (ON)**. Set the 8654A output range to the 300 mV scale.
- g. Set the 8654A to output a level 10 times the previously recorded level in step e.
- h. Adjust A12C30 so that the 5335A display just gives a stable count of 100 MHz.
- i. Replace top cover on the 5335A.

5-35. A11 DAC Adjustment Procedure

5-36. To perform the DAC adjustments required on the A11 assembly, proceed as follows:

- a. Remove the 5335A top cover, and locate variable resistors R74 (A0), R75 (-5.12 "A"), R70 (B0), and R69 (-5.12 "B"), R48 (A), R53 (B)
CONN. DVM+ TO ALL (ATL) AND DVM- TO ALL (GAA)
- b. ~~Repeat step 5-31e.~~ Press: SCALE, SMOOTH, 9, 9, ENTER; wait 5 seconds then press: SCALE, 1, 8, ENTER. Adjust R74 (A0) so that DVM displays 0V \pm 1 mV.
- c. Disconnect DVM positive probe from "ATL" test point and connect the probe to "BTL" test point; also connect DVM negative terminal to "GAB". Vary R70 (B0) for a DVM reading of 0V \pm 1 mV.
- d. Press: SCALE, 1, 9, ENTER. Vary R69 (-5.12 "B") so that DVM displays -5.12 \pm 1 mV.
- e. Disconnect DVM positive terminal from "BTL" test point and connect the terminal to "ATL" test point; also connect DVM negative terminal to "GAA". Vary R75 (-5.12 "A") for a DVM reading of -5.12V \pm 1 mV.
- f. Turn the 3455A and the 5335A off; disconnect all test equipment.

f. ALL LEVEL SHIFT RESISTORS R48 AND R53 ARE ADJUSTED EXACTLY AS A2 LEVEL SHIFT RESISTORS A2R65 AND R66. TO ADJUST THE ALL LEVEL SHIFT RESISTORS, FOLLOW THE PROCEDURE LISTED IN PARA. 5-21, SUBSTITUTION R53 FOR R66, AND R48 FOR R65 IN THE INSTRUCTIONS

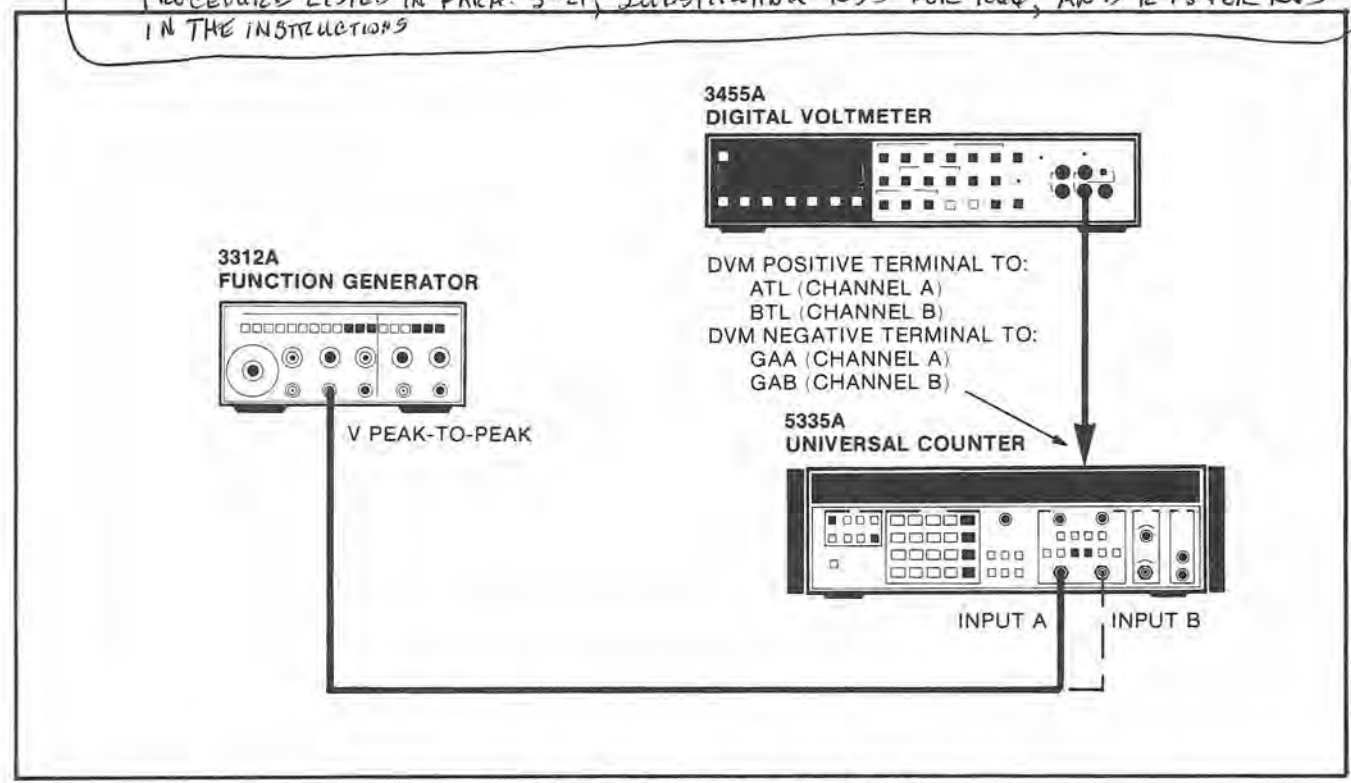

Figure 5-11. Peak Detector Adjustment Setup

SECTION VI REPLACEABLE PARTS

6-1. INTRODUCTION

6-2. This section contains information for ordering parts. *Table 6-1* lists abbreviations used in the parts list and throughout the manual. *Tables 6-2* and *6-3* lists all replaceable parts for the standard 5335A and Option 010 in reference designation order. *Tables 6-4*, *6-5*, and *6-6* list replaceable parts for Options 020, 030, and 040, respectively. *Table 6-7* contains the names and addresses that correspond with the manufacturer's code numbers.

6-3. ABBREVIATIONS

6-4. *Table 6-1* lists abbreviations used in the parts list, schematics, and throughout the manual. In some cases, two forms of the abbreviation are used, one all in capital letters, and one partial or no capitals. This occurs because the abbreviations in the parts list are always all capitals. However, in the schematics and other parts of the manual, other abbreviations forms are used with lower case and upper case letters.

6-5. REPLACEABLE PARTS

6-6. *Tables 6-2* through *6-6* are the lists of replaceable parts, and are organized as follows:

- a. Electrical assemblies and their components in alphanumerical order by reference designation.
- b. Miscellaneous chassis-mounted electrical parts in alphanumerical order by reference designation.
- c. Miscellaneous chassis and mechanical parts.

6-7. The information given for each part consists of the following:

- a. The Hewlett-Packard part number.
- b. The part number check digit (CD).
- c. The total quantity (Qty) used in the assembly.
- d. The description of the part.
- e. A typical manufacturer of the part in a five-digit code.

- f. The manufacturer's number for the part.

6-8. The total quantity of each part used within an assembly is given only once at the first appearance of the part number in the list.

6-9. ORDERING INFORMATION

6-10. To order a part listed in the replaceable parts table, quote the Hewlett-Packard part number, indicate the quantity required, and address the order to the nearest Hewlett-Packard office.

6-11. To order a part that is not listed in the replaceable parts table, include the instrument model number, serial number, the description and function of the part, and the number of parts required. Address the order to the nearest Hewlett-Packard office.

6-12. DIRECT MAIL ORDER SYSTEM

6-13. Within the USA, Hewlett-Packard can supply parts through a direct mail order system. Advantages of using the system are:

- a. Direct ordering and shipment from the HP Parts Center in Mountain View, California.
- b. No maximum or minimum on any mail order (there is a minimum order amount for parts ordered through a local HP office when the orders require billing and invoicing).
- c. Prepaid transportation (there is a small handling charge for each order).
- d. No invoices — to provide these advantages, a check or money order must accompany each order.

6-14. Mail order forms and specific ordering information is available through your local HP office. Addresses and phone numbers are located at the back of this manual.

REFERENCE DESIGNATIONS

| | | | |
|--|---|--|---|
| A = assembly | DL = delay line | K = relay | T = transformer |
| AT = attenuator; isolator; termination | DS = annunciator; signaling device (audible or visual); lamp; LED | L = coil; inductor | TB = terminal board |
| B = fan; motor | E = miscellaneous electrical part | M = metre | TC = thermocouple |
| BT = battery | F = fuse | MP = miscellaneous mechanical part | TP = test point |
| C = capacitor | FL = filter | U = electrical connector (movable portion); plug | U = integrated circuit; microcircuit |
| CP = coupler | H = hardware | Q = transistor; SCR; triode thyristor | V = electron tube |
| CR = diode; diode thyristor; varactor | HY = circulator | R = resistor | VR = voltage regulator; breakdown diode |
| DC = directional coupler | J = electrical connector (stationary portion); jack | RT = thermistor | W = cable; transmission path; wire |
| | | S = switch | X = socket |
| | | | Y = crystal unit-piezo-electric |
| | | | Z = tuned cavity; tuned circuit |

ABBREVIATIONS

| | | | |
|---|--|---|--|
| A = ampere | HD = head | NE = neon | SPST = single-pole, single-throw |
| ac = alternating current | HDW = hardware | NEG = negative | SSB = single sideband |
| ACCESS = accessory | HF = high frequency | nF = nanofarad | SST = stainless steel |
| ADJ = adjustment | HG = mercury | NI PL = nickel plate | STL = steel |
| A/D = analog-to-digital | HI = high | N/O = normally open | SQ = square |
| AF = audio frequency | HP = Hewlett-Packard | NOM = nominal | SWR = standing-wave ratio |
| AFC = automatic frequency control | HPF = high pass filter | NORM = normal | SYNC = synchronize |
| AGC = automatic gain control | HR = hour (used in parts list) | NPN = negative-positive-negative | T = timed (slow-blow fuse) |
| AL = aluminum | HV = high voltage | NPO = negative-positive zero (zero temperature coefficient) | TA = tantalum |
| ALC = automatic level control | Hz = hertz | NRFR = not recommended for field replacement | TC = temperature compensating |
| AM = amplitude modulation | IC = integrated circuit | ns = nanosecond | TD = time delay |
| AMPL = amplifier | ID = inside diameter | NSR = not separately replaceable | TERM = terminal |
| APC = automatic phase control | IF = intermediate frequency | nW = nanowatt | TFT = thin-film transistor |
| ASSY = assembly | IMPG = impregnated | OBD = order by description | TGL = toggle |
| AUX = auxiliary | in = inch | OD = outside diameter | THD = thread |
| AVG = average | INCD = incandescent | OH = oval head | THRU = through |
| AWG = american wire gauge | INCL = include(s) | OP AMPL = operational amplifier | TI = titanium |
| BAL = balance | INP = input | OPT = option | TOL = tolerance |
| BCD = binary coded decimal | INS = insulation | OSC = oscillator | TRIM = trimmer |
| BD = board | INT = internal | OX = oxide | TSTR = transistor |
| BE CU = beryllium copper | kg = kilogram | oz = ounce | TTL = transistor-transistor logic |
| BFO = beat frequency oscillator | kHz = kilohertz | Ω = ohm | TV = television |
| BH = binder head | kΩ = kilohm | P = peak (used in parts list) | TWT = traveling wave tube |
| BKDN = breakdown | kV = kilovolt | PAM = pulse-amplitude modulation | U = micro (10 ⁻⁶) used in parts list |
| BP = bandpass | lb = pound | PC = printed circuit | UF = microfarad (used in parts list) |
| BPF = bandpass filter | LC = inductance-capacitance | PCM = pulse-code modulation; pulse-count modulation | UHFG = ultrahigh frequency |
| BRS = brass | LED = light-emitting diode | PDM = pulse-duration modulation | UNREG = unregulated |
| BWO = backward-wave oscillator | LF = low frequency | pF = picofarad | V = volt |
| CAL = calibrate | LG = long | PH BRZ = phosphor bronze | VA = voltampere |
| ccw = counterclockwise | LH = left hand | PHL = phillips | Vac = volts ac |
| CER = ceramic | LIM = limit | PIN = positive-intrinsic-negative | VAR = variable |
| CHAN = channel | LIN = linear taper (used in parts list) | PIV = peak inverse voltage | VCO = voltage-controlled oscillator |
| cm = centimeter | lin = linear | pk = peak | Vdc = volts dc |
| CMO = coaxial | LK WASH = lockwasher | PL = phase lock | VDCW = volts, dc, working (used in parts list) |
| COEF = coefficient | LO = low; local oscillator | PLO = phase lock oscillator | V(F) = volts, filtered |
| COM = common | LOG = logarithmic taper (used in parts list) | PM = phase modulation | VFO = variable-frequency oscillator |
| COMP = composition | log = logarithm(ic) | PMP = positive-negative-positive | VHF = very-high frequency |
| COMPL = complete | LPF = low pass filter | P/O = part of | Vpk = volts peak |
| CONN = connector | LV = low voltage | POLY = polystyrene | Vp-p = volts peak-to-peak |
| CNN = cadmium plate | m = metre (distance) | PORC = porcelain | Vrms = volts rms |
| CRT = cathode-ray tube | mA = milliampere | POS = positive; position(s) (used in parts list) | VSWR = voltage standing wave ratio |
| CTL = complementary transistor logic | MAX = maximum | POSN = position | VTO = voltage-tuned oscillator |
| CW = continuous wave | MΩ = megohm | POT = potentiometer | VTVM = vacuum-tube voltmeter |
| cw = clockwise | MEG = meg (10 ⁶) (used in parts list) | p-p = peak-to-peak (used in parts list) | V(X) = volts, switched |
| D/A = digital-to-analog | MET FLM = metal film | PP = pulse-position modulation | W = watt |
| dB = decibel | MET OX = metal oxide | PPM = pulse-position modulation | W/ = with |
| dBm = decibel referred to 1 mW | MF = medium frequency; microfarad (used in parts list) | PREAMPL = preamplifier | WIV = working inverse voltage |
| dc = direct current | MFR = manufacturer | PRF = pulse-repetition frequency | WW = wirewound |
| deg = degree (temperature interval or difference) | mg = milligram | PRR = pulse repetition rate | W/O = without |
| ° = degree (plane angle) | MHz = megahertz | ps = picosecond | YIG = yttrium-iron-garnet |
| °C = degree Celsius (centigrade) | mH = millihenry | PT = point | Zo = characteristic impedance |
| °F = degree Fahrenheit | mho = conductance | PTM = pulse-time modulation | |
| °K = degree Kelvin | MIN = minimum | PWM = pulse-width modulation | |
| DEPC = deposited carbon | mip = minute (time) | PWV = peak working voltage | |
| DET = detector | ... = minute (plane angle) | RC = resistance capacitance | |
| diam = diameter | MINAT = miniature | RECT = rectifier | |
| DIA = diameter (used in parts list) | mm = millimeter | REF = reference | |
| DIFF AMPL = differential amplifier | MOD = modulator | REG = regulated | |
| div = division | MOM = momentary | REPL = replaceable | |
| DPDT = double-pole, double-throw | MOS = metal-oxide semiconductor | RF = radio frequency | |
| DR = drive | ms = millisecond | RFI = radio frequency interference | |
| DSB = double sideband | MTG = mounting | RH = round head; right hand | |
| DTL = diode transistor logic | MTR = meter (indicating device) | RLC = resistance-inductance-capacitance | |
| DVM = digital voltmeter | mV = millivolt | RMO = rack mount only | |
| ECL = emitter coupled logic | mV ac = millivolt, ac | rms = root-mean-square | |
| EMF = electromotive force | mVdc = millivolt, dc | RND = round | |
| EDP = electronic data processing | mVpk = millivolt, peak | ROM = read-only memory | |
| ELECT = electrolytic | mVp-p = millivolt, peak-to-peak | R&P = rack and panel | |
| ENCAP = encapsulated | mVrms = millivolt, rms | RWV = reverse working voltage | |
| EXT = external | mW = milliwatt | S = scattering parameter | |
| F = farad | MUX = multiplex | S... = second (time) | |
| FET = field-effect transistor | MY = mylar | S... = second (plane angle) | |
| F/F = flip-flop | μA = microampere | S-B = slow-blow fuse (used in parts list) | |
| FH = flat head | μF = microfarad | SCR = silicon controlled rectifier; screw | |
| FOL H = fillister head | μH = microhenry | SE = selenium | |
| FM = frequency modulation | μmho = micromho | SECT = sections | |
| FP = front panel | μs = microsecond | SEMICON = semiconductor | |
| FREQ = frequency | μV = microvolt | SHF = superhigh frequency | |
| FXD = fixed | μV ac = microvolt, ac | SI = silicon | |
| g = gram | μVdc = microvolt, dc | SIL = silver | |
| GE = germanium | μVpk = microvolt, peak | SL = slide | |
| GHz = gigahertz | μVp-p = microvolt, peak-to-peak | SNR = signal-to-noise ratio | |
| GL = glass | μVrms = microvolt, rms | SPDT = single-pole, double-throw | |
| GND = ground(ed) | μW = microwatt | SPG = spring | |
| H = henry | nA = nanoampere | SR = split ring | |
| h = hour | NC = no connection | | |
| HET = heterodyne | N/C = normally closed | | |
| HEX = hexagonal | | | |

NOTE

All abbreviations in the parts list will be in upper case.

MULTIPLIERS

| Abbreviation | Prefix | Multiple |
|--------------|--------|-------------------|
| T | tera | 10 ¹² |
| G | giga | 10 ⁹ |
| M | mega | 10 ⁶ |
| k | kilo | 10 ³ |
| da | deka | 10 |
| d | deci | 10 ⁻¹ |
| c | centi | 10 ⁻² |
| m | milli | 10 ⁻³ |
| μ | micro | 10 ⁻⁶ |
| n | nano | 10 ⁻⁹ |
| p | pico | 10 ⁻¹² |
| f | femto | 10 ⁻¹⁵ |
| a | atto | 10 ⁻¹⁸ |

Table 6-2. Replaceable Parts

| Reference Designation | HP Part Number | C D | Qty | Description | Mfr Code | Mfr Part Number |
|-----------------------|----------------|--------|-----|--|----------|-------------------|
| A1 | 05335-60001 | 7 | 1 | BOARD ASSEMBLY-POWER SUPPLY(SERIES 2044) | 28480 | 05335-60001 |
| A1C1 | 0180-1746 | 5 | 3 | CAPACITOR-FXD 15UF+-10% 20VDC TA | 56289 | 150D156X9020B2 |
| A1C2 | 0180-2865 | 1 | 1 | CAPACITOR-FXD 100UF+100-10% 15VDC AL | 28480 | 0180-2865 |
| A1C3 | 0180-1701 | 2 | 1 | CAPACITOR-FXD 6.8UF+-20% 6VDC TA | 56289 | 150D685X0006A2 |
| A1C4 | 0180-0230 | 0 | 3 | CAPACITOR-FXD 1UF+-20% 50VDC TA | 56289 | 150D105X0050A2 |
| A1C5 | 0160-2208 | 4 | 2 | CAPACITOR-FXD 330PF +-5% 300VDC MICA | 28480 | 0160-2208 |
| A1C6 | 0180-1746 | 5 | | CAPACITOR-FXD 15UF+-10% 20VDC TA | 56289 | 150D156X9020B2 |
| A1C7 | 0180-0230 | 0 | | CAPACITOR-FXD 1UF+-20% 50VDC TA | 56289 | 150D105X0050A2 |
| A1C8 | 0160-3879 | 7 | 1 | CAPACITOR-FXD .01UF +-20% 100VDC CER | 28480 | 0160-3879 |
| A1C9 | 0160-2208 | 4 | | CAPACITOR-FXD 330PF +-5% 300VDC MICA | 28480 | 0160-2208 |
| A1C10 | 0180-1746 | 5 | | CAPACITOR-FXD 15UF+-10% 20VDC TA | 56289 | 150D156X9020B2 |
| A1C11 | 0180-0230 | 0 | | CAPACITOR-FXD 1UF+-20% 50VDC TA | 56289 | 150D105X0050A2 |
| A1C12 | 0180-2351 | 0 | 2 | CAPACITOR-FXD 2000UF+75-10% 50VDC AL | 28480 | 0180-2351 |
| A1C13 | 0180-2351 | 0 | | CAPACITOR-FXD 2000UF+75-10% 50VDC AL | 28480 | 0180-2351 |
| A1C14 | 0180-2799 | 0 | 1 | CAPACITOR-FXD .017F+75-10% 20VDC AL | 28480 | 0180-2799 |
| A1C15 | 0160-4557 | 0 | 1 | CAPACITOR-FXD .1UF +-20% 50VDC CER | 16299 | CAC04X7R104M050A |
| A1C16 | 0180-0567 | 6 | 1 | CAPACITOR-FXD 8000UF+75-10% 30VDC AL | 00853 | 500802U030AB2B |
| A1CR1 | 1902-0522 | 6 | 2 | DIODE-ZNR 1N5340B 6V 5% PD=5W IR=1UA | 04713 | 1N5340B |
| A1CR2 | 1902-0632 | 9 | 1 | DIODE-ZNR 1N5354B 17V 5% PD=5W TC=+75% | 04713 | 1N5354B |
| A1CR3 | 1902-0522 | 6 | | DIODE-ZNR 1N5340B 6V 5% PD=5W IR=1UA | 04713 | 1N5340B |
| A1CR4 | 1901-0662 | 3 | 1 | DIODE-PWR RECT 100V 6A | 04713 | MR751 |
| A1CR5 | | | | NOT ASSIGNED | | |
| A1CR6 | 1901-0731 | 7 | 1 | DIODE-PWR RECT 400V 1A | 28480 | 1901-0731 |
| A1CR7 | 1901-0050 | 3 | 2 | DIODE-SWITCHING 80V 200MA 2NS DO-35 | 28480 | 1901-0050 |
| A1CR8 | 1906-0096 | 7 | 1 | DIODE-FW BRDG 200V 2A | 04713 | MDA202 |
| A1CR9 | 1901-0673 | 6 | 2 | DIODE-PWR RECT 100V 5A 5US | 03508 | A15A |
| A1CR10 | 1901-0673 | 6 | | DIODE-PWR RECT 100V 5A 5US | 03508 | A15A |
| A1CR11 | 1906-0213 | 0 | 1 | DIODE-CT-RECT 200V 12A | 01295 | TIR101B |
| A1CR12 | 1901-0050 | 3 | | DIODE-SWITCHING 80V 200MA 2NS DO-35 | 28480 | 1901-0050 |
| A1F1 | 2110-0010 | 9 | 1 | FUSE 5A 250V NTD 1.25X.25 UL | 75915 | 312005 |
| A1F2 | 2110-0043 | 8 | 2 | FUSE 1.5A 250V NTD 1.25X.25 UL | 28480 | 2110-0043 |
| A1F3 | 2110-0083 | 6 | 1 | FUSE 2.5A 250V NTD 1.25X.25 UL | 28480 | 2110-0083 |
| A1F4 | 2110-0043 | 8 | | FUSE 1.5A 250V NTD 1.25X.25 UL | 28480 | 2110-0043 |
| A1J1 | 1251-6608 | 0 | 1 | CONNECTOR 16-PIN M POST TYPE | 28480 | 1251-6608 |
| A1J2 | | | | NOT ASSIGNED | | |
| A1J3 | 1251-0600 | 0 | 9 | CONNECTOR-SGL CONT PIN 1.14-MM-BSC-SZ SQ | 28480 | 1251-0600 |
| A1J4 | 1251-0600 | 0 | | CONNECTOR-SGL CONT PIN 1.14-MM-BSC-SZ SQ | 28480 | 1251-0600 |
| A1J5 | 1251-0600 | 0 | | CONNECTOR-SGL CONT PIN 1.14-MM-BSC-SZ SQ | 28480 | 1251-0600 |
| A1J6 | 1251-0600 | 0 | | CONNECTOR-SGL CONT PIN 1.14-MM-BSC-SZ SQ | 28480 | 1251-0600 |
| A1J7 | 1251-0600 | 0 | | CONNECTOR-SGL CONT PIN 1.14-MM-BSC-SZ SQ | 28480 | 1251-0600 |
| A1J8 | 1251-0600 | 0 | | CONNECTOR-SGL CONT PIN 1.14-MM-BSC-SZ SQ | 28480 | 1251-0600 |
| A1J9 | 1251-0600 | 0 | | CONNECTOR-SGL CONT PIN 1.14-MM-BSC-SZ SQ | 28480 | 1251-0600 |
| A1J10 | 1251-0600 | 0 | | CONNECTOR-SGL CONT PIN 1.14-MM-BSC-SZ SQ | 28480 | 1251-0600 |
| A1J11 | 1251-0600 | 0 | | CONNECTOR-SGL CONT PIN 1.14-MM-BSC-SZ SQ | 28480 | 1251-0600 |
| A1K1 | 0490-1172 | 8 | 1 | RELAY 6A 24VDC-COIL 5A 115VAC | 28480 | 0490-1172 |
| A1Q1 | 1853-0454 | 8 | 1 | TRANSISTOR PNP SI DARL TO-220AB PD=2W | 01295 | TIP106 |
| A1Q2 | 1853-0036 | 2 | 1 | TRANSISTOR PNP SI PD=310MW FT=250MHZ | 28480 | 1853-0036 |
| A1Q3 | 1854-0215 | 1 | 1 | TRANSISTOR NPN SI PD=350MW FT=300MHZ | 04713 | 2N3904 |
| A1R1 | 2100-3212 | 8 | 1 | RESISTOR-TRMR 200 10% C TOP-ADJ 1-TRN | 28480 | 2100-3212 |
| A1R2 | 0812-0019 | 4 | 1 | RESISTOR .33 5% 3W PW TC=0+-90 | 28480 | 0812-0019 |
| A1R3 | 0757-0401 | 0 | 1 | RESISTOR 100 1% .125W F TC=0+-100 | 24546 | C4-1/8-T0-101-F |
| A1R4 | 0698-0063 | 4 | 1 | RESISTOR 5.23K 1% .125W F TC=0+-100 | 91637 | CMF-1/8-T1-5231-F |
| A1R5 | 0757-0442 | 9 | 1 | RESISTOR 10K 1% .125W F TC=0+-100 | 24546 | C4-1/8-T0-1002-F |
| A1R6 | 0757-0280 | 3 | 4 | RESISTOR 1K 1% .125W F TC=0+-100 | 24546 | C4-1/8-T0-1001-F |
| A1R7 | 0812-0045 | 6 | 1 | RESISTOR .15 5% 3W PW TC=0+-90 | 28480 | 0812-0045 |
| A1R8 | 0757-0438 | 3 | 1 | RESISTOR 5.11K 1% .125W F TC=0+-100 | 24546 | C4-1/8-T0-5111-F |
| A1R9 | 0698-4002 | 9 | 1 | RESISTOR 5K 1% .125W F TC=0+-100 | 24546 | C4-1/8-T0-5001-F |
| A1R10 | 0757-0280 | 3 | | RESISTOR 1K 1% .125W F TC=0+-100 | 24546 | C4-1/8-T0-1001-F |
| A1R11 | 0698-0084 | 9 | 2 | RESISTOR 2.15K 1% .125W F TC=0+-100 | 24546 | C4-1/8-T0-2151-F |
| A1R12 | 0698-0084 | 9 | | RESISTOR 2.15K 1% .125W F TC=0+-100 | 24546 | C4-1/8-T0-2151-F |
| A1R13 | 0757-0280 | 3 | | RESISTOR 1K 1% .125W F TC=0+-100 | 24546 | C4-1/8-T0-1001-F |
| A1R14 | 0757-0280 | 3 | | RESISTOR 1K 1% .125W F TC=0+-100 | 24546 | C4-1/8-T0-1001-F |
| A1R15 | 2100-3383 | 4 | 1 | RESISTOR-TRMR 50 10% C TOP-ADJ 1-TRN | 28480 | 2100-3383 |
| A1R16 | 0757-0421 | 4 | 1 | RESISTOR 825 1% .125W F TC=0+-100 | 24546 | C4-1/8-T0-825R-F |
| A1TP1 | 1251-4707 | 6 | 2 | CONNECTOR-SGL CONT PIN .031-IN-BSC-SZ | 28480 | 1251-4707 |
| A1TP2 | 1251-4707 | 6 | | CONNECTOR-SGL CONT PIN .031-IN-BSC-SZ | 28480 | 1251-4707 |
| A1U1 | 1826-0316 | 4 | 1 | V REF TO-5 | 27014 | LH0070-1H |
| A1U2 | 1820-0477 | 6 | 2 | IC OP AMP GP 8-DIP-P PKG | 50545 | UPC301AC |
| A1U3 | 1820-0477 | 6 | | IC OP AMP GP 8-DIP-P PKG | 50545 | UPC301AC |
| A1U4 | 1826-0393 | 7 | 1 | IC V RGLTR TO-220 | 27014 | LM317T |
| A1U6 | 1826-0607 | 6 | 1 | IC-REGULATOR 7815A 15V | 28480 | 1826-0607 |

See introduction to this section for ordering information

*Indicates factory selected value

Reproduced with permission,

Courtesy of Agilent Technologies Inc.

Table 6-2. Replaceable Parts (Continued)

| Reference Designation | HP Part Number | C D | Qty | Description | Mfr Code | Mfr Part Number |
|-----------------------|----------------|--------|-----|-------------------------------------|----------|-----------------|
| A1U7 | 1826-0214 | 1 | 1 | IC V RGLTR TO-220 | 04713 | MC7915CT |
| A1XA2P2 | 1251-2160 | 1 | 1 | CONNECTOR-PC EDGE 6-CONT/ROW 2-ROWS | 28480 | 1251-2160 |
| A1XF1 | 2110-0269 | 0 | 8 | FUSEHOLDER-CLIP TYPE.25D-FUSE | 28480 | 2110-0269 |
| A1XF2 | 2110-0269 | 0 | | FUSEHOLDER-CLIP TYPE.25D-FUSE | 28480 | 2110-0269 |
| A1XF3 | 2110-0269 | 0 | | FUSEHOLDER-CLIP TYPE.25D-FUSE | 28480 | 2110-0269 |
| A1XF4 | 2110-0269 | 0 | | FUSEHOLDER-CLIP TYPE.25D-FUSE | 28480 | 2110-0269 |
| A1XK1 | 0490-0468 | 3 | 1 | SOCKET-RLY 16-CONT CRADLE DIP-SLDR | 28480 | 0490-0468 |
| | | | | A1 MISCELLANEOUS PARTS | | |
| A1MP1 | 05335-00005 | 5 | 1 | HEAT SINK FOR A1CR11 | 28480 | 05335-00005 |

See introduction to this section for ordering information

*Indicates factory selected value

Reproduced with permission,
 Courtesy of Agilent Technologies Inc.

Table 6-2. Replaceable Parts (Continued)

| Reference Designation | HP Part Number | C D | Qty | Description | Mfr Code | Mfr Part Number |
|-----------------------|----------------|-----|-----|---------------------------------------|----------|--------------------|
| A2 | 05335-60002 | 8 | 1 | BOARD ASSEMBLY-AMP SUPP(SERIES 2224) | 28480 | 05335-60002 |
| A2C1 | 0160-4557 | 0 | 4 | CAPACITOR-FXD .1UF +-20% 50VDC CER | 16299 | CAC04X7R104M050A |
| A2C2 | 0160-4557 | 0 | | CAPACITOR-FXD .1UF +-20% 50VDC CER | 16299 | CAC04X7R104M050A |
| A2C3 | 0160-4557 | 0 | | CAPACITOR-FXD .1UF +-20% 50VDC CER | 16299 | CAC04X7R104M050A |
| A2C4 | 0160-4557 | 0 | | CAPACITOR-FXD .1UF +-20% 50VDC CER | 16299 | CAC04X7R104M050A |
| A2C5 | 0160-3879 | 7 | 6 | CAPACITOR-FXD .01UF +-20% 100VDC CER | 28480 | 0160-3879 |
| A2C6 | 0160-4554 | 7 | 6 | CAPACITOR-FXD .01UF +-20% 50VDC CER | 28480 | 0160-4554 |
| A2C7 | 0160-0127 | 2 | 2 | CAPACITOR-FXD 1UF +-20% 25VDC CER | 28480 | 0160-0127 |
| A2C8 | 0160-4554 | 7 | | CAPACITOR-FXD .01UF +-20% 50VDC CER | 28480 | 0160-4554 |
| A2C9 | 0160-0127 | 2 | | CAPACITOR-FXD 1UF +-20% 25VDC CER | 28480 | 0160-0127 |
| A2C10 | 0160-3879 | 7 | | CAPACITOR-FXD .01UF +-20% 100VDC CER | 28480 | 0160-3879 |
| A2C11 | 0160-3879 | 7 | | CAPACITOR-FXD .01UF +-20% 100VDC CER | 28480 | 0160-3879 |
| A2C12 | 0160-3879 | 7 | | CAPACITOR-FXD .01UF +-20% 100VDC CER | 28480 | 0160-3879 |
| A2C13 | 0160-3879 | 7 | | CAPACITOR-FXD .01UF +-20% 100VDC CER | 28480 | 0160-3879 |
| A2C14 | 0160-2219 | 7 | 1 | CAPACITOR-FXD 1100PF +-5% 300VDC MICA | 28480 | 0160-2219 |
| A2C15 | 0140-0210 | 2 | 1 | CAPACITOR-FXD 270PF +-5% 300VDC MICA | 72136 | DM15F271J0300WV1CR |
| A2C16 | 0160-4554 | 7 | | CAPACITOR-FXD .01UF +-20% 50VDC CER | 28480 | 0160-4554 |
| A2C17 | 0160-4554 | 7 | | CAPACITOR-FXD .01UF +-20% 50VDC CER | 28480 | 0160-4554 |
| A2C18 | 0160-3879 | 7 | | CAPACITOR-FXD .01UF +-20% 100VDC CER | 28480 | 0160-3879 |
| A2C19 | 0160-4554 | 7 | | CAPACITOR-FXD .01UF +-20% 50VDC CER | 28480 | 0160-4554 |
| A2C20 | 0160-4554 | 7 | | CAPACITOR-FXD .01UF +-20% 50VDC CER | 28480 | 0160-4554 |
| A2CR1 | 1901-0376 | 6 | 2 | DIODE-GEN PRP 35V 50MA DO-35 | 28480 | 1901-0376 |
| A2CR2 | 1901-0376 | 6 | | DIODE-GEN PRP 35V 50MA DO-35 | 28480 | 1901-0376 |
| A2CR3 | 1901-0050 | 3 | 3 | DIODE-SWITCHING 80V 200MA 2NS DO-35 | 28480 | 1901-0050 |
| A2CR4 | 1902-3097 | 6 | 1 | DIODE-ZNR 5.23V 2% DO-35 PDS-4W | 28480 | 1902-3097 |
| A2CR5 | 1901-0050 | 3 | | DIODE-SWITCHING 80V 200MA 2NS DO-35 | 28480 | 1901-0050 |
| A2CR6 | | | | NOT ASSIGNED | | |
| A2CR7 | | | | NOT ASSIGNED | | |
| A2CR8 | 1901-0050 | 3 | | DIODE-SWITCHING 80V 200MA 2NS DO-35 | 28480 | 1901-0050 |
| A2J1 | 1200-0614 | 9 | 2 | SOCKET-RLY 18-CONT DIP-SLDR | 28480 | 1200-0614 |
| A2J2 | 1200-0614 | 9 | | SOCKET-RLY 18-CONT DIP-SLDR | 28480 | 1200-0614 |
| A2J3 | 1250-0835 | 1 | 2 | CONNECTOR-RF SMC M PC 50-OHM | 28480 | 1250-0835 |
| A2J4 | 1250-0835 | 1 | | CONNECTOR-RF SMC M PC 50-OHM | 28480 | 1250-0835 |
| A2L1 | 9100-1788 | 6 | 4 | CHOKE-WIDE BAND ZMAX=680 OHMS 180 MHZ | 02114 | VK200 20/48 |
| A2L2 | 9100-1788 | 6 | | CHOKE-WIDE BAND ZMAX=680 OHMS 180 MHZ | 02114 | VK200 20/48 |
| A2L3 | 9100-1788 | 6 | | CHOKE-WIDE BAND ZMAX=680 OHMS 180 MHZ | 02114 | VK200 20/48 |
| A2L4 | 9100-1788 | 6 | | CHOKE-WIDE BAND ZMAX=680 OHMS 180 MHZ | 02114 | VK200 20/48 |
| A2Q1 | 1854-0246 | 8 | 1 | TRANSISTOR NPN SI PD=350MW FT=250MHZ | 04713 | SPS 233 |
| A2R1 | 0757-0280 | 3 | 7 | RESISTOR 1K 1% .125W F TC=0+-100 | 24546 | C4-1/8-T0-1001-F |
| A2R2 | 0757-0280 | 3 | | RESISTOR 1K 1% .125W F TC=0+-100 | 24546 | C4-1/8-T0-1001-F |
| A2R3 | 0757-0443 | 0 | 4 | RESISTOR 11K 1% .125W F TC=0+-100 | 24546 | C4-1/8-T0-1102-F |
| A2R4 | 0698-6943 | 1 | 4 | RESISTOR 20K .1% .125W F TC=0+-50 | 28480 | 0698-6943 |
| A2R5 | 0698-6943 | 1 | | RESISTOR 20K .1% .125W F TC=0+-50 | 28480 | 0698-6943 |
| A2R6 | 0757-0447 | 4 | 4 | RESISTOR 16.2K 1% .125W F TC=0+-100 | 24546 | C4-1/8-T0-1622-F |
| A2R7 | 0698-6943 | 1 | | RESISTOR 20K .1% .125W F TC=0+-50 | 28480 | 0698-6943 |
| A2R8 | 0757-0443 | 0 | | RESISTOR 11K 1% .125W F TC=0+-100 | 24546 | C4-1/8-T0-1102-F |
| A2R9 | 0757-0443 | 0 | | RESISTOR 11K 1% .125W F TC=0+-100 | 24546 | C4-1/8-T0-1102-F |
| A2R10 | 0757-0442 | 9 | 4 | RESISTOR 10K 1% .125W F TC=0+-100 | 24546 | C4-1/8-T0-1002-F |
| A2R11 | 0757-0447 | 4 | | RESISTOR 16.2K 1% .125W F TC=0+-100 | 24546 | C4-1/8-T0-1622-F |
| A2R12 | 0698-4008 | 5 | 8 | RESISTOR 40K 1% .125W F TC=0+-100 | 24546 | C4-1/8-T0-4002-F |
| A2R13 | 0698-4008 | 5 | | RESISTOR 40K 1% .125W F TC=0+-100 | 24546 | C4-1/8-T0-4002-F |
| A2R14 | 0757-0447 | 4 | | RESISTOR 16.2K 1% .125W F TC=0+-100 | 24546 | C4-1/8-T0-1622-F |
| A2R15 | 0757-0416 | 7 | 1 | RESISTOR 511 1% .125W F TC=0+-100 | 24546 | C4-1/8-T0-511R-F |
| A2R16 | 0698-6943 | 1 | | RESISTOR 20K .1% .125W F TC=0+-50 | 28480 | 0698-6943 |
| A2R17 | 0698-4008 | 5 | | RESISTOR 40K 1% .125W F TC=0+-100 | 24546 | C4-1/8-T0-4002-F |
| A2R18 | 0698-4008 | 5 | | RESISTOR 40K 1% .125W F TC=0+-100 | 24546 | C4-1/8-T0-4002-F |
| A2R19 | 0698-4008 | 5 | | RESISTOR 40K 1% .125W F TC=0+-100 | 24546 | C4-1/8-T0-4002-F |
| A2R20 | 0698-4008 | 5 | | RESISTOR 40K 1% .125W F TC=0+-100 | 24546 | C4-1/8-T0-4002-F |
| A2R21 | 0757-0442 | 9 | | RESISTOR 10K 1% .125W F TC=0+-100 | 24546 | C4-1/8-T0-1002-F |
| A2R22 | 0757-0447 | 4 | | RESISTOR 16.2K 1% .125W F TC=0+-100 | 24546 | C4-1/8-T0-1622-F |
| A2R23 | 0698-6369 | 5 | 2 | RESISTOR 1M .1% .25W F TC=0+-25 | 28480 | 0698-6369 |
| A2R24 | 0757-0280 | 3 | | RESISTOR 1K 1% .125W F TC=0+-100 | 24546 | C4-1/8-T0-1001-F |
| A2R25 | 0698-7203 | 8 | 2 | RESISTOR 42.2 1% .05W F TC=0+-100 | 24546 | C3-1/8-T0-42R2-F |
| A2R26 | 0698-7212 | 9 | 2 | RESISTOR 100 1% .05W F TC=0+-100 | 24546 | C3-1/8-T0-100R-F |
| A2R27 | 0698-7222 | 1 | 4 | RESISTOR 261 1% .05W F TC=0+-100 | 24546 | C3-1/8-T0-261R-F |
| A2R28 | 0698-7226 | 5 | 2 | RESISTOR 393 1% .05W F TC=0+-100 | 24546 | C3-1/8-T0-393R-F |
| A2R29 | 0757-0443 | 0 | | RESISTOR 11K 1% .125W F TC=0+-100 | 24546 | C4-1/8-T0-1102-F |
| A2R30 | 0698-4008 | 5 | | RESISTOR 40K 1% .125W F TC=0+-100 | 24546 | C4-1/8-T0-4002-F |
| A2R31 | 0698-4008 | 5 | | RESISTOR 40K 1% .125W F TC=0+-100 | 24546 | C4-1/8-T0-4002-F |
| A2R32 | 0698-7215 | 2 | 2 | RESISTOR 133 1% .05W F TC=0+-100 | 24546 | C3-1/8-T0-133R-F |
| A2R33 | 0757-0399 | 5 | 3 | RESISTOR 82.5 1% .125W F TC=0+-100 | 24546 | C4-1/8-T0-82R5-F |
| A2R34 | 0757-0442 | 9 | | RESISTOR 10K 1% .125W F TC=0+-100 | 24546 | C4-1/8-T0-1002-F |
| A2R35 | 0698-7203 | 8 | | RESISTOR 42.2 1% .05W F TC=0+-100 | 24546 | C3-1/8-T0-42R2-F |

See introduction to this section for ordering information
*Indicates factory selected value

Reproduced with permission,
Courtesy of Agilent Technologies Inc.

Table 6-2. Replaceable Parts (Continued)

| Reference Designation | HP Part Number | C D | Qty | Description | Mfr Code | Mfr Part Number |
|-----------------------|----------------|-----|-----|--|----------|------------------|
| A2R36 | 0698-7212 | 9 | | RESISTOR 100 1% .05W F TC=0+-100 | 24546 | C3-1/8-T0-100R-F |
| A2R37 | 0698-7222 | 1 | | RESISTOR 261 1% .05W F TC=0+-100 | 24546 | C3-1/8-T0-261R-F |
| A2R38 | 0698-7226 | 5 | | RESISTOR 383 1% .05W F TC=0+-100 | 24546 | C3-1/8-T0-383R-F |
| A2R39 | 0757-0399 | 5 | | RESISTOR 82.5 1% .125W F TC=0+-100 | 24546 | C4-1/8-T0-82R5-F |
| A2R40 | 1010-0364 | 9 | 1 | NETWORK-RES 6-SIP470.0 OHM X 5 | 01121 | 206A471 |
| A2R41 | 0757-0442 | 9 | | RESISTOR 10K 1% .125W F TC=0+-100 | 24546 | C4-1/8-T0-1002-F |
| A2R42 | 0698-3437 | 2 | 2 | RESISTOR 133 1% .125W F TC=0+-100 | 24546 | C4-1/8-T0-133R-F |
| A2R43 | 0757-0399 | 5 | | RESISTOR 82.5 1% .125W F TC=0+-100 | 24546 | C4-1/8-T0-82R5-F |
| A2R44 | 0757-0465 | 6 | 2 | RESISTOR 100K 1% .125W F TC=0+-100 | 24546 | C4-1/8-T0-1003-F |
| A2R45 | 0698-8094 | 7 | 1 | RESISTOR 1.82K 1% .5W F TC=0+-100 | 28480 | 0698-8094 |
| A2R46 | 0698-6369 | 5 | | RESISTOR 1M .1% .25W F TC=0+-25 | 28480 | 0698-6369 |
| A2R47 | 0757-0398 | 4 | 2 | RESISTOR 75 1% .125W F TC=0+-100 | 24546 | C4-1/8-T0-75R0-F |
| A2R48 | 0757-1108 | 6 | 2 | RESISTOR 300 1% .125W F TC=0+-100 | 24546 | C4-1/8-T0-301-F |
| A2R49 | 0757-1108 | 6 | | RESISTOR 300 1% .125W F TC=0+-100 | 24546 | C4-1/8-T0-301-F |
| A2R50 | 0757-0398 | 4 | | RESISTOR 75 1% .125W F TC=0+-100 | 24546 | C4-1/8-T0-75R0-F |
| A2R51 | 0698-7215 | 2 | 1 | RESISTOR 133 1% .05W F TC=0+-100 | 24546 | C3-1/8-T0-133R-F |
| A2R52 | 0698-6612 | 1 | 1 | RESISTOR 2K 1% .125W F TC=0+-50 | 28480 | 0698-6612 |
| A2R53 | 0698-3491 | 8 | 1 | RESISTOR 1K .1% .125W F TC=0+-50 | 28480 | 0698-3491 |
| A2R54 | 0757-0280 | 3 | | RESISTOR 1K 1% .125W F TC=0+-100 | 24546 | C4-1/8-T0-1001-F |
| A2R55 | 0698-7222 | 1 | | RESISTOR 261 1% .05W F TC=0+-100 | 24546 | C3-1/8-T0-261R-F |
| A2R56 | 0698-7222 | 1 | | RESISTOR 261 1% .05W F TC=0+-100 | 24546 | C3-1/8-T0-261R-F |
| A2R57 | 0757-0428 | 1 | 1 | RESISTOR 1.62K 1% .125W F TC=0+-100 | 24546 | C4-1/8-T0-1621-F |
| A2R58 | 0757-0280 | 3 | | RESISTOR 1K 1% .125W F TC=0+-100 | 24546 | C4-1/8-T0-1001-F |
| A2R59 | 0698-3437 | 2 | | RESISTOR 133 1% .125W F TC=0+-100 | 24546 | C4-1/8-T0-133R-F |
| A2R60 | 0757-0465 | 6 | | RESISTOR 100K 1% .125W F TC=0+-100 | 24546 | C4-1/8-T0-1003-F |
| A2R61 | 1810-0280 | 8 | 1 | NETWORK-RES 10-SIP10.0K OHM X 9 | 01121 | 210A103 |
| A2R62 | 0757-0280 | 3 | | RESISTOR 1K 1% .125W F TC=0+-100 | 24546 | C4-1/8-T0-1001-F |
| A2R63 | 0757-0280 | 3 | | RESISTOR 1K 1% .125W F TC=0+-100 | 24546 | C4-1/8-T0-1001-F |
| A2R64 | 0757-0317 | 7 | 1 | RESISTOR 1.33K 1% .125W F TC=0+-100 | 24546 | C4-1/8-T0-1331-F |
| A2R65 | 2100-3383 | 4 | 2 | RESISTOR-TRMR 50 10% C TOP-ADJ 1-TRN | 28480 | 2100-3383 |
| A2R66 | 2100-3383 | 4 | | RESISTOR-TRMR 50 10% C TOP-ADJ 1-TRN | 28480 | 2100-3383 |
| A2U1 | 1826-0315 | 3 | 3 | IC OP AMP GP QUAD 14-DIP-P PKG | 27014 | LH348N |
| A2U2 | 1826-0609 | 8 | 3 | IC MULTIPLEX ANLG 16-DIP-C PKG | 06665 | MUX08FQ |
| A2U3 | 1826-0315 | 3 | | IC OP AMP GP QUAD 14-DIP-P PKG | 27014 | LH348N |
| A2U4 | 1826-0609 | 8 | | IC MULTIPLEX ANLG 16-DIP-C PKG | 06665 | MUX08FQ |
| A2U5 | 1826-0610 | 1 | 1 | IC MULTIPLEX 4-CHAN-ANLG DUAL 16-DIP-C | 06665 | MUX24FQ |
| A2U6 | 1858-0040 | 8 | 1 | TRANSISTOR ARRAY 16-PIN PLSTC DIP | 3L585 | CA3127E |
| A2U7 | 1820-1359 | 5 | 1 | IC MUXR/DATA-SEL ECL 4-T0-1-LINE DUAL | 04713 | MC10174P |
| A2U8 | 1820-1173 | 1 | 1 | IC XLTR ECL TTL-T0-ECL QUAD 2-INP | 04713 | MC10124L |
| A2U9 | 1826-0575 | 7 | 1 | IC CONV V/FREQ 14-DIP-P PKG | 15818 | 9400CJ |
| A2U10 | 1826-0609 | 8 | | IC MULTIPLEX ANLG 16-DIP-C PKG | 06665 | MUX08FQ |
| A2U11 | 1820-0794 | 0 | 1 | IC FF ECL D-M/S | 04713 | MC1679L |
| A2U12 | 1820-1196 | 8 | 2 | IC FF TTL LS D-TYPE POS-EDGE-TRIG COM | 01295 | SN74LS174N |
| A2U13 | 1826-0315 | 3 | | IC OP AMP GP QUAD 14-DIP-P PKG | 27014 | LH348N |
| A2U14 | 1820-1240 | 3 | 1 | IC DCDR TTL S 3-T0-8-LINE 3-INP | 01295 | SN74S138N |
| A2U15 | 1820-1196 | 8 | | IC FF TTL LS D-TYPE POS-EDGE-TRIG COM | 01295 | SN74LS174N |
| A2U16 | 1820-1917 | 1 | 1 | IC BFR TTL LS LINE DRVR OCTL | 01295 | SN74LS240N |
| A2W1 | 8159-0005 | 0 | 2 | JUMPER-INSULATED 22 AWG LEAD | 28480 | 8159-0005 |
| A2W2 | 8159-0005 | 0 | | JUMPER-INSULATED 22 AWG LEAD | 28480 | 8159-0005 |
| A2XAB | 1251-0472 | 4 | 2 | CONNECTOR-PC EDGE 6-CONT/ROW 2-ROWS | 28480 | 1251-0472 |
| A2XAB | 1251-0472 | 4 | | CONNECTOR-PC EDGE 6-CONT/ROW 2-ROWS | 28480 | 1251-0472 |

See introduction to this section for ordering information
*Indicates factory selected value

Reproduced with permission,
Courtesy of Agilent Technologies Inc.

Table 6-2. Replaceable Parts (Continued)

| Reference Designation | HP Part Number | C D | Qty | Description | Mfr Code | Mfr Part Number |
|-----------------------|----------------|-----|-----|---|----------|------------------|
| A3 | 05335-60003 | 9 | 1 | BOARD ASSEMBLY-AMP BUFFER(SERIES 2224) | 28480 | 05335-60003 |
| A3C1 | 0160-3877 | 5 | 4 | CAPACITOR-FXD 100PF +-20% 200VDC CER | 28480 | 0160-3877 |
| A3C2 | 0180-2814 | 0 | 4 | CAPACITOR-FXD 22UF+-20% 10VDC TA | 28480 | 0180-2814 |
| A3C3 | 0180-2821 | 9 | 4 | CAPACITOR-FXD 22UF+-20% 35VDC TA | 28480 | 0180-2821 |
| A3C4 | 0160-4233 | 9 | 4 | CAPACITOR-FXD .47UF +-5% 50VDC MET-POLYIC | 28480 | 0160-4233 |
| A3C5 | 0160-4325 | 0 | 4 | CAPACITOR-FXD .33UF +-5% 50VDC MET-POLYIC | 28480 | 0160-4325 |
| A3C6 | 0180-2814 | 0 | | CAPACITOR-FXD 22UF+-20% 10VDC TA | 28480 | 0180-2814 |
| A3C7 | 0160-4325 | 0 | | CAPACITOR-FXD .33UF +-5% 50VDC MET-POLYIC | 28480 | 0160-4325 |
| A3C8 | 0160-4233 | 9 | | CAPACITOR-FXD .47UF +-5% 50VDC MET-POLYIC | 28480 | 0160-4233 |
| A3C9 | 0160-3879 | 7 | 28 | CAPACITOR-FXD .01UF +-20% 100VDC CER | 28480 | 0160-3879 |
| A3C10 | 0160-3879 | 7 | | CAPACITOR-FXD .01UF +-20% 100VDC CER | 28480 | 0160-3879 |
| A3C11 | 0160-3879 | 7 | | CAPACITOR-FXD .01UF +-20% 100VDC CER | 28480 | 0160-3879 |
| A3C12 | 0160-3879 | 7 | | CAPACITOR-FXD .01UF +-20% 100VDC CER | 28480 | 0160-3879 |
| A3C13 | 0160-3879 | 7 | | CAPACITOR-FXD .01UF +-20% 100VDC CER | 28480 | 0160-3879 |
| A3C14 | 0160-3879 | 7 | | CAPACITOR-FXD .01UF +-20% 100VDC CER | 28480 | 0160-3879 |
| A3C15 | 0160-3877 | 5 | | CAPACITOR-FXD 100PF +-20% 200VDC CER | 28480 | 0160-3877 |
| A3C16 | 0160-3879 | 7 | | CAPACITOR-FXD .01UF +-20% 100VDC CER | 28480 | 0160-3879 |
| A3C17 | 0160-3879 | 7 | | CAPACITOR-FXD .01UF +-20% 100VDC CER | 28480 | 0160-3879 |
| A3C18 | 0160-3879 | 7 | | CAPACITOR-FXD .01UF +-20% 100VDC CER | 28480 | 0160-3879 |
| A3C19 | 0160-3879 | 7 | | CAPACITOR-FXD .01UF +-20% 100VDC CER | 28480 | 0160-3879 |
| A3C20 | 0160-3879 | 7 | | CAPACITOR-FXD .01UF +-20% 100VDC CER | 28480 | 0160-3879 |
| A3C21 | 0160-4424 | 0 | 2 | CAPACITOR-FXD .047UF +-20% 500VDC CER | 51642 | 400-500-X7R-473M |
| A3C22 | 0160-4705 | 0 | 2 | CAPACITOR-FXD 2.2PF +-5% 500VDC CER | 28480 | 0160-4705 |
| A3C23* | 0160-3875 | 3 | | CAPACITOR-FXD 22PF +-5% 200VDC CER 0+-30 | 28480 | 0160-3875 |
| A3C24 | 0160-4703 | 8 | 2 | CAPACITOR-FXD 68PF +-5% 500VDC CER 0+-30 | 28480 | 0160-4703 |
| A3C25 | 0160-3879 | 7 | | CAPACITOR-FXD .01UF +-20% 100VDC CER | 28480 | 0160-3879 |
| A3C26 | 0160-3879 | 7 | | CAPACITOR-FXD .01UF +-20% 100VDC CER | 28480 | 0160-3879 |
| A3C27* | 0160-4040 | 6 | 2 | CAPACITOR-FXD 1000PF +-5% 100VDC CER | 28480 | 0160-4040 |
| A3C28 | 0180-2821 | 9 | | CAPACITOR-FXD 22UF+-20% 35VDC TA | 28480 | 0180-2821 |
| A3C29 | 0160-3879 | 7 | | CAPACITOR-FXD .01UF +-20% 100VDC CER | 28480 | 0160-3879 |
| A3C30 | 0180-2821 | 9 | | CAPACITOR-FXD 22UF+-20% 35VDC TA | 28480 | 0180-2821 |
| A3C31 | 0160-3879 | 7 | | CAPACITOR-FXD .01UF +-20% 100VDC CER | 28480 | 0160-3879 |
| A3C32 | 0160-3879 | 7 | | CAPACITOR-FXD .01UF +-20% 100VDC CER | 28480 | 0160-3879 |
| A3C33 | 0160-3879 | 7 | | CAPACITOR-FXD .01UF +-20% 100VDC CER | 28480 | 0160-3879 |
| A3C34 | 0160-4703 | 8 | | CAPACITOR-FXD 68PF +-5% 500VDC CER 0+-30 | 28480 | 0160-4703 |
| A3C35 | 0160-4040 | 6 | | CAPACITOR-FXD 1000PF +-5% 100VDC CER | 28480 | 0160-4040 |
| A3C36 | 0160-3879 | 7 | | CAPACITOR-FXD .01UF +-20% 100VDC CER | 28480 | 0160-3879 |
| A3C37* | 0160-3875 | 3 | 2 | CAPACITOR-FXD 22PF +-5% 200VDC CER 0+-30 | 28480 | 0160-3875 |
| A3C38 | 0160-4705 | 0 | | CAPACITOR-FXD 2.2PF +-5% 500VDC CER | 28480 | 0160-4705 |
| A3C39 | 0160-4424 | 0 | | CAPACITOR-FXD .047UF +-20% 500VDC CER | 51642 | 400-500-X7R-473M |
| A3C40 | 0180-2814 | 0 | | CAPACITOR-FXD 22UF+-20% 10VDC TA | 28480 | 0180-2814 |
| A3C41 | 0160-3879 | 7 | | CAPACITOR-FXD .01UF +-20% 100VDC CER | 28480 | 0160-3879 |
| A3C42 | 0160-3879 | 7 | | CAPACITOR-FXD .01UF +-20% 100VDC CER | 28480 | 0160-3879 |
| A3C43 | 0160-3879 | 7 | | CAPACITOR-FXD .01UF +-20% 100VDC CER | 28480 | 0160-3879 |
| A3C44 | 0160-3879 | 7 | | CAPACITOR-FXD .01UF +-20% 100VDC CER | 28480 | 0160-3879 |
| A3C45 | 0160-3879 | 7 | | CAPACITOR-FXD .01UF +-20% 100VDC CER | 28480 | 0160-3879 |
| A3C46 | 0160-3879 | 7 | | CAPACITOR-FXD .01UF +-20% 100VDC CER | 28480 | 0160-3879 |
| A3C47 | 0160-3879 | 7 | | CAPACITOR-FXD .01UF +-20% 100VDC CER | 28480 | 0160-3879 |
| A3C48 | 0160-3879 | 7 | | CAPACITOR-FXD .01UF +-20% 100VDC CER | 28480 | 0160-3879 |
| A3C49 | 0160-3879 | 7 | | CAPACITOR-FXD .01UF +-20% 100VDC CER | 28480 | 0160-3879 |
| A3C50 | 0160-3879 | 7 | | CAPACITOR-FXD .01UF +-20% 100VDC CER | 28480 | 0160-3879 |
| A3C51 | 0160-4325 | 0 | | CAPACITOR-FXD .33UF +-5% 50VDC MET-POLYIC | 28480 | 0160-4325 |
| A3C52 | 0160-4233 | 9 | | CAPACITOR-FXD .47UF +-5% 50VDC MET-POLYIC | 28480 | 0160-4233 |
| A3C53 | 0160-4233 | 9 | | CAPACITOR-FXD .47UF +-5% 50VDC MET-POLYIC | 28480 | 0160-4233 |
| A3C54 | 0180-2821 | 9 | | CAPACITOR-FXD 22UF+-20% 35VDC TA | 28480 | 0180-2821 |
| A3C55 | 0160-3877 | 5 | | CAPACITOR-FXD 100PF +-20% 200VDC CER | 28480 | 0160-3877 |
| A3C56 | 0180-2814 | 0 | | CAPACITOR-FXD 22UF+-20% 10VDC TA | 28480 | 0180-2814 |
| A3C57 | 0160-4325 | 0 | | CAPACITOR-FXD .33UF +-5% 50VDC MET-POLYIC | 28480 | 0160-4325 |
| A3C58 | 0160-3877 | 5 | | CAPACITOR-FXD 100PF +-20% 200VDC CER | 28480 | 0160-3877 |
| A3C59 | | | | NOT ASSIGNED | | |
| A3C60* | 0160-3874 | 2 | 1 | CAPACITOR-FXD 10PF +-1.5PF 200VDC CER | 28480 | 0160-3874 |
| A3CR1,CR4,CR5† | 05335-80003 | 1 | 6 | DIODES-MATCHED SET OF FOUR | 28480 | 05335-80003 |
| A3CR2,CR6,CR7† | 05335-80003 | 1 | | DIODES-MATCHED SET OF FOUR | 28480 | 05335-80003 |
| A3CR3 | 1901-1080 | 1 | 2 | DIODE SCHOTTKY | 28480 | 1901-1080 |
| A3CR8-CR11† | 05335-80003 | 1 | | DIODES-MATCHED SET OF FOUR | 28480 | 05335-80003 |

†MATCHED DIODES AVAILABLE ONLY IN SETS OF FOUR.

See introduction to this section for ordering information
*Indicates factory selected valueReproduced with permission,
Courtesy of Agilent Technologies Inc.

Table 6-2. Replaceable Parts (Continued)

| Reference Designation | HP Part Number | C D | Qty | Description | Mfr Code | Mfr Part Number |
|-----------------------|----------------|-----|-----|---|----------|------------------|
| A3CR11 | 05335-80003 | 1 | | DIODES-MATCHED SET | 28480 | 05335-80003 |
| A3CR12 | 1902-0041 | 4 | 2 | DIODE-ZNR 5.11V 5% DO-35 PD=.4W | 28480 | 1902-0041 |
| A3CR13 | 1902-0057 | 2 | 2 | DIODE-ZNR 6.49V 5% DO-35 PD=.4W | 28480 | 1902-0057 |
| A3CR14 | 1901-0050 | 3 | 1 | DIODE-SWITCHING 80V 200MA 2NS DO-35 | 28480 | 1901-0050 |
| A3CR15 | 1902-3136 | 4 | 2 | DIODE-ZNR 8.06V 5% DO-35 PD=.4W | 28480 | 1902-3136 |
| A3CR16 | 1902-3136 | 4 | | DIODE-ZNR 8.06V 5% DO-35 PD=.4W | 28480 | 1902-3136 |
| A3CR17 | 1901-1080 | 1 | | DIODE-SCHOTTKY 1N5817 20V 1A | 28480 | 1901-1080 |
| A3CR18 | 1902-0057 | 2 | | DIODE-ZNR 6.49V 5% DO-35 PD=.4W | 28480 | 1902-0057 |
| A3CR19 | 1902-0041 | 4 | | DIODE-ZNR 5.11V 5% DO-35 PD=.4W | 28480 | 1902-0041 |
| A3CR20-CR23† | 05335-80003 | 1 | | DIODES-MATCHED SET OF FOUR | 28480 | 05335-80003 |
| A3CR24,CR25,CR28† | 05335-80003 | 1 | | DIODES-MATCHED SET OF FOUR | 28480 | 05335-80003 |
| A3CR26,CR27,CR29† | 05335-80003 | 1 | | DIODES-MATCHED SET OF FOUR | 28480 | 05335-80003 |
| A3DS1 | 1990-0487 | 7 | 2 | LED-LAMP LUM-INT=1MCD IF=20MA-MAX YEL | 28480 | 5082-4584 |
| A3DS2 | 1990-0487 | 7 | | LED-LAMP LUM-INT=1MCD IF=20MA-MAX YEL | 28480 | 5082-4584 |
| A3J1 | 1250-0835 | 1 | 2 | CONNECTOR-RF SMC M PC 50-OHM | 28480 | 1250-0835 |
| A3J2 | 1200-0614 | 9 | 2 | SOCKET-RLY 18-CONT DIP-SLDR | 28480 | 1200-0614 |
| A3J3 | 1250-1671 | 5 | 2 | CONNECTOR-RF BNC FEM SCL-HOLE-RR 50-OHM | 28480 | 1250-1671 |
| A3J4 | 1250-1671 | 5 | | CONNECTOR-RF BNC FEM SCL-HOLE-RR 50-OHM | 28480 | 1250-1671 |
| A3J5 | 1200-0614 | 9 | | SOCKET-RLY 18-CONT DIP-SLDR | 28480 | 1200-0614 |
| A3J6 | 1250-0835 | 1 | | CONNECTOR-RF SMC M PC 50-OHM | 28480 | 1250-0835 |
| A3K1 | 0490-0508 | 2 | 1 | RELAY 2C 12VDC-COIL .5A 28VDC DPDT | 28480 | 0490-0508 |
| A3L1 | 05335-80001 | 9 | 2 | INDUCTOR | 28480 | 05335-80001 |
| A3L2 | 05335-80001 | 9 | | INDUCTOR | 28480 | 05335-80001 |
| A3Q1 | 1854-0686 | 0 | 4 | TRANSISTOR NPN SI TO-72 PD=200MW FT=4GHZ | 28480 | 1854-0686 |
| A3Q2 | 1854-0636 | 0 | 4 | TRANSISTOR NPN SI TO-92 PD=350MW | 28480 | 1854-0636 |
| A3Q3 | 1854-0636 | 0 | | TRANSISTOR NPN SI TO-92 PD=350MW | 28480 | 1854-0636 |
| A3Q4 | 1855-0300 | 7 | 2 | TRANSISTOR J-FET N-CHAN D-MODE TO-106 | 28480 | 1855-0300 |
| A3Q4 ALTERNATE | 1855-0212 | 0 | 2 | TRANSISTOR J-FET N-CHAN SI (ALTERNATE PART) | 28480 | 1855-0212 |
| A3Q5 | 1855-0300 | 7 | | TRANSISTOR J-FET N-CHAN D-MODE TO-106 | 28480 | 1855-0300 |
| A3Q5 ALTERNATE | 1855-0212 | 0 | | TRANSISTOR J-FET N-CHAN SI (ALTERNATE PART) | 28480 | 1855-0212 |
| A3Q6 | 1854-0636 | 0 | | TRANSISTOR NPN SJ TO-92 PD=350MW | 28480 | 1854-0636 |
| A3Q7 | 1854-0636 | 0 | | TRANSISTOR NPN SI TO-92 PD=350MW | 28480 | 1854-0636 |
| A3Q8 | 1854-0686 | 0 | | TRANSISTOR NPN SI TO-72 PD=200MW FT=4GHZ | 28480 | 1854-0686 |
| A3Q9 | 1854-0686 | 0 | | TRANSISTOR NPN SI TO-72 PD=200MW FT=4GHZ | 28480 | 1854-0686 |
| A3Q10 | 1854-0686 | 0 | | TRANSISTOR NPN SI TO-72 PD=200MW FT=4GHZ | 28480 | 1854-0686 |
| A3R1 | 0699-0071 | 6 | 8 | RESISTOR 4.64M 1% .125W F TC=0+-100 | 28480 | 0699-0071 |
| A3R2 | 0699-0071 | 6 | | RESISTOR 4.64M 1% .125W F TC=0+-100 | 28480 | 0699-0071 |
| A3R3 | 0698-7267 | 4 | 8 | RESISTOR 19.6K 1% .05W F TC=0+-100 | 24546 | C3-1/8-T0-1962-F |
| A3R4 | 0698-7267 | 4 | | RESISTOR 19.6K 1% .05W F TC=0+-100 | 24546 | C3-1/8-T0-1962-F |
| A3R5 | 0698-7227 | 6 | 6 | RESISTOR 422 1% .05W F TC=0+-100 | 24546 | C3-1/8-T0-422R-F |
| A3R6 | 0698-7212 | 9 | 6 | RESISTOR 100 1% .05W F TC=0+-100 | 24546 | C3-1/8-T0-100R-F |
| A3R7 | | | | NOT ASSIGNED | | |
| A3R8 | | | | NOT ASSIGNED | | |
| A3R9 | 0698-7212 | 9 | | RESISTOR 100 1% .05W F TC=0+-100 | 24546 | C3-1/8-T0-100R-F |
| A3R10 | 0699-0071 | 6 | | RESISTOR 4.64M 1% .125W F TC=0+-100 | 28480 | 0699-0071 |
| A3R11 | 0699-0071 | 6 | | RESISTOR 4.64M 1% .125W F TC=0+-100 | 28480 | 0699-0071 |
| A3R12 | 0698-7267 | 4 | | RESISTOR 19.6K 1% .05W F TC=0+-100 | 24546 | C3-1/8-T0-1962-F |
| A3R13 | 0698-7267 | 4 | | RESISTOR 19.6K 1% .05W F TC=0+-100 | 24546 | C3-1/8-T0-1962-F |
| A3R14 | 0698-7218 | 5 | 2 | RESISTOR 178 1% .05W F TC=0+-100 | 24546 | C3-1/8-T0-178R-F |
| A3R15 | 0698-7249 | 2 | 4 | RESISTOR 3.48K 1% .05W F TC=0+-100 | 24546 | C3-1/8-T0-3481-F |
| A3R16 | 0698-0087 | 2 | 2 | RESISTOR 316 1% .25W F TC=0+-100 | 24546 | C5-1/4-T0-3160-F |
| A3R17 | 0698-7205 | 0 | 8 | RESISTOR 51.1 1% .05W F TC=0+-100 | 24546 | C3-1/8-T0-51R1-F |
| A3R18 | 0698-7249 | 2 | | RESISTOR 3.48K 1% .05W F TC=0+-100 | 24546 | C3-1/8-T0-3481-F |
| A3R19 | 0698-6433 | 4 | 4 | RESISTOR 100 1% .25W F TC=0+-100 | 28480 | 0698-6433 |
| A3R20 | 0698-6433 | 4 | | RESISTOR 100 1% .25W F TC=0+-100 | 28480 | 0698-6433 |
| A3R21 | 0698-7212 | 9 | | RESISTOR 100 1% .05W F TC=0+-100 | 24546 | C3-1/8-T0-100R-F |
| A3R22 | 2100-3802 | 2 | 2 | RESISTOR-VAR W/SW 10K 20% LIN SPST-ND | 28480 | 2100-3802 |
| A3R23 | 0698-7188 | 8 | 2 | RESISTOR 10 1% .05W F TC=0+-100 | 24546 | C3-1/8-T0-10R-F |
| A3R24 | 0698-7198 | 0 | 6 | RESISTOR 26.1 1% .05W F TC=0+-100 | 24546 | C3-1/8-T0-26R1-F |
| A3R25 | 0698-7198 | 0 | | RESISTOR 26.1 1% .05W F TC=0+-100 | 24546 | C3-1/8-T0-26R1-F |
| A3R26 | 0698-7222 | 1 | 2 | RESISTOR 261 1% .05W F TC=0+-100 | 24546 | C3-1/8-T0-261R-F |
| A3R27 | 0699-0073 | 8 | 2 | RESISTOR 10M 1% .125W F TC=0+-150 | 28480 | 0699-0073 |
| A3R28 | 0698-7205 | 0 | | RESISTOR 51.1 1% .05W F TC=0+-100 | 24546 | C3-1/8-T0-51R1-F |
| A3R29* | 0698-7247 | 0 | 2 | RESISTOR 2.87K 1% .05W F TC=0+-100 | 24546 | C3-1/8-T0-2871-F |
| A3R30 | 0698-3922 | 0 | 4 | RESISTOR 487K 1% .125W F TC=0+-50 | 28480 | 0698-3922 |

†MATCHED DIODES AVAILABLE ONLY IN SETS OF FOUR.

See introduction to this section for ordering information

*Indicates factory selected value

Reproduced with permission,
Courtesy of Agilent Technologies Inc.

Table 6-2. Replaceable Parts (Continued)

| Reference Designation | HP Part Number | C D | Qty | Description | Mfr Code | Mfr Part Number |
|-----------------------|----------------|-----|-----|---------------------------------------|----------|--------------------|
| A3R31 | 0698-7227 | 6 | | RESISTOR 422 1% .05W F TC=0+-100 | 24546 | C3-1/8-T0-422R-F |
| A3R32 | 0698-6400 | 5 | 2 | RESISTOR 900K 1% .25W F TC=0+-100 | 19701 | MFS2C1/4-T0-9003-F |
| A3R33 | 0757-0416 | 7 | 2 | RESISTOR 511 1% .125W F TC=0+-100 | 24546 | C4-1/8-T0-511R-F |
| A3R34 | 0698-7205 | 0 | | RESISTOR 51.1 1% .05W F TC=0+-100 | 24546 | C3-1/8-T0-51R1-F |
| A3R35 | 0698-7216 | 3 | 2 | RESISTOR 147 1% .05W F TC=0+-100 | 24546 | C3-1/8-T0-147R-F |
| A3R36 | 0698-7252 | 7 | 2 | RESISTOR 4.64K 1% .05W F TC=0+-100 | 24546 | C3-1/8-T0-4641-F |
| A3R37 | 2100-1738 | 9 | 2 | RESISTOR-TRMR 10K 10% C TOP-ADJ 1-TRN | 73138 | 82PR10K |
| A3R38 | 0698-7227 | 6 | | RESISTOR 422 1% .05W F TC=0+-100 | 24546 | C3-1/8-T0-422R-F |
| A3R39 | 0698-7245 | 8 | 2 | RESISTOR 2.37K 1% .05W F TC=0+-100 | 24546 | C3-1/8-T0-2371-F |
| A3R40 | 0698-7238 | 9 | 4 | RESISTOR 1.21K 1% .05W F TC=0+-100 | 24546 | C3-1/8-T0-1211-F |
| A3R41 | 0698-7198 | 0 | | RESISTOR 26.1 1% .05W F TC=0+-100 | 24546 | C3-1/8-T0-26R1-F |
| A3R42 | 0698-6430 | 1 | 2 | RESISTOR 111K .5% .125W F TC=0+-100 | 28480 | 0698-6430 |
| A3R43 | 0698-3905 | 9 | 4 | RESISTOR 513K .1% .125W F TC=0+-50 | 28480 | 0698-3905 |
| A3R44 | 0698-7241 | 4 | 2 | RESISTOR 1.62K 1% .05W F TC=0+-100 | 24546 | C3-1/8-T0-1621-F |
| A3R45 | 0698-3905 | 9 | | RESISTOR 513K .1% .125W F TC=0+-50 | 28480 | 0698-3905 |
| A3R46 | 0698-3922 | 0 | | RESISTOR 487K .1% .125W F TC=0+-50 | 28480 | 0698-3922 |
| A3R47 | 2100-2497 | 9 | 2 | RESISTOR-TRMR 2K 10% C TOP-ADJ 1-TRN | 73138 | 82PR2K |
| A3R48 | 0698-7238 | 9 | | RESISTOR 1.21K 1% .05W F TC=0+-100 | 24546 | C3-1/8-T0-1211-F |
| A3R49 | 0698-7245 | 8 | | RESISTOR 2.37K 1% .05W F TC=0+-100 | 24546 | C3-1/8-T0-2371-F |
| A3R50 | 0698-3905 | 9 | | RESISTOR 513K .1% .125W F TC=0+-50 | 28480 | 0698-3905 |
| A3R51 | 0698-6430 | 1 | | RESISTOR 111K .5% .125W F TC=0+-100 | 28480 | 0698-6430 |
| A3R52 | 0698-7238 | 9 | | RESISTOR 1.21K 1% .05W F TC=0+-100 | 24546 | C3-1/8-T0-1211-F |
| A3R53 | 0698-7198 | 0 | | RESISTOR 26.1 1% .05W F TC=0+-100 | 24546 | C3-1/8-T0-26R1-F |
| A3R54 | 0698-7227 | 6 | | RESISTOR 422 1% .05W F TC=0+-100 | 24546 | C3-1/8-T0-422R-F |
| A3R55 | 0698-7216 | 3 | | RESISTOR 147 1% .05W F TC=0+-100 | 24546 | C3-1/8-T0-147R-F |
| A3R56 | 0698-3905 | 9 | | RESISTOR 513K .1% .125W F TC=0+-50 | 28480 | 0698-3905 |
| A3R57 | 0698-7238 | 9 | | RESISTOR 1.21K 1% .05W F TC=0+-100 | 24546 | C3-1/8-T0-1211-F |
| A3R58 | 0757-0416 | 7 | | RESISTOR 511 1% .125W F TC=0+-100 | 24546 | C4-1/8-T0-511R-F |
| A3R59 | 0698-7222 | 1 | | RESISTOR 261 1% .05W F TC=0+-100 | 24546 | C3-1/8-T0-261R-F |
| A3R60 | 0699-0073 | 8 | | RESISTOR 10M 1% .125W F TC=0+-150 | 28480 | 0699-0073 |
| A3R61 | 0698-6400 | 5 | | RESISTOR 900K 1% .25W F TC=0+-100 | 19701 | MFS2C1/4-T0-9003-F |
| A3R62 | 0698-3922 | 0 | | RESISTOR 487K .1% .125W F TC=0+-50 | 28480 | 0698-3922 |
| A3R63 | 0698-3922 | 0 | | RESISTOR 487K .1% .125W F TC=0+-50 | 28480 | 0698-3922 |
| A3R64 | 0698-7227 | 6 | | RESISTOR 422 1% .05W F TC=0+-100 | 24546 | C3-1/8-T0-422R-F |
| A3R65 | 0698-7212 | 9 | | RESISTOR 100 1% .05W F TC=0+-100 | 24546 | C3-1/8-T0-100R-F |
| A3R66 | 2100-3802 | 2 | | RESISTOR-VAR W/SW 10K 20% LIN SPST-NO | 28480 | 2100-3802 |
| A3R67 | 0698-7188 | 8 | | RESISTOR 10 1% .05W F TC=0+-100 | 24546 | C3-1/8-T0-10R-F |
| A3R68 | 0698-7218 | 5 | | RESISTOR 178 1% .05W F TC=0+-100 | 24546 | C3-1/8-T0-178R-F |
| A3R69 | 0698-6433 | 4 | | RESISTOR 100 1% .25W F TC=0+-100 | 28480 | 0698-6433 |
| A3R70 | 0698-6433 | 4 | | RESISTOR 100 1% .25W F TC=0+-100 | 28480 | 0698-6433 |
| A3R71 | 0698-7205 | 0 | | RESISTOR 51.1 1% .05W F TC=0+-100 | 24546 | C3-1/8-T0-51R1-F |
| A3R72 | 0698-7227 | 6 | | RESISTOR 422 1% .05W F TC=0+-100 | 24546 | C3-1/8-T0-422R-F |
| A3R73 | 0698-7249 | 2 | | RESISTOR 3.48K 1% .05W F TC=0+-100 | 24546 | C3-1/8-T0-3481-F |
| A3R74 | 0698-0087 | 2 | | RESISTOR 316 1% .25W F TC=0+-100 | 24546 | C5-1/4-T0-3160-F |
| A3R75 | 0698-7205 | 0 | | RESISTOR 51.1 1% .05W F TC=0+-100 | 24546 | C3-1/8-T0-51R1-F |
| A3R76 | 0698-7249 | 2 | | RESISTOR 3.48K 1% .05W F TC=0+-100 | 24546 | C3-1/8-T0-3481-F |
| A3R77 | 0698-7198 | 0 | | RESISTOR 26.1 1% .05W F TC=0+-100 | 24546 | C3-1/8-T0-26R1-F |
| A3R78 | 0698-7198 | 0 | | RESISTOR 26.1 1% .05W F TC=0+-100 | 24546 | C3-1/8-T0-26R1-F |
| A3R79 | 0698-7212 | 9 | | RESISTOR 100 1% .05W F TC=0+-100 | 24546 | C3-1/8-T0-100R-F |
| A3R80 | | | | NOT ASSIGNED | | |
| A3R81 | | | | NOT ASSIGNED | | |
| A3R82 | 0698-7212 | 9 | | RESISTOR 100 1% .05W F TC=0+-100 | 24546 | C3-1/8-T0-100R-F |
| A3R83* | 0698-7247 | 0 | | RESISTOR 2.87K 1% .05W F TC=0+-100 | 24546 | C3-1/8-T0-2871-F |
| A3R84 | 0698-7267 | 4 | | RESISTOR 19.6K 1% .05W F TC=0+-100 | 24546 | C3-1/8-T0-1962-F |
| A3R85 | 0698-7267 | 4 | | RESISTOR 19.6K 1% .05W F TC=0+-100 | 24546 | C3-1/8-T0-1962-F |
| A3R86 | 0698-7205 | 0 | | RESISTOR 51.1 1% .05W F TC=0+-100 | 24546 | C3-1/8-T0-51R1-F |
| A3R87 | 0698-7252 | 7 | | RESISTOR 4.64K 1% .05W F TC=0+-100 | 24546 | C3-1/8-T0-4641-F |
| A3R88 | 2100-1738 | 9 | | RESISTOR-TRMR 10K 10% C TOP-ADJ 1-TRN | 73138 | 82PR10K |
| A3R89 | 0699-0071 | 6 | | RESISTOR 4.64M 1% .125W F TC=0+-100 | 28480 | 0699-0071 |
| A3R90 | 0699-0071 | 6 | | RESISTOR 4.64M 1% .125W F TC=0+-100 | 28480 | 0699-0071 |
| A3R91 | 0699-0071 | 6 | | RESISTOR 4.64M 1% .125W F TC=0+-100 | 28480 | 0699-0071 |
| A3R92 | 0699-0071 | 6 | | RESISTOR 4.64M 1% .125W F TC=0+-100 | 28480 | 0699-0071 |
| A3R93 | 0698-7241 | 4 | | RESISTOR 1.62K 1% .05W F TC=0+-100 | 24546 | C3-1/8-T0-1621-F |
| A3R94 | 0698-7267 | 4 | | RESISTOR 19.6K 1% .05W F TC=0+-100 | 24546 | C3-1/8-T0-1962-F |
| A3R95 | 0698-7267 | 4 | | RESISTOR 19.6K 1% .05W F TC=0+-100 | 24546 | C3-1/8-T0-1962-F |
| A3R96 | 2100-2497 | 9 | | RESISTOR-TRMR 2K 10% C TOP-ADJ 1-TRN | 73138 | 82PR2K |
| A3R97 | 0698-7284 | 5 | 2 | RESISTOR 100K 1% .05W F TC=0+-100 | 24546 | C3-1/8-T0-1003-F |
| A3R98 | 0698-7284 | 5 | | RESISTOR 100K 1% .05W F TC=0+-100 | 24546 | C3-1/8-T0-1003-F |
| A3R99 | 2100-0644 | 4 | 4 | RESISTOR-TRMR 2M 20% C TOP-ADJ 1-TRN | 28480 | 2100-0644 |
| A3R100 | 2100-0644 | 4 | | RESISTOR-TRMR 2M 20% C TOP-ADJ 1-TRN | 28480 | 2100-0644 |
| A3R101 | 2100-0644 | 4 | | RESISTOR-TRMR 2M 20% C TOP-ADJ 1-TRN | 28480 | 2100-0644 |
| A3R102 | 2100-0644 | 4 | | RESISTOR-TRMR 2M 20% C TOP-ADJ 1-TRN | 28480 | 2100-0644 |
| A3R103 | 0698-7209 | 4 | 2 | RESISTOR 75 1% .05W F TC=0+-100 | 24546 | C3-1/8-T0-75R0-F |
| A3R104 | 0698-7205 | 0 | | RESISTOR 51.1 1% .05W F TC=0+-100 | 24546 | C3-1/8-T0-51R1-F |
| A3R105 | 0698-7209 | 4 | | RESISTOR 75 1% .05W F TC=0+-100 | 24546 | C3-1/8-T0-75R0-F |
| A3R106 | 0698-7205 | 0 | | RESISTOR 51.1 1% .05W F TC=0+-100 | 24546 | C3-1/8-T0-51R1-F |

See introduction to this section for ordering information
 *Indicates factory selected value

Reproduced with permission,
 Courtesy of Agilent Technologies Inc.

Table 6-2. Replaceable Parts (Continued)

| Reference Designation | HP Part Number | C D | Qty | Description | Mfr Code | Mfr Part Number |
|-----------------------|----------------|-----|-----|---|----------|----------------------|
| A3S1 | | | | NSR, PART OF R22 | | |
| A3S2 | 3101-2498 | 3 | 10 | SWITCH-PB DPDT ALTNG .25A 115VAC | 28480 | 3101-2498 |
| A3S3 | 3101-2498 | 3 | | SWITCH-PB DPDT ALTNG .25A 115VAC | 28480 | 3101-2498 |
| A3S4 | 3101-2498 | 3 | | SWITCH-PB DPDT ALTNG .25A 115VAC | 28480 | 3101-2498 |
| A3S5 | 3101-2498 | 3 | | SWITCH-PB DPDT ALTNG .25A 115VAC | 28480 | 3101-2498 |
| A3S6 | 3101-2498 | 3 | | SWITCH-PB DPDT ALTNG .25A 115VAC | 28480 | 3101-2498 |
| A3S7 | 3101-2498 | 3 | | SWITCH-PB DPDT ALTNG .25A 115VAC | 28480 | 3101-2498 |
| A3S8 | 3101-2498 | 3 | | SWITCH-PB DPDT ALTNG .25A 115VAC | 28480 | 3101-2498 |
| A3S9 | 3101-2498 | 3 | | SWITCH-PB DPDT ALTNG .25A 115VAC | 28480 | 3101-2498 |
| A3S10 | 3101-2498 | 3 | | SWITCH-PB DPDT ALTNG .25A 115VAC | 28480 | 3101-2498 |
| A3S11 | | | | NSR, PART OF R66 | | |
| A3S12 | 3101-2498 | 3 | | SWITCH-PB DPDT ALTNG .25A 115VAC | 28480 | 3101-2498 |
| A3U1 | 1826-0600 | 9 | 2 | IC OP AMP LOW-BIAS-H-IMPD QUAD 14-DIP-P | 01295 | TL074ACN |
| A3U2 | 1826-0570 | 2 | 2 | IC | 28480 | 1826-0570 |
| A3U3 | 1826-0035 | 4 | 2 | IC OP AMP LOW-DRIFT TO-99 PKG | 27014 | LM308AH |
| A3U4 | 1826-0035 | 4 | | IC OP AMP LOW-DRIFT TO-99 PKG | 27014 | LM308AH |
| A3U5 | 1826-0570 | 2 | | IC | 28480 | 1826-0570 |
| A3U6 | 1826-0600 | 9 | | IC OP AMP LOW-BIAS-H-IMPD QUAD 14-DIP-P | 01295 | TL074ACN |
| | | | 1 | A3 MISCELLANEOUS PARTS | | |
| | 0340-0092 | 2 | 4 | TERMINAL SOLDER SPCL-FDTHRU PRESS-MTG | 28480 | 0340-0092 |
| | 0360-1682 | 0 | 1 | TERMINAL-TEST SGL-TUR PRESS-MTG | 28480 | 0360-1682 |
| | 1205-0061 | 0 | 2 | HEAT SINK TO-5/TO-39-CS | 28480 | 1205-0061 |
| | 4040-1616 | 6 | 2 | STANDOFF-LED | 28480 | 4040-1616 |
| | 5041-0234 | 5 | 8 | CAP-PUSHBUTTON LIGHT GRAY | 28480 | 5041-0234 |
| | 5041-0300 | 6 | 2 | CAP-PUSHBUTTON DARK GRAY | 28480 | 5041-0300 |
| | 2950-0035 | 8 | 2 | NUT-HEX-DBL-CHAM 0.4688-32 X 9/16 (BNC MTG) | 00000 | ORDER BY DESCRIPTION |

See introduction to this section for ordering information
*Indicates factory selected value

Table 6-2. Replaceable Parts (Continued)

| Reference Designation | HP Part Number | C D | Qty | Description | Mfr Code | Mfr Part Number |
|-----------------------|----------------|-----|-----|--|----------|---------------------|
| A4 | 05335-60004 | 0 | 1 | BOARD ASSEMBLY-MAIN LOGIC(SERIES 2224) | 28480 | 05335-60004 |
| A4C1 | 0160-4554 | 0 | 17 | CAPACITOR-FXD .01UF +-20% 50VDC CER | 28480 | 0160-4554 |
| A4C2 | 0140-0234 | 7 | 2 | CAPACITOR-FXD 500PF +-1% 300VDC MICA | 72136 | DM15F501F0300WV1C |
| A4C3 | 0140-0234 | 0 | | CAPACITOR-FXD 500PF +-1% 300VDC MICA | 72136 | DM15F501F0300WV1C |
| A4C4 | 0160-0576 | 5 | 9 | CAPACITOR-FXD .1UF +-20% 50VDC CER | 28480 | 0160-0576 |
| A4C5 | 0160-0576 | 5 | | CAPACITOR-FXD .1UF +-20% 50VDC CER | 28480 | 0160-0576 |
| A4C6 | 0121-0061 | 1 | 1 | CAPACITOR-V TRMR-CER 5.5-10PF 350V | 52763 | 304322 5.5/10PF NPD |
| A4C7 | 0160-0576 | 5 | | CAPACITOR-FXD .1UF +-20% 50VDC CER | 28480 | 0160-0576 |
| A4C8 | 0160-3879 | 7 | 9 | CAPACITOR-FXD .01UF +-20% 100VDC CER | 28480 | 0160-3879 |
| A4C9 | 0160-0368 | 3 | 1 | CAPACITOR-FXD 16PF +-5% 500VDC MICA | 28480 | 0160-0368 |
| A4C10 | 0160-3879 | 7 | | CAPACITOR-FXD .01UF +-20% 100VDC CER | 28480 | 0160-3879 |
| A4C11 | 0160-3879 | 7 | | CAPACITOR-FXD .01UF +-20% 100VDC CER | 28480 | 0160-3879 |
| A4C12 | 0160-4554 | 7 | | CAPACITOR-FXD .01UF +-20% 50VDC CER | 28480 | 0160-4554 |
| A4C13 | 0160-4554 | 7 | | CAPACITOR-FXD .01UF +-20% 50VDC CER | 28480 | 0160-4554 |
| A4C14 | 0160-3879 | 7 | | CAPACITOR-FXD .01UF +-20% 100VDC CER | 28480 | 0160-3879 |
| A4C15 | 0160-3879 | 7 | | CAPACITOR-FXD .01UF +-20% 100VDC CER | 28480 | 0160-3879 |
| A4C16 | 0160-0576 | 5 | | CAPACITOR-FXD .1UF +-20% 50VDC CER | 28480 | 0160-0576 |
| A4C17 | 0160-2222 | 2 | 2 | CAPACITOR-FXD 1500PF +-5% 300VDC MICA | 28480 | 0160-2222 |
| A4C18 | 0160-2230 | 2 | 1 | CAPACITOR-FXD 3300PF +-5% 300VDC MICA | 28480 | 0160-2230 |
| A4C19 | 0180-0155 | 8 | 2 | CAPACITOR-FXD 2.2UF+-20% 20VDC TA | 56289 | 150D225X0020A2 |
| A4C20 | 0160-4554 | 7 | | CAPACITOR-FXD .01UF +-20% 50VDC CER | 28480 | 0160-4554 |
| A4C21 | 0160-4554 | 7 | | CAPACITOR-FXD .01UF +-20% 50VDC CER | 28480 | 0160-4554 |
| A4C22 | 0160-0576 | 5 | | CAPACITOR-FXD .1UF +-20% 50VDC CER | 28480 | 0160-0576 |
| A4C23 | 0160-2222 | 2 | | CAPACITOR-FXD 1500PF +-5% 300VDC MICA | 28480 | 0160-2222 |
| A4C24 | 0160-3879 | 7 | | CAPACITOR-FXD .01UF +-20% 100VDC CER | 28480 | 0160-3879 |
| A4C25 | 0160-2224 | 4 | 1 | CAPACITOR-FXD 1800PF +-5% 300VDC MICA | 28480 | 0160-2224 |
| A4C26 | 0160-4554 | 7 | | CAPACITOR-FXD .01UF +-20% 50VDC CER | 28480 | 0160-4554 |
| A4C27 | 0160-4554 | 7 | | CAPACITOR-FXD .01UF +-20% 50VDC CER | 28480 | 0160-4554 |
| A4C28 | 0160-4554 | 7 | | CAPACITOR-FXD .01UF +-20% 50VDC CER | 28480 | 0160-4554 |
| A4C29 | 0160-0576 | 5 | | CAPACITOR-FXD .1UF +-20% 50VDC CER | 28480 | 0160-0576 |
| A4C30 | 0160-0576 | 5 | | CAPACITOR-FXD .1UF +-20% 50VDC CER | 28480 | 0160-0576 |
| A4C31 | 0160-0576 | 5 | | CAPACITOR-FXD .1UF +-20% 50VDC CER | 28480 | 0160-0576 |
| A4C32 | 0160-4554 | 7 | | CAPACITOR-FXD .01UF +-20% 50VDC CER | 28480 | 0160-4554 |
| A4C33 | 0160-3879 | 7 | | CAPACITOR-FXD .01UF +-20% 100VDC CER | 28480 | 0160-3879 |
| A4C34 | 0160-3879 | 7 | | CAPACITOR-FXD .01UF +-20% 100VDC CER | 28480 | 0160-3879 |
| A4C35 | 0160-4554 | 7 | | CAPACITOR-FXD .01UF +-20% 50VDC CER | 28480 | 0160-4554 |
| A4C36 | 0180-2662 | 6 | 1 | CAPACITOR-FXD 10UF+-10% 10VDC TA | 25088 | D4R7GS1A10K |
| A4C37 | 0160-4554 | 7 | | CAPACITOR-FXD .01UF +-20% 50VDC CER | 28480 | 0160-4554 |
| A4C38 | 0160-0575 | 4 | 1 | CAPACITOR-FXD .047UF +-20% 50VDC CER | 28480 | 0160-0575 |
| A4C39 | 0160-4554 | 7 | | CAPACITOR-FXD .01UF +-20% 50VDC CER | 28480 | 0160-4554 |
| A4C40 | 0160-4554 | 7 | | CAPACITOR-FXD .01UF +-20% 50VDC CER | 28480 | 0160-4554 |
| A4C41 | 0160-4554 | 7 | | CAPACITOR-FXD .01UF +-20% 50VDC CER | 28480 | 0160-4554 |
| A4C42 | 0180-2929 | 8 | 1 | CAPACITOR-FXD 68UF+-10% 10VDC TA | 28480 | 0180-2929 |
| A4C43 | 0160-4554 | 7 | | CAPACITOR-FXD .01UF +-20% 50VDC CER | 28480 | 0160-4554 |
| A4C44 | 0160-0576 | 5 | | CAPACITOR-FXD .1UF +-20% 50VDC CER | 28480 | 0160-0576 |
| A4C45 | 0160-4554 | 7 | | CAPACITOR-FXD .01UF +-20% 50VDC CER | 28480 | 0160-4554 |
| A4C46 | 0160-3879 | 7 | | CAPACITOR-FXD .01UF +-20% 100VDC CER | 28480 | 0160-3879 |
| A4C47 | 0180-0230 | 0 | 1 | CAPACITOR-FXD 1UF+-20% 50VDC TA | 56289 | 150D105X0050A2 |
| A4C48 | 0160-4554 | 7 | | CAPACITOR-FXD .01UF +-20% 50VDC CER | 28480 | 0160-4554 |
| A4C49 | 0180-0155 | 8 | | CAPACITOR-FXD 2.2UF+-20% 20VDC TA | 56289 | 150D225X0020A2 |
| A4C50 | 0160-3875 | 3 | 2 | CAPACITOR-FXD 22PF +-5% 200VDC CER 0+-30 | 28480 | 0160-3875 |
| A4C51 | 0160-3875 | 3 | | CAPACITOR-FXD 22PF +-5% 200VDC CER 0+-30 | 20480 | 0160-3875 |
| A4C52 | 0180-0374 | 3 | 1 | CAPACITOR-FXD 10UF+-10% 20VDC TA | 56289 | 150D106X9020B2 |
| A4CR1 | 1901-0050 | 3 | 8 | DIODE-SWITCHING 80V 200MA 2NS DO-35 | 28480 | 1901-0050 |
| A4CR2 | 1901-0050 | 3 | | DIODE-SWITCHING 80V 200MA 2NS DO-35 | 28480 | 1901-0050 |
| A4CR3 | 1901-0535 | 9 | 3 | DIODE-SM SIG SCHOTTKY | 28480 | 1901-0535 |
| A4CR4 | 1901-0050 | 3 | | DIODE-SWITCHING 80V 200MA 2NS DO-35 | 28480 | 1901-0050 |
| A4CR5 | 1901-0050 | 3 | | DIODE-SWITCHING 80V 200MA 2NS DO-35 | 28480 | 1901-0050 |
| A4CR6 | 1901-0050 | 3 | | DIODE-SWITCHING 80V 200MA 2NS DO-35 | 28480 | 1901-0050 |
| A4CR7 | 1901-0050 | 3 | | DIODE-SWITCHING 80V 200MA 2NS DO-35 | 28480 | 1901-0050 |
| A4CR8 | 1901-0050 | 3 | | DIODE-SWITCHING 80V 200MA 2NS DO-35 | 28480 | 1901-0050 |
| A4CR9 | 1901-0050 | 3 | | DIODE-SWITCHING 80V 200MA 2NS DO-35 | 28480 | 1901-0050 |
| A4CR10 | 1901-0535 | 9 | | DIODE-SM SIG SCHOTTKY | 28480 | 1901-0535 |
| A4CR11 | 1901-0535 | 9 | | DIODE-SM SIG SCHOTTKY | 28480 | 1901-0535 |
| A4DS1 | 1990-0627 | 7 | 1 | LED-LAMP LUM-INT=1MCD IF=20MA-MAX RED | 28480 | 1990-0627 |
| A4J1 | 1200-0482 | 9 | 1 | SOCKET-IC 16-CONT DIP-SLDR | 28480 | 1200-0482 |
| A4J2 | 1251-6608 | 0 | 2 | CONNECTOR 16-PIN M POST TYPE | 28480 | 1251-6608 |
| A4J3 | 1251-6608 | 0 | | CONNECTOR 16-PIN M POST TYPE | 28480 | 1251-6608 |
| A4L1 | 9100-0348 | 2 | 1 | INDUCTOR RF-CH-HLD 1UH 1% .166DX,3B5LG | 28480 | 9100-0348 |

See introduction to this section for ordering information
*Indicates factory selected valueReproduced with permission,
Courtesy of Agilent Technologies Inc.

Table 6-2. Replaceable Parts (Continued)

| Reference Designation | HP Part Number | C D | Qty | Description | Mfr Code | Mfr Part Number |
|-----------------------|----------------|-----|-----|--------------------------------------|----------|---------------------|
| A4Q1 | 1854-0215 | 1 | 7 | TRANSISTOR NPN SI PD=350MW FT=300MHZ | 04713 | 2N3904 |
| A4Q2 | 1854-0215 | 1 | | TRANSISTOR NPN SI PD=350MW FT=300MHZ | 04713 | 2N3904 |
| A4Q3 | 1854-0215 | 1 | | TRANSISTOR NPN SI PD=350MW FT=300MHZ | 04713 | 2N3904 |
| A4Q4 | | | | NOT ASSIGNED | | |
| A4Q5 | | | | NOT ASSIGNED | | |
| A4Q6 | 1853-0015 | 7 | 4 | TRANSISTOR PNP SI PD=200MW FT=500MHZ | 28480 | 1853-0015 |
| A4Q7 | 1853-0015 | 7 | | TRANSISTOR PNP SI PD=200MW FT=500MHZ | 28480 | 1853-0015 |
| A4Q8 | 1853-0015 | 7 | | TRANSISTOR PNP SI PD=200MW FT=500MHZ | 28480 | 1853-0015 |
| A4Q9 | 1853-0015 | 7 | | TRANSISTOR PNP SI PD=200MW FT=500MHZ | 28480 | 1853-0015 |
| A4Q10 | 1854-0215 | 1 | | TRANSISTOR NPN SI PD=350MW FT=300MHZ | 04713 | 2N3904 |
| A4Q11 | 1854-0215 | 1 | | TRANSISTOR NPN SI PD=350MW FT=300MHZ | 04713 | 2N3904 |
| A4Q12 | 1854-0215 | 1 | | TRANSISTOR NPN SI PD=350MW FT=300MHZ | 04713 | 2N3904 |
| A4Q13 | 1854-0215 | 1 | | TRANSISTOR NPN SI PD=350MW FT=300MHZ | 04713 | 2N3904 |
| A4R1 | 0757-0394 | 0 | 3 | RESISTOR 51.1 1% .125W F TC=0+-100 | 24546 | C4-1/8-T0-51R1-F |
| A4R2 | 1810-0364 | 9 | 1 | NETWORK-RES 6-SIP470.0 OHM X 5 | 01121 | 286A471 |
| A4R3 | 0757-0419 | 0 | 4 | RESISTOR 681 1% .125W F TC=0+-100 | 24546 | C4-1/8-T0-681R-F |
| A4R4 | 0757-0419 | 0 | | RESISTOR 681 1% .125W F TC=0+-100 | 24546 | C4-1/8-T0-681R-F |
| A4R5 | 0698-3438 | 3 | 1 | RESISTOR 147 1% .125W F TC=0+-100 | 24546 | C4-1/8-T0-147R-F |
| A4R6 | 0698-0082 | 7 | 1 | RESISTOR 464 1% .125W F TC=0+-100 | 24546 | C4-1/8-T0-4640-F |
| A4R7 | 1810-0203 | 5 | 1 | NETWORK-RES 8-SIP470.0 OHM X 7 | 01121 | 286A471 |
| A4R8 | 0757-0420 | 3 | 2 | RESISTOR 750 1% .125W F TC=0+-100 | 24546 | C4-1/8-T0-751-F |
| A4R9 | 0757-0280 | 3 | 14 | RESISTOR 1K 1% .125W F TC=0+-100 | 24546 | C4-1/8-T0-1001-F |
| A4R10 | | | | NOT ASSIGNED | | |
| A4R11 | 0757-0420 | 3 | | RESISTOR 750 1% .125W F TC=0+-100 | 24546 | C4-1/8-T0-751-F |
| A4R12 | 0698-7211 | 8 | 2 | RESISTOR 90.9 1% .05W F TC=0+-100 | 24546 | C3-1/8-T0-90R9-F |
| A4R13 | 1810-0205 | 7 | 1 | NETWORK-RES 8-SIP4.7K OHM X 7 | 01121 | 286A472 |
| A4R14 | 1810-0318 | 3 | 1 | NETWORK-RES 6-SIP1.0K OHM X 5 | 01121 | 286A102 |
| A4R15 | 0757-0419 | 0 | | RESISTOR 681 1% .125W F TC=0+-100 | 24546 | C4-1/8-T0-681R-F |
| A4R16 | 0757-0419 | 0 | | RESISTOR 681 1% .125W F TC=0+-100 | 24546 | C4-1/8-T0-681R-F |
| A4R17 | 0757-0280 | 3 | | RESISTOR 1K 1% .125W F TC=0+-100 | 24546 | C4-1/8-T0-1001-F |
| A4R18 | 0698-3444 | 1 | 1 | RESISTOR 316 1% .125W F TC=0+-100 | 24546 | C4-1/8-T0-316R-F |
| A4R19 | 0698-7238 | 9 | 1 | RESISTOR 1.21K 1% .05W F TC=0+-100 | 24546 | C3-1/8-T0-1211-F |
| A4R20 | 0757-0394 | 0 | | RESISTOR 51.1 1% .125W F TC=0+-100 | 24546 | C4-1/8-T0-51R1-F |
| A4R21 | 0698-7211 | 8 | | RESISTOR 90.9 1% .05W F TC=0+-100 | 24546 | C3-1/8-T0-90R9-F |
| A4R22 | 0757-0401 | 0 | 2 | RESISTOR 100 1% .125W F TC=0+-100 | 24546 | C4-1/8-T0-101-F |
| A4R23 | 0757-0280 | 3 | | RESISTOR 1K 1% .125W F TC=0+-100 | 24546 | C4-1/8-T0-1001-F |
| A4R24 | 0757-0280 | 3 | | RESISTOR 1K 1% .125W F TC=0+-100 | 24546 | C4-1/8-T0-1001-F |
| A4R25 | 0757-0280 | 3 | | RESISTOR 1K 1% .125W F TC=0+-100 | 24546 | C4-1/8-T0-1001-F |
| A4R26 | 0757-0280 | 3 | | RESISTOR 1K 1% .125W F TC=0+-100 | 24546 | C4-1/8-T0-1001-F |
| A4R27 | 0757-0280 | 3 | | RESISTOR 1K 1% .125W F TC=0+-100 | 24546 | C4-1/8-T0-1001-F |
| A4R28 | 0757-0401 | 0 | | RESISTOR 100 1% .125W F TC=0+-100 | 24546 | C4-1/8-T0-101-F |
| A4R29 | 0757-0280 | 3 | | RESISTOR 1K 1% .125W F TC=0+-100 | 24546 | C4-1/8-T0-1001-F |
| A4R30 | 0757-0465 | 6 | 2 | RESISTOR 100K 1% .125W F TC=0+-100 | 24546 | C4-1/8-T0-100K-F |
| A4R31 | 0757-0465 | 6 | | RESISTOR 100K 1% .125W F TC=0+-100 | 24546 | C4-1/8-T0-100K-F |
| A4R32 | 0757-0394 | 0 | | RESISTOR 51.1 1% .125W F TC=0+-100 | 24546 | C4-1/8-T0-51R1-F |
| A4R33 | 0698-3440 | 7 | 1 | RESISTOR 196 1% .125W F TC=0+-100 | 24546 | C4-1/8-T0-196R-F |
| A4R34 | 0698-3431 | 6 | 3 | RESISTOR 23.7 1% .125W F TC=0+-100 | 03888 | PME55-1/8-T0-23R7-F |
| A4R35 | 0698-0084 | 9 | 1 | RESISTOR 2.15K 1% .125W F TC=0+-100 | 24546 | C4-1/8-T0-2151-F |
| A4R36 | 0698-3431 | 6 | | RESISTOR 23.7 1% .125W F TC=0+-100 | 03888 | PME55-1/8-T0-23R7-F |
| A4R37 | 0698-3431 | 6 | | RESISTOR 23.7 1% .125W F TC=0+-100 | 03888 | PME55-1/8-T0-23R7-F |
| A4R38* | 0757-0441 | 8 | 2 | RESISTOR 8.25K 1% .125W F TC=0+-100 | 24546 | C4-1/8-T0-8251-F |
| A4R39* | 0757-0441 | 8 | | RESISTOR 8.25K 1% .125W F TC=0+-100 | 24546 | C4-1/8-T0-8251-F |
| A4R40 | 1810-0374 | 1 | 1 | NETWORK-RES 8-SIP1.0K OHM X 4 | 01121 | 286A102 |
| A4R41 | 0757-0280 | 3 | | RESISTOR 1K 1% .125W F TC=0+-100 | 24546 | C4-1/8-T0-1001-F |
| A4R42 | 0757-0280 | 3 | | RESISTOR 1K 1% .125W F TC=0+-100 | 24546 | C4-1/8-T0-1001-F |
| A4R43 | 0757-0442 | 9 | 4 | RESISTOR 10K 1% .125W F TC=0+-100 | 24546 | C4-1/8-T0-100K-F |
| A4R44 | 0757-0442 | 9 | | RESISTOR 10K 1% .125W F TC=0+-100 | 24546 | C4-1/8-T0-100K-F |
| A4R45 | 0757-0442 | 9 | | RESISTOR 10K 1% .125W F TC=0+-100 | 24546 | C4-1/8-T0-100K-F |
| A4R46 | 0757-0280 | 3 | | RESISTOR 1K 1% .125W F TC=0+-100 | 24546 | C4-1/8-T0-1001-F |
| A4R47 | 0757-0442 | 9 | | RESISTOR 10K 1% .125W F TC=0+-100 | 24546 | C4-1/8-T0-100K-F |
| A4R48 | 1810-0206 | 8 | 1 | NETWORK-RES 8-SIP10.0K OHM X 7 | 01121 | 286A103 |
| A4R49 | 1810-0365 | 0 | 1 | NETWORK-RES 6-SIP2.2K OHM X 5 | 01121 | 286A222 |
| A4R50 | 0757-0438 | 3 | 2 | RESISTOR 5.11K 1% .125W F TC=0+-100 | 24546 | C4-1/8-T0-5111-F |
| A4R51 | 0757-0438 | 3 | | RESISTOR 5.11K 1% .125W F TC=0+-100 | 24546 | C4-1/8-T0-5111-F |
| A4R52 | 0757-1094 | 9 | 1 | RESISTOR 1.47K 1% .125W F TC=0+-100 | 24546 | C4-1/8-T0-1471-F |
| A4R53 | 0757-0280 | 3 | | RESISTOR 1K 1% .125W F TC=0+-100 | 24546 | C4-1/8-T0-1001-F |
| A4R54 | 0757-0280 | 3 | | RESISTOR 1K 1% .125W F TC=0+-100 | 24546 | C4-1/8-T0-1001-F |
| A4R55 | 0698-7250 | 5 | 1 | RESISTOR 3.83K 1% .05W F TC=0+-100 | 24546 | C3-1/8-T0-3831-F |
| A4S1 | 3101-0680 | 1 | 1 | SWITCH-PB DPDT ALTN 4A 250VAC | 28480 | 3101-0680 |
| A4U1 | 1820-0802 | 1 | 1 | IC GATE ECL NOR QUAD 2-INP | 04713 | MC10102P |
| A4U2 | 1820-0810 | 1 | 1 | IC RCVR ECL LINE RCVR TPL 2-INP | 04713 | MC10116P |
| A4U3 | 1820-1052 | 5 | 1 | IC XLTR ECL ECL-T0-TTL QUAD 2-INP | 04713 | MC10125U |
| A4U4 | 1826-0210 | 7 | 2 | IC COMPARTOR HS 14-DIP-P PKG | 27014 | LM361N |
| A4U5 | 1826-0210 | 7 | | IC COMPARTOR HS 14-DIP-P PKG | 27014 | LM361N |

See introduction to this section for ordering information
*Indicates factory selected value

Table 6-2. Replaceable Parts (Continued)

| Reference Designation | HP Part Number | C D | Qty | Description | Mfr Code | Mfr Part Number |
|------------------------|----------------|--------|-----|--|----------|-----------------|
| A4U6 | 1820-2312 | 2 | 1 | IC-MULTIPLE REGISTER COUNTER | 28480 | 1820-2312 |
| A4U7 | 1820-2075 | 4 | 1 | IC MISC TTL LS | 01295 | SN74LS245N |
| A4U8 | 1820-1989 | 7 | 2 | IC CNTR TTL LS BIN DUAL 4-BIT | 07263 | 74LS393PC |
| A4U9 | 1820-1438 | 1 | 2 | IC MUXR/DATA-SEL TTL LS 2-TO-1-LINE QUAD | 01295 | SN74LS257AN |
| A4U10 | 1820-1281 | 2 | 1 | IC DCDR TTL LS 2-TO-4-LINE DUAL 2-INP | 01295 | SN74LS139N |
| A4U11 | 1820-1144 | 6 | 1 | IC GATE TTL LS NOR QUAD 2-INP | 01295 | SN74LS02N |
| A4U12 | 1820-1416 | 5 | 1 | IC SCHMITT-TRIG TTL LS INV HEX 1-INP | 01295 | SN74LS14N |
| A4U13 | 1820-1989 | 7 | 2 | IC CNTR TTL LS BIN DUAL 4-BIT | 07263 | 74LS393PC |
| A4U14 | 1820-1438 | 1 | 2 | IC MUXR/DATA-SEL TTL LS 2-TO-1-LINE QUAD | 01295 | SN74LS257AN |
| A4U15 | 1820-2024 | 3 | 2 | IC DRVR TTL LS LINE DRVR OCTL | 01295 | SN74LS244N |
| A4U16 | 1820-2866 | 1 | 2 | SOCKET-IC 20-CONT DIP DIP-SLDR | 28480 | 1820-2866 |
| A4U17 | 1820-1112 | 8 | 2 | IC CMOS BI-DIRECTIONAL BUS TRANSCEIVER | 01295 | SN74LS74AN |
| A4U18 | 1820-1112 | 8 | 2 | IC FF TTL LS D-TYPE POS-EDGE-TRIG | 01295 | SN74LS74AN |
| A4U19 | 1820-1240 | 3 | 1 | IC DCDR TTL S 3-TO-8-LINE 3-INP | 01295 | SN74LS138N |
| A4U20 | 1820-1202 | 7 | 1 | IC GATE TTL LS NAND TPL 3-INP | 01295 | SN74LS10N |
| A4U21 | 1820-1197 | 9 | 1 | IC GATE TTL LS NAND QUAD 2-INP | 01295 | SN74LS00N |
| A4U22 | 1818-1249 | 7 | 1 | IC NMOS 65536 (64K) ROM 450-NS 3-S | 55576 | SYP2364 MASKED |
| A4U23 | 1818-1250 | 8 | 1 | IC NMOS 65536 (64K) ROM 450-NS 3-S | 55576 | SYP2364 MASKED |
| A4U24 | 1820-2866 | 1 | 2 | SOCKET-IC 20-CONT DIP DIP-SLDR | 28480 | 1820-2866 |
| A4U25 | 1818-0381 | 6 | 2 | IC NMOS 1024 (1K) STAT RAM 250-NS | 55576 | SYP2111A-2 |
| A4U26 | 1818-0381 | 6 | 2 | IC NMOS 1024 (1K) STAT RAM 250-NS | 55576 | SYP2111A-2 |
| A4U27 | 1820-2024 | 3 | 2 | SOCKET-IC 20-CONT DIP DIP-SLDR | 01295 | SN74LS244N |
| A4U28 | 1820-2099 | 2 | 1 | IC DRVR TTL LS LINE DRVR OCTL | 04713 | MC6802P |
| A4U29 | 1826-0275 | 4 | 1 | IC 78L12A V RGLTR TO-92 | 04713 | MC78L12ACP |
| A4U30 | 1858-0040 | 8 | 1 | TRANSISTOR ARRAY 16-PIN PLSTC DIP | 3L585 | CA3127E |
| A4U31 | 1858-0063 | 5 | 1 | TRANSISTOR ARRAY 14-PIN PLSTC DIP | 3L585 | CA3102E |
| A4W1 | 8159-0005 | 0 | 1 | WIRE JUMPER 22 AWG | 28480 | 8159-0005 |
| A4XA7 | 1251-2026 | 8 | 1 | CONNECTOR-PC EDGE 18-CONT/ROW 2-ROWS | 28480 | 1251-2026 |
| A4XA15 | 1251-2035 | 9 | 1 | CONNECTOR-PC EDGE 15-CONT/ROW 2-ROWS | 28480 | 1251-2035 |
| A4XA2P1 | 1251-3076 | 0 | 1 | CONNECTOR-PC EDGE 18-CONT/ROW 2-ROWS | 28480 | 1251-3076 |
| A4XU6 | 1200-0682 | 1 | 3 | SOCKET-IC 40-CONT DIP DIP-SLDR | 28480 | 1200-0682 |
| A4XU7,XU16,XU24,XU27 | 1200-0825 | 4 | 3 | SOCKET-IC 20-CONT DIP DIP-SLDR | 28480 | 1200-0825 |
| A4XU22 | 1200-0912 | 0 | 3 | SOCKET-IC 24-CONT DIP DIP-SLDR | 28480 | 1200-0912 |
| A4XU23 | 1200-0912 | 0 | 3 | SOCKET-IC 24-CONT DIP DIP-SLDR | 28480 | 1200-0912 |
| A4XU28 | 1200-0682 | 1 | 3 | SOCKET-IC 40-CONT DIP DIP-SLDR | 28480 | 1200-0682 |
| A4XY1 | 1200-0475 | 0 | 3 | CONNECTOR-SGL CONT SKT .017-IN-BSC-SZ | 28480 | 1200-0475 |
| A4Y1 | 0410-0423 | 2 | 1 | CRYSTAL-QUARTZ 10.000 MHZ | 28480 | 0410-0423 |
| A4Y2 | 0410-0465 | 2 | 1 | CRYSTAL-QUARTZ 4.00000 MHZ HC-6/U-HLDR | 28480 | 0410-0465 |
| A4 MISCELLANEOUS PARTS | | | | | | |
| A4H31 | 1400-0531 | 3 | 2 | CABLE CLAMP-PLASTIC SELF ADHESIVE | 28480 | 1400-0531 |
| | 0360-1682 | 0 | 2 | TERMINAL-STUD SSL-TUR PRESS-MTG | 28480 | 0360-1682 |
| | 1251-4707 | 6 | 10 | CONNECTOR-SGL CONT P IN .031-IN-BSC-SZ | 28480 | 1251-4707 |
| | 5040-0201 | 4 | 1 | CAP-PUSHBUTTON CHALK WHITE | 28480 | 5040-0201 |

See introduction to this section for ordering information
*Indicates factory selected valueReproduced with permission,
Courtesy of Agilent Technologies Inc.

Table 6-2. Replaceable Parts (Continued)

| Reference Designation | HP Part Number | C D | Qty | Description | Mfr Code | Mfr Part Number |
|-----------------------|----------------|-----|-----|---|----------|------------------|
| A5 | 05335-60005 | 1 | 1 | BOARD ASSEMBLY-DISPLAY (SERIES 2224) | 28480 | 05335-60005 |
| A5C1 | | | | NOT ASSIGNED | | |
| A5C2 | 0160-3879 | 7 | 4 | CAPACITOR-FXD .01UF +-20% 100VDC CER | 28480 | 0160-3879 |
| A5C3 | 0180-0137 | 6 | 1 | CAPACITOR-FXD 100UF+-20% 10VDC TA | 56289 | 150D107X0010R2 |
| A5C4 | 0160-3879 | 7 | | CAPACITOR-FXD .01UF +-20% 100VDC CER | 28480 | 0160-3879 |
| A5C5 | 0160-3879 | 7 | | CAPACITOR-FXD .01UF +-20% 100VDC CER | 28480 | 0160-3879 |
| A5C6 | 0160-3879 | 7 | | CAPACITOR-FXD .01UF +-20% 100VDC CER | 28480 | 0160-3879 |
| A5D51 | 1990-0574 | 3 | 13 | DISPLAY-NUM-SEG 1-CHAR 43-H RED | 28480 | 5082-7651 |
| A5D52 | 1990-0574 | 3 | | DISPLAY-NUM-SEG 1-CHAR 43-H RED | 28480 | 5082-7651 |
| A5D53 | 1990-0574 | 3 | | DISPLAY-NUM-SEG 1-CHAR 43-H RED | 28480 | 5082-7651 |
| A5D54 | 1990-0574 | 3 | | DISPLAY-NUM-SEG 1-CHAR 43-H RED | 28480 | 5082-7651 |
| A5D55 | 1990-0574 | 3 | | DISPLAY-NUM-SEG 1-CHAR 43-H RED | 28480 | 5082-7651 |
| A5D56 | 1990-0574 | 3 | | DISPLAY-NUM-SEG 1-CHAR 43-H RED | 28480 | 5082-7651 |
| A5D57 | 1990-0574 | 3 | | DISPLAY-NUM-SEG 1-CHAR 43-H RED | 28480 | 5082-7651 |
| A5D58 | 1990-0574 | 3 | | DISPLAY-NUM-SEG 1-CHAR 43-H RED | 28480 | 5082-7651 |
| A5D59 | 1990-0574 | 3 | | DISPLAY-NUM-SEG 1-CHAR 43-H RED | 28480 | 5082-7651 |
| A5D510 | 1990-0574 | 3 | | DISPLAY-NUM-SEG 1-CHAR 43-H RED | 28480 | 5082-7651 |
| A5D511 | 1990-0574 | 3 | | DISPLAY-NUM-SEG 1-CHAR 43-H RED | 28480 | 5082-7651 |
| A5D512 | 1990-0574 | 3 | | DISPLAY-NUM-SEG 1-CHAR 43-H RED | 28480 | 5082-7651 |
| A5D513 | 1990-0681 | 3 | 1 | DISPLAY-AN-SEG 1-CHAR 408-H RED | 28480 | 5082-7651 |
| A5D514 | 1990-0574 | 3 | | DISPLAY-NUM-SEG 1-CHAR 43-H RED | 28480 | 5082-7651 |
| A5D515- | | | | | | |
| A5D548 | 1990-0851 | 9 | 34 | LED-VISIBLE LUN-INT=1MCD IF=20MA-MAX | 28480 | 1990-0851 |
| A5D549 | 1990-0486 | 6 | 10 | LED-LAMP LUM-INT 1MCD IF=20MA-MAX RED | 28480 | 5082-4684 |
| A5D550 | 1990-0486 | 6 | | LED-LAMP LUM-INT 1MCD IF=20MA-MAX RED | 28480 | 5082-4684 |
| A5D551 | 1990-0486 | 6 | | LED-LAMP LUM-INT 1MCD IF=20MA-MAX RED | 28480 | 5082-4684 |
| A5D552 | 1990-0486 | 6 | | LED-LAMP LUM-INT 1MCD IF=20MA-MAX RED | 28480 | 5082-4684 |
| A5D553 | 1990-0486 | 6 | | LED-LAMP LUM-INT 1MCD IF=20MA-MAX RED | 28480 | 5082-4684 |
| A5D554 | 1990-0486 | 6 | | LED-LAMP LUM-INT 1MCD IF=20MA-MAX RED | 28480 | 5082-4684 |
| A5D555 | 1990-0486 | 6 | | LED-LAMP LUM-INT 1MCD IF=20MA-MAX RED | 28480 | 5082-4684 |
| A5D556 | 1990-0486 | 6 | | LED-LAMP LUM-INT 1MCD IF=20MA-MAX RED | 28480 | 5082-4684 |
| A5D557 | 1990-0486 | 6 | | LED-LAMP LUM-INT 1MCD IF=20MA-MAX RED | 28480 | 5082-4684 |
| A5D558 | 1990-0486 | 6 | | LED-LAMP LUM-INT 1MCD IF=20MA-MAX RED | 28480 | 5082-4684 |
| A5J1 | 1251-6608 | 0 | 1 | CONNECTOR-16 PIN MALE POST TYPE | 28480 | 1251-6608 |
| A5J2 | 1251-6023 | 3 | 1 | CONNECTOR-RT ANGLE 16-PIN MALE | 28480 | 1251-6023 |
| A5R1 | 0699-0069 | 2 | 1 | RESISTOR 2.15M 1% .125W F TC=0+-100 | 28480 | 0699-0069 |
| A5R2 | 0698-0084 | 9 | 1 | RESISTOR 2.15K 1% .125W F TC=0+-100 | 24546 | C4-1/8-T0-2151-F |
| A5R3 | 2100-3792 | 9 | 1 | RESISTOR-VAR CONTROL CC 1M 10% 10CW | 01121 | WP40632S105AA |
| A5R4 | 1810-0205 | 7 | 1 | NETWORK-RES B-SIP4.7K OHM X 7 | 31121 | 208A472 |
| A5R5 | 0757-0439 | 4 | 1 | RESISTOR 6.81K 1% .125W F TC=0+-100 | 24546 | C4-1/8-T0-6811-F |
| A5S1- | | | | | | |
| A5S34 | 5060-9436 | 7 | 34 | PUSHBUTTON SWITCH P.C. MOUNT | 28480 | 5060-9436 |
| A5U1 | 1820-2132 | 4 | 3 | IC DRVR CMOS LED DRVR | 32293 | ICM7218A |
| A5U2 | 1820-2132 | 4 | | IC DRVR CMOS LED DRVR | 32293 | ICM7218A |
| A5U3 | 1820-1207 | 2 | 1 | IC GATE TTL LS NAND B-IMP | 01295 | SN74LS30N |
| A5U4 | 1820-1195 | 7 | 1 | IC FF TTL LS D-TYPE POS-EDGE-TRIG COM | 01295 | SN74LS175N |
| A5U5 | 1820-1858 | 9 | 1 | IC FF TTL LS D-TYPE CCTL | 01295 | SN74LS377N |
| A5U6 | 1820-1641 | 8 | 1 | IC DRVR TTL LS BUS DRVR HEX 1-INP | 01295 | SN74LS365AN |
| A5U7 | 1820-2132 | 4 | | IC DRVR CMOS LED DRVR | 32293 | ICM7218A |
| A5W1 | 8159-0005 | 0 | 1 | WIRE JUMPER 22AWG W PVC INS. | 28480 | 8159-0005 |
| A5XDS1- | | | | | | |
| A5XDS14 | 1200-0483 | 0 | 14 | SOCKET-IC 14-CONT DIP-SLDR | 28480 | 1200-0483 |
| | | | | A5 MISCELLANEOUS PARTS | | |
| | 4040-1614 | 4 | 9 | STANDOFF-LED | 28480 | 4040-1614 |
| | 4040-1615 | 5 | 1 | STANDOFF-LED (GATE TIME DELAY) | 28480 | 4040-1615 |
| | 5041-0252 | 7 | 8 | SWITCH CAP 5/16 X 5/16 LITE GREY/L PIPE | 28480 | 5041-0252 |
| | 5041-0253 | 8 | 16 | SWITCH CAP 5/16 X 1/2 LITE GREY/L PIPE | 28480 | 5041-0253 |
| | 5041-0276 | 5 | 1 | SWITCH CAP 5/16 X 5/16 LITE GREY/LESS L | 28480 | 5041-0276 |
| | 5041-0450 | 7 | 3 | SWITCH CAP 5/16 X 5/16 BLU/L PIPE | 28480 | 5041-0450 |
| | 5041-0318 | 6 | 2 | SWITCH CAP 5/16 X 5/16 DK GRY/L PIPE | 28480 | 5041-0318 |
| | 5041-1732 | 0 | 1 | SWITCH CAP 5/16 X 1/2 (RESET) | 28480 | 5041-1732 |
| | 5041-0319 | 7 | 2 | SWITCH CAP 5/16 X 1/2 DK GRY/L PIPE | 28480 | 5041-0319 |
| | 5041-1733 | 1 | 1 | SWITCH CAP 5/16 X 1/2 (CHECK) | 28480 | 5041-1733 |

See introduction to this section for ordering information

*Indicates factory selected value

Reproduced with permission,
Courtesy of Agilent Technologies Inc.

Table 6-2. Replaceable Parts (Continued)

| Reference Designation | HP Part Number | C D | Qty | Description | Mfr Code | Mfr Part Number |
|-----------------------|----------------|-----|-----|---|----------|------------------|
| A6 | 05335-61006 | 4 | 1 | REAR BOARD ASSEMBLY (SERIES 2224) | 28480 | 05335-61006 |
| A6C1+ | 0160-4557 | 0 | 5 | CAPACITOR-FXD .1UF +-20% 50VDC CER +A6C1NOT IN ALL INST.-ADDED AT FACTORY WHEN NECESSARY. | 16299 | CAC04X7R104M050A |
| A6C2 | 0180-0210 | 6 | 3 | CAPACITOR-FXD 3.3UF+-20% 15VDC TA | 56289 | 150D335X0015A2 |
| A6C3 | 0160-4554 | 7 | 4 | CAPACITOR-FXD .01UF +-20% 50VDC CER | 28480 | 0160-4554 |
| A6C4 | 0180-0210 | 6 | | CAPACITOR-FXD 3.3UF+-20% 15VDC TA | 56289 | 150D335X0015A2 |
| A6C5 | 0160-4557 | 0 | | CAPACITOR-FXD .1UF +-20% 50VDC CER | 16299 | CAC04X7R104M050A |
| A6C6 | 0180-0210 | 6 | | CAPACITOR-FXD 3.3UF+-20% 15VDC TA | 56289 | 150D335X0015A2 |
| A6C7 | 0160-4557 | 0 | | CAPACITOR-FXD .1UF +-20% 50VDC CER | 16299 | CAC04X7R104M050A |
| A6C8 | 0160-3046 | 0 | 4 | CAPACITOR-FXD 250PF +-1% 100VDC MICA | 28480 | 0160-3046 |
| A6C10 | 0160-3874 | 2 | 2 | CAPACITOR-FXD 10PF +-1.5PF 200VDC CER | 28480 | 0160-3874 |
| A6C11 | 0160-3874 | 2 | | CAPACITOR-FXD 10PF +-1.5PF 200VDC CER | 28480 | 0160-3874 |
| A6C12 | 0160-4554 | 7 | | CAPACITOR-FXD .01UF +-20% 50VDC CER | 28480 | 0160-4554 |
| A6C13 | 0160-3046 | 0 | | CAPACITOR-FXD 250PF +-1% 100VDC MICA | 28480 | 0160-3046 |
| A6C14 | 0160-3046 | 0 | | CAPACITOR-FXD 250PF +-1% 100VDC MICA | 28480 | 0160-3046 |
| A6C15 | 0160-4554 | 7 | | CAPACITOR-FXD .01UF +-20% 50VDC CER | 28480 | 0160-4554 |
| A6C16 | 0160-4554 | 7 | | CAPACITOR-FXD .01UF +-20% 50VDC CER | 28480 | 0160-4554 |
| A6C17 | 0160-4557 | 0 | | CAPACITOR-FXD .1UF +-20% 50VDC CER | 16299 | CAC04X7R104M050A |
| A6C18 | 0160-4557 | 0 | | CAPACITOR-FXD .1UF +-20% 50VDC CER | 16299 | CAC04X7R104M050A |
| A6C19 | 0160-3046 | 0 | | CAPACITOR-FXD 250PF +-1% 100VDC MICA | 28480 | 0160-3046 |
| A6C20 | 0160-0682 | 4 | 1 | CAPACITOR-FXD 3.3PF +-1.5PF 200VDC CER | 28480 | 0160-0682 |
| A6CR1 | 1901-0050 | 3 | 5 | DIODE-SWITCHING 80V 200MA 2NS DO-35 | 28480 | 1901-0050 |
| A6CR2 | 1901-0535 | 9 | 1 | DIODE-SM SIG SCHOTTKY | 28480 | 1901-0535 |
| A6CR3 | 1901-0050 | 3 | | DIODE-SWITCHING 80V 200MA 2NS DO-35 | 28480 | 1901-0050 |
| A6CR4 | 1901-0050 | 3 | | DIODE-SWITCHING 80V 200MA 2NS DO-35 | 28480 | 1901-0050 |
| A6CR5 | 1901-0050 | 3 | | DIODE-SWITCHING 80V 200MA 2NS DO-35 | 28480 | 1901-0050 |
| A6CR6 | 1901-0050 | 3 | | DIODE-SWITCHING 80V 200MA 2NS DO-35 | 28480 | 1901-0050 |
| A6J1 | 1250-1453 | 1 | 6 | CONNECTOR-RF BNC FEM SGL-HOLE-RR 50 OHM | 28480 | 1250-1453 |
| A6J2 | 1250-1453 | 1 | | CONNECTOR-RF BNC FEM SGL-HOLE-RR 50 OHM | 28480 | 1250-1453 |
| A6J3 | 1250-1453 | 1 | | CONNECTOR-RF BNC FEM SGL-HOLE-RR 50 OHM | 28480 | 1250-1453 |
| A6J4 | 1250-1453 | 1 | | CONNECTOR-RF BNC FEM SGL-HOLE-RR 50 OHM | 28480 | 1250-1453 |
| A6J5 | 1250-1453 | 1 | | CONNECTOR-RF BNC FEM SGL-HOLE-RR 50 OHM | 28480 | 1250-1453 |
| A6J6 | 1250-1453 | 1 | | CONNECTOR-RF BNC FEM SGL-HOLE-RR 50 OHM | 28480 | 1250-1453 |
| A6J7 | 1200-0482 | 9 | 1 | SOCKET-IC 16-CONT DIP-SLDR | 28480 | 1200-0482 |
| A6L1 | 9100-0348 | 2 | 3 | INDUCTOR RF-CH-MLD 1UH 1% .166DX.365LG | 28480 | 9100-0348 |
| A6L2 | 9100-0348 | 2 | | INDUCTOR RF-CH-MLD 1UH 1% .166DX.365LG | 28480 | 9100-0348 |
| A6L3 | 9100-0348 | 2 | | INDUCTOR RF-CH-MLD 1UH 1% .166DX.365LG | 28480 | 9100-0348 |
| A6Q1 | 1854-0215 | 1 | 6 | TRANSISTOR NPN SI PD=350MW FT=300MHZ | 04713 | 2N3904 |
| A6Q2 | 1854-0215 | 1 | | TRANSISTOR NPN SI PD=350MW FT=300MHZ | 04713 | 2N3904 |
| A6Q3 | 1854-0215 | 1 | | TRANSISTOR NPN SI PD=350MW FT=300MHZ | 04713 | 2N3904 |
| A6Q4 | 1853-0036 | 2 | 1 | TRANSISTOR PNP SI PD=310MW FT=250MHZ | 28480 | 1853-0036 |
| A6Q5 | 1854-0215 | 1 | | TRANSISTOR NPN SI PD=350MW FT=300MHZ | 04713 | 2N3904 |
| A6Q6 | 1854-0215 | 1 | | TRANSISTOR NPN SI PD=350MW FT=300MHZ | 04713 | 2N3904 |
| A6Q7 | 1854-0215 | 1 | | TRANSISTOR NPN SI PD=350MW FT=300MHZ | 04713 | 2N3904 |
| A6R1 | 0757-0401 | 0 | 1 | RESISTOR 100 1% .125W F TC=0+-100 | 24546 | C4-1/8-T0-101-F |
| A6R2 | 0698-3162 | 0 | 1 | RESISTOR 46.4K 1% .125W F TC=0+-100 | 24546 | C4-1/8-T0-4642-F |
| A6R3 | 0757-0418 | 9 | 1 | RESISTOR 619 1% .125W F TC=0+-100 | 24546 | C4-1/8-T0-619R |
| †A6R5 | 1810-0367 | 2 | 1 | NETWORK-RES 6-SIP 4.7K OHM X5 | 01121 | 205A472 |
| †A6R7 | 0698-3439 | 4 | 1 | RESISTOR 178 1% .125W F TC=0+-100 | 24546 | C4-1/8-T0-178R-F |
| A6R8 | 0757-0280 | 3 | 4 | RESISTOR 1K 1% .125W F TC=0+-100 | 24546 | C4-1/8-T0-1001-F |
| A6R9 | 0698-3444 | 1 | 1 | RESISTOR 316 1% .125W F TC=0+-100 | 24546 | C4-1/8-T0-316R-F |
| A6R10 | 0757-0280 | 3 | | RESISTOR 1K 1% .125W F TC=0+-100 | 24546 | C4-1/8-T0-1001-F |
| A6R11 | 0757-0280 | 3 | | RESISTOR 1K 1% .125W F TC=0+-100 | 24546 | C4-1/8-T0-1001-F |
| †A6R13 | 0757-0280 | 3 | | RESISTOR 1K 1% .125W F TC=0+-100 | 24546 | C4-1/8-T0-1001-F |
| †A6R15 | 0757-0442 | 9 | 2 | RESISTOR 10K 1% .125W F TC=0+-100 | 24546 | C4-1/8-T0-1002-F |
| A6R16 | 0757-0178 | 8 | 1 | RESISTOR 100 1% .25W F TC=0+-100 | 24546 | C5-1/4-T0-101-F |
| A6R17 | 0757-1093 | 8 | 2 | RESISTOR 3K 1% .125W F TC=0+-100 | 24546 | C4-1/8-T0-3001-F |
| A6R18 | 0757-0439 | 4 | 1 | RESISTOR 6.81K 1% .125W F TC=0+-100 | 24546 | C4-1/8-T0-6811-F |
| A6R19 | 0757-0442 | 9 | | RESISTOR 10K 1% .125W F TC=0+-100 | 24546 | C4-1/8-T0-1002-F |
| A6R20 | 0757-1093 | 8 | | RESISTOR 3K 1% .125W F TC=0+-100 | 24546 | C4-1/8-T0-3001-F |
| A6R21 | 0698-3152 | 8 | 1 | RESISTOR 3.48K 1% .125W F TC=0+-100 | 24546 | C4-1/8-T0-3481-F |
| A6R22 | 2100-2497 | 9 | 1 | RESISTOR-TRMR 2K 10% C TOP-ADJ 1-TRN | 73138 | 82PR2K |
| A6R23 | 0698-3155 | 1 | 1 | RESISTOR 4.64K 1% .125W F TC=0+-100 | 24546 | C4-1/8-T0-4641-F |
| A6R24 | 0698-3450 | 9 | 1 | RESISTOR 42.2K 1% .125W F TC=0+-100 | 24546 | C4-1/8-T0-4222-F |
| A6S1 | 3101-1782 | 6 | 2 | SWITCH-TOGGLE SUB-MIN SPDT 250VAC | 28480 | 3101-1782 |
| A6S2 | 3101-1782 | 6 | | SWITCH-TOGGLE SUB-MIN SPDT 250VAC | 28480 | 3101-1782 |

†A6R4,R6,R12,R14 — NOT ASSIGNED

See introduction to this section for ordering information.

*Indicates factory selected value

Reproduced with permission,
Courtesy of Agilent Technologies Inc.

Table 6-2. Replaceable Parts (Continued)

| Reference Designation | HP Part Number | C D | Qty | Description | Mfr Code | Mfr Part Number |
|-----------------------|----------------|-----|-----|--|----------|----------------------|
| A7 | 05335-60007 | 3 | 1 | BOARD ASSEMBLY-HP-IB(SERIES 2224) | 28480 | 05335-60007 |
| A7C1 | 0160-3879 | 7 | 5 | CAPACITOR-FXD .01UF +-20% 100VDC CER | 28480 | 0160-3879 |
| A7C2 | 0160-3879 | 7 | | CAPACITOR-FXD .01UF +-20% 100VDC CER | 28480 | 0160-3879 |
| A7C3 | 0180-0374 | 3 | 1 | CAPACITOR-FXD 10UF+-10% 20VDC TA | 56289 | 150D106X9020B2 |
| A7C4 | 0160-3879 | 7 | | CAPACITOR-FXD .01UF +-20% 100VDC CER | 28480 | 0160-3879 |
| A7C5 | 0160-3879 | 7 | | CAPACITOR-FXD .01UF +-20% 100VDC CER | 28480 | 0160-3879 |
| A7C6 | 0160-3879 | 7 | | CAPACITOR-FXD .01UF +-20% 100VDC CER | 28480 | 0160-3879 |
| A7J1 | 1200-0482 | 9 | 4 | SOCKET-IC 16-CONT DIP-SLDR | 28480 | 1200-0482 |
| A7J2 | 1200-0482 | 9 | | SOCKET-IC 16-CONT DIP-SLDR | 28480 | 1200-0482 |
| A7R1 | 1810-0205 | 7 | 1 | NETWORK-RES 8-SIP4.7K OHM X 7 | 01121 | 208A472 |
| A7U1 | 1820-2219 | 8 | 1 | IC MICPROC-ACCESS NMOS 8-BIT | 04713 | MC68488P |
| A7U2 | 1820-1281 | 2 | 1 | IC DCDR TTL LS 2-TO-4-LINE DUAL 2-INP | 01295 | SN74LS139N |
| A7U3 | 1820-2058 | 3 | 4 | IC MISC TTL S QUAD | 07263 | MC3448AL |
| A7U4 | 1820-2058 | 3 | | IC MISC TTL S QUAD | 07263 | MC3448AL |
| A7U5 | 1820-1199 | 1 | 1 | IC INV TTL LS HEX 1-INP | 01295 | SN74LS04N |
| A7U6 | 1820-2058 | 3 | | IC MISC TTL S QUAD | 07263 | MC3448AL |
| A7U7 | 1820-2058 | 3 | | IC MISC TTL S QUAD | 07263 | MC3448AL |
| A7U8 | 1820-2024 | 3 | 1 | IC DRVR TTL LS LINE DRVR OCTL | 01295 | SN74LS244N |
| A7XU1 | 1200-0682 | 1 | 1 | SOCKET-IC 40-CONT DIP DIP-SLDR | 28480 | 1200-0682 |
| A8 | 05335-60008 | | | OPT. 020,DVM, REFER TO TABLE 6-4. | | |
| A9 | 05335-60009 | | | OPT. 030, CHAN C, REFER TO TABLE 6-5. | | |
| A10 | 05335-60010 | | | OPT. 040, REFER TO TABLE 6-6. | | |
| A11 | 05335-60011 | | | OPT. 040, REFER TO TABLE 6-6. | | |
| A12 | 05335-60012 | | | OPT. 040, REFER TO TABLE 6-6. | | |
| A13 | 0960-0443 | 1 | 1 | LINE MODULE- FILTERED | 28480 | 0960-0443 |
| A14 | 05370-60005 | 4 | 1 | BOARD ASSY,HP-IB CONNECTOR(SERIES 1748) | 28480 | 05370-60005 |
| A14H13 | 0380-0643 | 3 | 2 | STANDOFF-HEX .255-IN-LG 6-32THD | 00000 | ORDER BY DESCRIPTION |
| A14H14 | 2190-0034 | 5 | 2 | WASHER-LK HLCL NO. 10 .194-IN-ID | 28480 | 2190-0034 |
| A14H28 | 1530-1098 | 4 | 2 | CLEVIS 0.070-IN W SLT: 0.454-IN PIN CTR | 00000 | ORDER BY DESCRIPTION |
| A14J1 | 1200-0482 | 9 | | SOCKET-IC 16-CONT DIP-SLDR | 28480 | 1200-0482 |
| A14J2 | 1200-0482 | 9 | | SOCKET-IC 16-CONT DIP-SLDR | 28480 | 1200-0482 |
| A14J3 | 1251-3283 | 1 | 1 | CONNECTOR 24-PIN F MICRORIBBON | 28480 | 1251-3283 |
| A14S1 | 3101-1973 | 7 | 1 | SWITCH-SL 7-1A DIP-SLIDE-ASSY .1A 50VDC | 28480 | 3101-1973 |
| A14XS1 | 1200-0485 | 2 | 1 | SOCKET-IC 14-CONT DIP DIP-SLDR | 28480 | 1200-0485 |
| | | | | A14 MISCELLANEOUS PARTS | | |
| A15 | 10544 | 8 | | (OPTION 010) | 28480 | 10544 |
| A15 | 10544-60011 | 3 | 1 | 10 MHZ OVEN OSCILLATOR(OPT. 010) | 28480 | 10544-60011 |
| A15 | 10811-60111 | 8 | 1 | 10MHZ OVEN OSC.(ALT. 10811-60111) | 28480 | 10811-60111 |
| | 10811-90002 | 9 | 1 | OPERATING AND SERVICE MANUAL FOR 10811-60111 | 28480 | 10811-90002 |
| | | | | NOTE | | |
| | | | | The 10544-60011 and 10811-60111 oscillators are directly interchangeable. Instruments with Serial Numbers 2202A02626 or above may have either oscillator assembly. | | |
| | | | | The 10811-60111 oscillator is field serviceable. Repairs may be accomplished by referring to the 10811A/B Operating and Service Manual(10811-90002). This manual is included with every instrument with the 10811-60111 oscillator assembly for A15. | | |
| A16 | | | | NOT ASSIGNED | | |
| A17 | 05335-20203 | 7 | 1 | BOARD-SHIELD (P/O OPT. 040) | 28480 | 05335-20203 |

See introduction to this section for ordering information

*Indicates factory selected value

Reproduced with permission,
Courtesy of Agilent Technologies Inc.

Table 6-3. Replaceable Parts

| Reference Designation | HP Part Number | C D | Qty | Description | Mfr Code | Mfr Part Number |
|--|----------------|-----|-----|---|----------|----------------------|
| MISCELLANEOUS CHASSIS ELECTRICAL PARTS | | | | | | |
| B1 | 3160-0209 | 4 | 1 | FAN-TBAX 32-CFM 105-125V 50/60-HZ | 23936 | 85000 |
| F1 | 2110-0007 | 4 | 1 | FUSE 1A 250V TD 1.25X.25 UL (FOR 100/120V OPERATION) | 75915 | 313001 |
| F1 | 2110-0202 | 1 | 1 | FUSE .5A 250V TD 1.25X.25 UL (FOR 220/240V OPERATION) | 75915 | 313.500 |
| Q1 | 1854-0611 | 1 | 1 | TRANSISTOR NPN 2N6055 SI DARL TO-3 | 04713 | 2N6055 |
| T1 | 9100-4113 | 7 | 1 | TRANSFORMER-AC POWER | 28480 | 9100-4113 |
| W1 | 8120-1378 | 1 | 1 | CABLE ASSY-18AWG 3-COND(AC INPUT) | 28480 | 8120-1378 |
| W2 | 05335-60101 | 8 | 1 | CABLE ASSEMBLY-DC POWER (A1 TO A4) | 28480 | 05335-60101 |
| W3 | 8120-2884 | 6 | 1 | CABLE ASSY-BRAIDED (A4 TO A6) | 28480 | 8120-2884 |
| W4 | 05335-60102 | 9 | 1 | CABLE ASSEMBLY-DISPLAY 15-PIN | 28480 | 05335-60102 |
| W5 | 8120-2867 | 5 | 2 | CABLE ASSY-2.5"LG 18-PIN MALE PLUGS | 28480 | 8120-2867 |
| W6 | 8120-2867 | 5 | | CABLE ASSY-2.5"LG 18-PIN MALE PLUGS | 28480 | 8120-2867 |
| W7 | 05335-60112 | 1 | | CABLE ASSY-COAX 50-OHM (SERIAL PREFIX 2134A AND ABOVE) | 28480 | 05335-60112 |
| W8 | 05335-60112 | 1 | 3 | CABLE ASSY-COAX 50-OHM (SERIAL PREFIX 2134A AND ABOVE) | 28480 | 05335-60112 |
| W9 | 8120-2959 | 6 | 2 | CABLE ASSY-RIBBON 9"LG 16-PIN MALE PLUGS | 28480 | 8120-2959 |
| W10 | 8120-2959 | 6 | | CABLE ASSY-RIBBON 9"LG 16-PIN MALE PLUGS | 28480 | 8120-2959 |
| W11 | 05335-60104 | 1 | 1 | CABLE ASSY-3-WIRE W/SOCKET (FOR Q1) | 28480 | 05335-60104 |
| MISCELLANEOUS CHASSIS HARDWARE PARTS | | | | | | |
| H1 | 2360-0113 | 2 | 9 | SCREW-MACH 6-32 .25-IN-LG PAN-HD-POZI | 00000 | ORDER BY DESCRIPTION |
| H2 | 2336-0190 | 4 | 10 | SCREW-MACH 6-32 X 3/16 IN LG FLAT HD 100 | 28480 | 2336-0190 |
| H3 | 2360-0115 | 4 | 13 | SCREW-MACH 6-32 .312-IN-LG PAN-HD-POZI | 00000 | ORDER BY DESCRIPTION |
| H4 | 2510-0192 | 6 | 16 | SCREW-MACH 8-32 .25-IN-LG 100 DEG | 00000 | ORDER BY DESCRIPTION |
| H5 | 3050-0066 | 8 | 3 | WASHER-FL MTLN NO. 6 .147-IN-ID | 28480 | 3050-0066 |
| H6 | 2680-0128 | 7 | 4 | SCREW-MACH 10-32 .25-IN-LG PAN-HD-POZI | 00000 | ORDER BY DESCRIPTION |
| H7 | 2360-0111 | 0 | 1 | SCREW-MACH 6-32 .188-IN-LG PAN-HD-POZI | 00000 | ORDER BY DESCRIPTION |
| H8 | 2360-0121 | 2 | 4 | SCREW-MACH 6-32 .5-IN-LG PAN-HD-POZI | 00000 | ORDER BY DESCRIPTION |
| H9 | 2420-0001 | 5 | 9 | NUT-HEX-W/LKWR 6-32-THD .109-IN-THK | 00000 | ORDER BY DESCRIPTION |
| H10 | 2950-0035 | 8 | 8 | NUT-HEX-DBL-CHAM 15/32-32-THD | 00000 | ORDER BY DESCRIPTION |
| H11 | 2190-0102 | 8 | 6 | WASHER-LK INTL T 15/32 IN .472-IN-ID | 28480 | 2190-0102 |
| H12 | 2950-0052 | 9 | 2 | NUT-HEX-DBL-CHAM 1/4-40-THD .062-IN-THK | 00000 | ORDER BY DESCRIPTION |
| H13 | 0380-0644 | 4 | 2 | STANDOFF-HEX 9/32 6-32 MALE TO METRIC FE | 00000 | ORDER BY DESCRIPTION |
| H14 | 2190-0034 | 5 | 2 | WASHER-LK HLCL NO. 10 .194-IN-ID | 28480 | 2190-0034 |
| H15 | 0626-0002 | 0 | 2 | SCREW-TPG 6-20 .5-IN-LG PAN-HD-SLT | 00000 | ORDER BY DESCRIPTION |
| H16 | 1200-0043 | 8 | 1 | INSULATOR-XSTR ALUMINUM | 28480 | 1200-0043 |
| H17 | 2510-0135 | 7 | 4 | SCREW-MACH 8-32 2.25-IN-LG PAN-HD-POZI | 00000 | ORDER BY DESCRIPTION |
| H18 | 2580-0003 | 5 | 4 | NUT-HEX-W/LKWR 8-32-THD .125-IN-THK | 00000 | ORDER BY DESCRIPTION |
| H19 | 3050-0001 | 1 | 4 | WASHER-FL MTLN NO. 8 .172-IN-ID | 28480 | 3050-0001 |
| H20 | 2190-0143 | 7 | 4 | WASHER-FL NM NO. 8 .17-IN-ID .438-IN-OD | 28480 | 2190-0143 |
| H21 | 2200-0103 | 2 | 17 | SCREW-MACH 4-40 .25-IN-LG PAN-HD-POZI | 00000 | ORDER BY DESCRIPTION |
| H22 | 3050-0105 | 6 | 3 | WASHER-FL MTLN NO. 4 .125-IN-ID | 28480 | 3050-0105 |
| H23 | 3050-0003 | 3 | 5 | WASHER-FL NM NO. 6 .141-IN-ID .375-IN-OD | 28480 | 3050-0003 |
| H24 | 3050-0124 | 9 | 5 | WASHER-FL MTLN NO. 5 .13-IN-ID | 28480 | 3050-0124 |
| H25 | 0340-0468 | 6 | 5 | INSULATOR-XSTR NYLON | 28480 | 0340-0468 |
| H26 | 0340-0525 | 6 | 5 | INSULATOR-XSTR HARD-ANODIZED-AL | 28480 | 0340-0525 |
| H27 | 0510-1148 | 2 | 15 | CLIP-SPRING RETAINING(FOR A5 CKT BD) | 28480 | 0510-1148 |
| H28 | 1530-1098 | 4 | 5 | CLEVIS 0.070-IN W SLT: 9.454-IN PIN CTR | 00000 | ORDER BY DESCRIPTION |
| H29 | 1400-0482 | 3 | 1 | CABLE TIE .062-3-DIA .14-WD NYL | 28480 | 1400-0482 |
| H30 | 1400-0507 | 3 | 2 | TIE-WRAP PLASTIC 8" LG | 28480 | 1400-0507 |
| H31 | 1400-0531 | 3 | 2 | CLAMP-CABLE PRESS-ON SELF ADHESIVE | 28480 | 1400-0531 |
| H32 | 2950-0072 | 3 | 3 | NUT-HEX-DBL-CHAM 1/4-32-THD .062-IN-THK | 00000 | ORDER BY DESCRIPTION |
| H33 | 1200-0523 | 9 | 2 | LOCK-DUAL INLINE PKG INLINE PKG | 52672 | CA-16-200-DL |
| H34 | 0340-0486 | 8 | 1 | COVER-XSTR INSULATING BLK NYLON | 28480 | 0340-0486 |
| H35 | 0370-1005 | 2 | 3 | KNOR-BASE-PTR 3/8 JGK .125-IN-ID | 28480 | 0370-1005 |
| H36 | 2190-0068 | 5 | 2 | WASHER-LK INTL T 1/2 IN .505-IN-ID | 28480 | 2190-0068 |
| H37 | 0590-0038 | 5 | 2 | NUT-HEX-DBL-CHAM 1/2-32-THD .094-IN-THK | 00000 | ORDER BY DESCRIPTION |
| H38 | 7120-3731 | 3 | 1 | LABEL-WARNING HIGH VOLTAGE (APPLIED ON T1) | 28480 | 7120-3731 |
| H39 | 7120-1254 | 1 | 1 | LOGO-HP FRONT WINDOW(CEMENT-ON) | 28480 | 7120-1254 |

See introduction to this section for ordering information

*Indicates factory selected value

Reproduced with permission,
Courtesy of Agilent Technologies Inc.

Table 6-3. Replaceable Parts (Continued)

| Reference Designation | HP Part Number | C D | Qty | Description | Mfr Code | Mfr Part Number |
|-----------------------|----------------|-----|-----|---|----------|---------------------|
| | | | | MISCELLANEOUS CHASSIS PARTS FOR STD. INSTRUMENT AND OPTIONS 020, 030, 040 | | |
| MP1 | 05335-00001 | 1 | 1 | PANEL-FRONT MAIN (STD.) | 28480 | 05335-00001 |
| MP2 | 05335-00002 | 2 | 2 | PANEL-FRONT BLANK FILLER LESS OPTIONS | 28480 | 05335-00002 |
| MP3 | 05335-00003 | 3 | 1 | PANEL-FRONT SUB | 28480 | 05335-00003 |
| MP4 | 05335-00004 | 4 | 1 | PANEL-REAR (SERIAL PREFIX 2104A & BELOW) | 28480 | 05335-00004 |
| MP4 | 05335-00014 | 6 | 1 | PANEL-REAR (SERIAL PREFIX 2120A & ABOVE) | 28480 | 05335-00014 |
| MP5 | 05335-20201 | 5 | 1 | WINDOW-FRONT PLASTIC RED | 28480 | 05335-20201 |
| MP6 | 5040-6937 | 5 | 3 | RETAINER-SLIDE WINDOW BLACK PLASTIC | 28480 | 5040-6937 |
| MP7 | 5060-9899 | 6 | 2 | HANDLE-FRONT SYSTEM II | 28480 | 5060-9899 |
| MP8 | 5020-8896 | 7 | 2 | HANDLE-FRONT TRIM | 28480 | 5020-8896 |
| MP9 | 2510-0195 | 9 | 6 | SCREW-MACH 8-32 .375-IN-LG 100 DEG | 28480 | 2510-0195 |
| MP10 | 5040-6928 | 4 | 1 | STRIP-DIVIDER FRONT PANEL PLASTIC | 28480 | 5040-6928 |
| MP11 | 5060-9833 | 8 | 1 | COVER-TOP 12-INCH DP | 28480 | 5060-9833 |
| MP12 | 5060-9845 | 2 | 1 | COVER-BOTTOM | 28480 | 5060-9845 |
| MP13 | 5060-9110 | 4 | 1 | COVER-SIDE VENTILATED (LEFT) | 28480 | 5060-9110 |
| MP14 | 5060-9878 | 1 | 1 | COVER-SIDE FOR STRAP HANDLE (RIGHT) | 28480 | 5060-9878 |
| MP15 | 5060-9802 | 1 | 1 | HANDLE-SIDE STRAP | 28480 | 5060-9802 |
| MP16 | 5060-7219 | 0 | 1 | CAP-FRONT HANDLE STRAP | 28480 | 5060-7219 |
| MP17 | 5040-7220 | 1 | 1 | CAP-REAR HANDLE STRAP | 28480 | 5040-7220 |
| MP18 | 2680-0172 | 1 | 2 | SCREW-MACH 10-32 .375-IN-LG 100 DEG | 28480 | 2680-0172 |
| MP19 | 5040-7201 | 8 | 2 | FOOT-CABINET FRONT | 28480 | 5040-7201 |
| MP20 | 1460-1345 | 5 | 2 | STAND-TILT SS STL | 28480 | 1460-1345 |
| MP21 | 5040-7222 | 3 | 2 | FOOT-CABINET REAR NON-SKID | 28480 | 5040-7222 |
| MP22 | 3160-0309 | 5 | 1 | GRILL-FAN | 4N833 | 12601-43 UL VERSION |
| MP23 | 5040-7202 | 9 | 1 | TRIM-CABINET TOP-FRONT INSERT PLASTIC | 28480 | 5040-7202 |
| MP24 | 05335-00015 | 7 | 2 | BRKT-SUPPORT FLAT/THD INSERT (TOP FRONT) | 28480 | 05335-00015 |
| MP25 | 05335-00009 | 9 | 1 | SHIELD-INSULATOR SAFETY COVER | 28480 | 05335-00009 |
| MP26 | 05335-40001 | 5 | 2 | CROSS BRACE CHASSIS-CKT-BD-MTG MOLDED | 28480 | 05335-40001 |
| MP27 | 05335-00010 | 2 | 1 | BRACKET-SUPPORT HP-IB ASSY A7 | 28480 | 05335-00010 |
| MP28 | 0460-8832 | 2 | 2 | PAD-VINYL SELF ADHESIVE 7.25 IN LG | 76381 | SJ-5510 |
| MP29 | 5020-8803 | 6 | 1 | FRAME-CHASSIS FRONT | 28480 | 5020-8803 |
| MP30 | 5020-8804 | 7 | 1 | FRAME-CHASSIS REAR | 28480 | 5020-8804 |
| MP31 | 5020-8835 | 4 | 4 | FRAME-CORNER STRUT | 28480 | 5020-8835 |
| MP32 | 7120-8385 | 3 | 1 | LABEL-OPERATION TOP COVER | 28480 | 7120-8385 |
| MP33 | 05335-00013 | 5 | 1 | PANEL-FRONT OPT. 040 | 28480 | 05335-00013 |
| MP34 | 05335-00007 | 7 | 1 | PANEL-FRONT INSERT OPT. 020 (DVM) | 28480 | 05335-00007 |
| MP35 | 05335-00008 | 8 | 1 | PANEL-FRONT INSERT OPT. 030 ("C" CHANNEL) | 28480 | 05335-00008 |

See introduction to this section for ordering information
*Indicates factory selected value

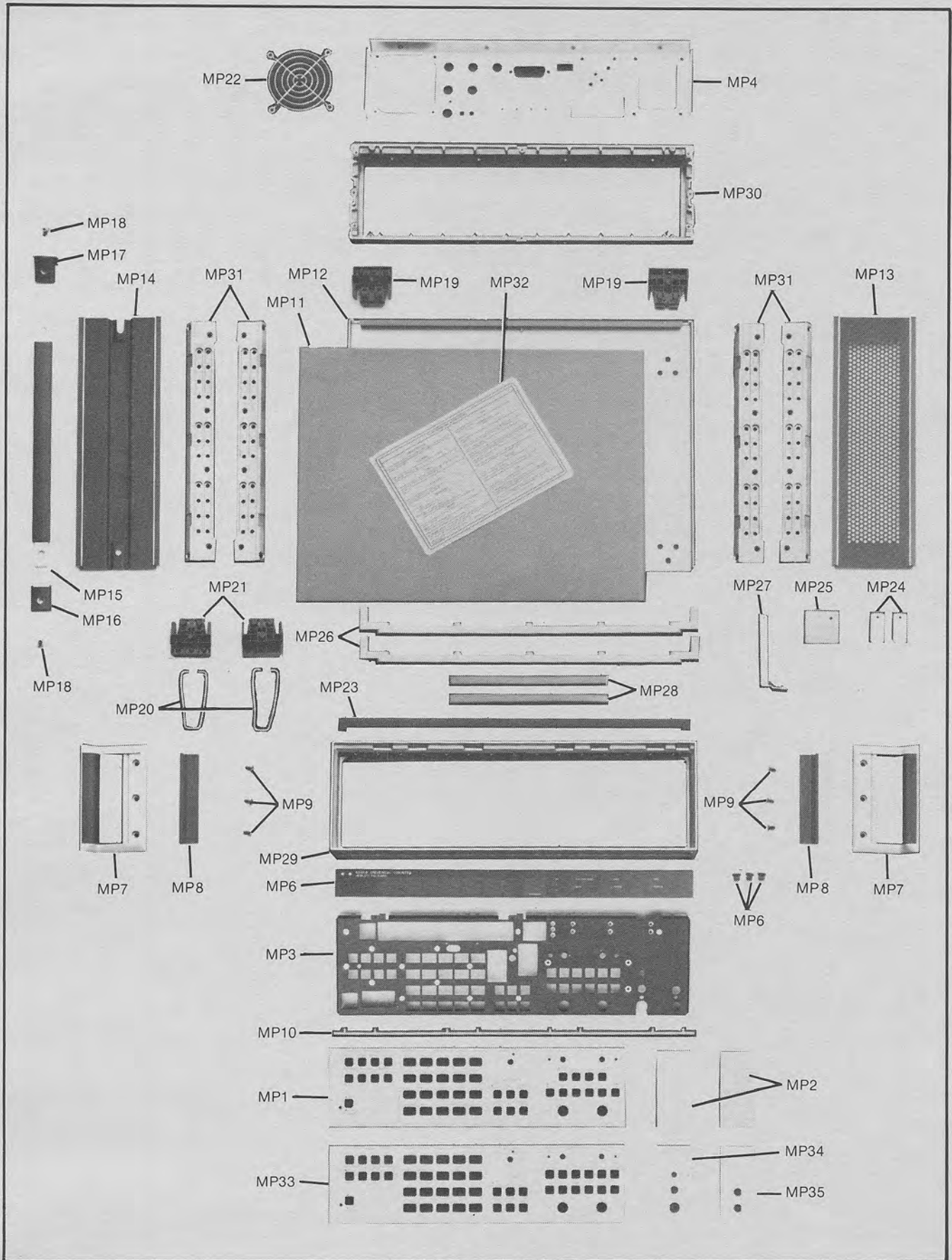
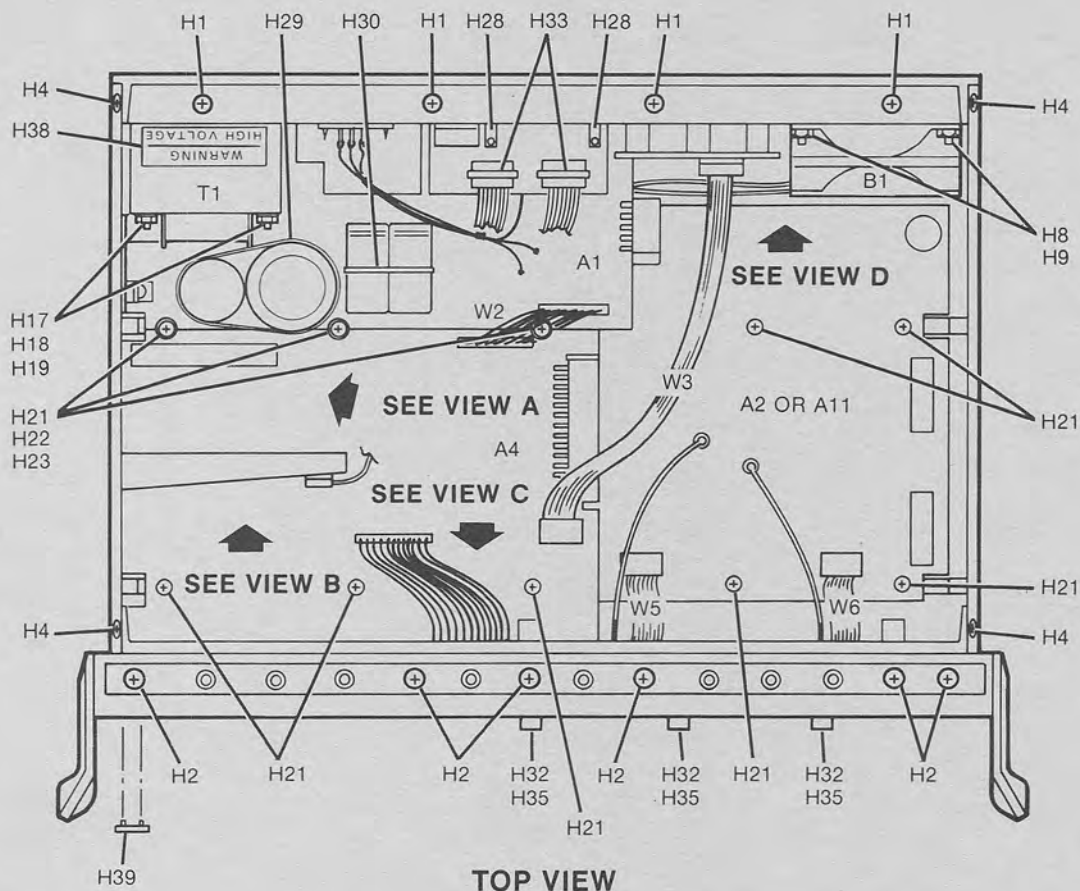

Figure 6-1. Cabinet Parts



TOP VIEW

| REFERENCE DESIGNATION | HP PART NUMBER | C D | DESCRIPTION |
|-----------------------|----------------|--------|---|
| H1 | 2360-0113 | 2 | SCREW-MACH 6-32 × .250-IN-LG PAN-HD POZI/LOCK |
| H2 | 2360-0190 | 4 | SCREW-MACH 6-32 × 3/16-IN-LG FLAT HD 100-DEG POZI |
| H4 | 2510-0192 | 6 | SCREW-MACH 8-32 × .250-IN-LG FLAT-HD 100-DEG POZI |
| H8 | 2360-0121 | 2 | SCREW-MACH 6-32 × .50-IN-LG PAN-HD POZI/LOCK |
| H9 | 2420-0001 | 5 | NUT-HEX 6-32 × 5/16-IN WITH LOCK |
| H17 | 2510-0135 | 7 | SCREW-MACH 8-32 × 2.25-IN-LOG PAN-HD POZI |
| H18 | 2580-0003 | 5 | NUT-HEX 8-32 × 11/32 WITH LOCK |
| H19 | 3050-0001 | 1 | WASHER-FLAT NO. 8 METALIC .172-IN-ID |
| H21 | 2200-0103 | 2 | SCREW-MACH 4-40 × .250-IN PAD-HD POZI/LOCK |
| H22 | 3050-0105 | 6 | WASHER-FLAT NO. 4 METALIC .125-IN-ID |
| H23 | 3050-0003 | 3 | WASHER-FLAT NO. 6 FIBER .375-IN-OD |
| H28 | 1530-1098 | 4 | CLEVIS-MOUNTING CIRCUIT BOARD |
| H29 | 1400-0482 | 3 | TIE-WRAP PLASTIC 11-IN-LG |
| H30 | 1400-0507 | 3 | TIE-WRAP PLASTIC 8-IN-LG |
| H32 | 2950-0072 | 3 | NUT-HEX 1/4-32 × 5/16-IN |
| H33 | 1200-0523 | 9 | LOCK-PLUG DUAL-INLINE 16-PIN |
| H35 | 0370-1005 | 2 | KNOB-BASE-PTR 3/8JGK .125-IN-ID |
| H38 | 7120-3731 | 3 | LABEL-WARNING HIGH VOLTAGE (APPLIED ON T1) |
| H39 | 7120-1254 | 1 | LOGO-HP FRONT WINDOW (CEMENT-ON) |

Figure 6-2. Top View Parts

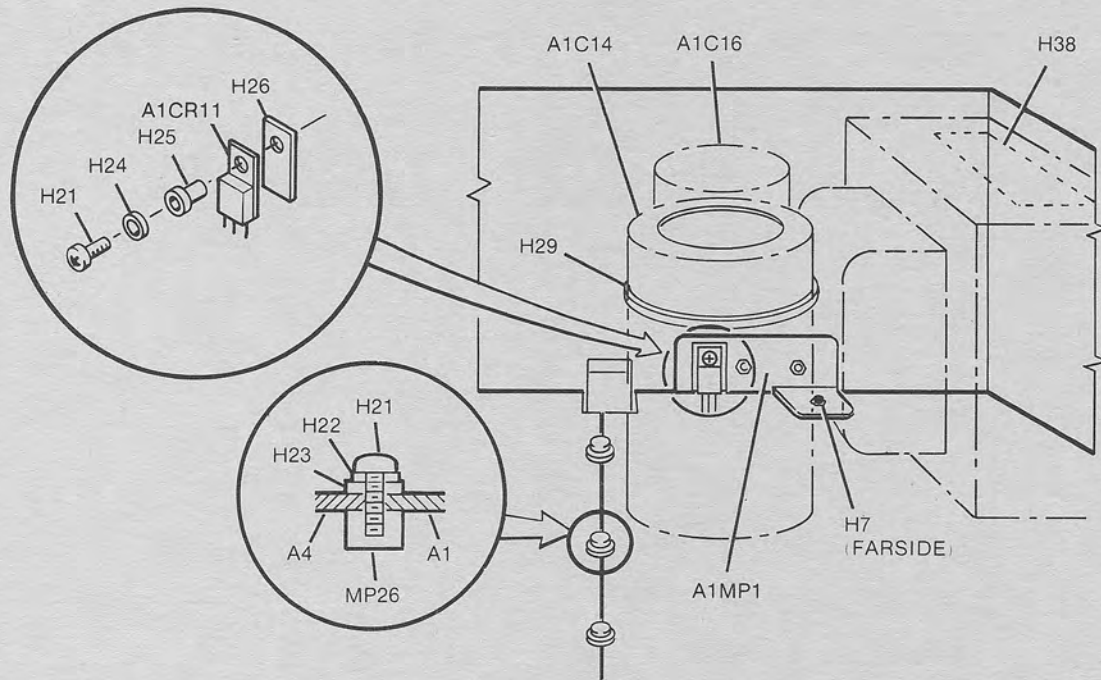

VIEW A OF TOP VIEW

| REFERENCE DESIGNATION | HP PART NUMBER | C D | DESCRIPTION |
|-----------------------|----------------|--------|---|
| H7 | 2360-0111 | 0 | SCREW-MACH 6-32 × 3/16-IN-LG PAN-HD POZI/LOCK |
| H21 | 2200-0103 | 2 | SCREW-MACH 4-40 × .250-IN PAN-HD POZI/LOCK |
| H22 | 3050-0105 | 6 | WASHER-FLAT NO. 4 METALIC .125-IN-ID |
| H23 | 3050-0003 | 3 | WASHER-FLAT NO. 6 FIBER .375-IN-OD |
| H24 | 3050-0124 | 9 | WASHER-FLAT NO. 4 METALIC |
| H25 | 0340-0468 | 6 | WASHER-EXTRUDED XSTR-INSULATOR NYLON |
| H26 | 0340-0525 | 6 | INSULATOR-XSTR HARD-ANODIZED-AL |
| H29 | 1400-0482 | 3 | TIE-WRAP PLASTIC 11-IN-LG |
| H38 | 7120-3731 | 3 | LABEL-WARNING HIGH VOLTAGE (APPLIED ON T1) |

Figure 6-3. View A Parts

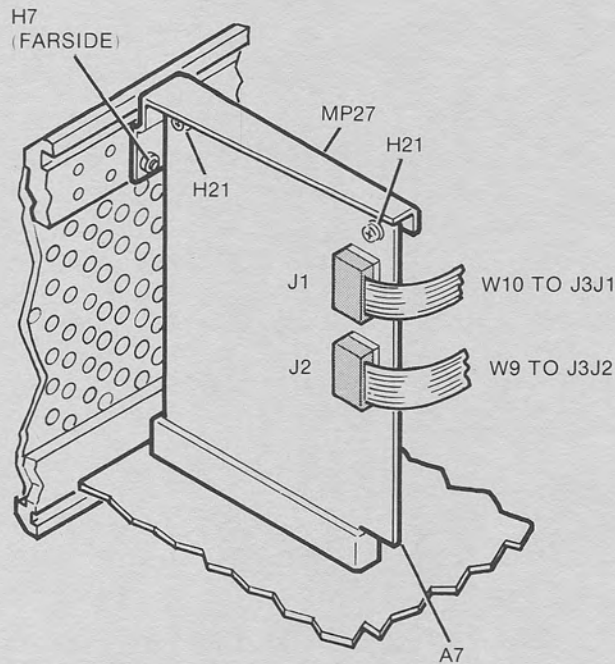

VIEW B OF TOP VIEW

| REFERENCE DESIGNATION | HP PART NUMBER | C D | DESCRIPTION |
|-----------------------|----------------|--------|---|
| H7 | 2360-0111 | 0 | SCREW-MACH 6-32 × 3/16-IN-LG PAN-HD POZI/LOCK |
| H21 | 2200-0103 | 2 | SCREW-MACH 4-40 × .250-IN PAN-HD POZI/LK |

Figure 6-4. View B Parts

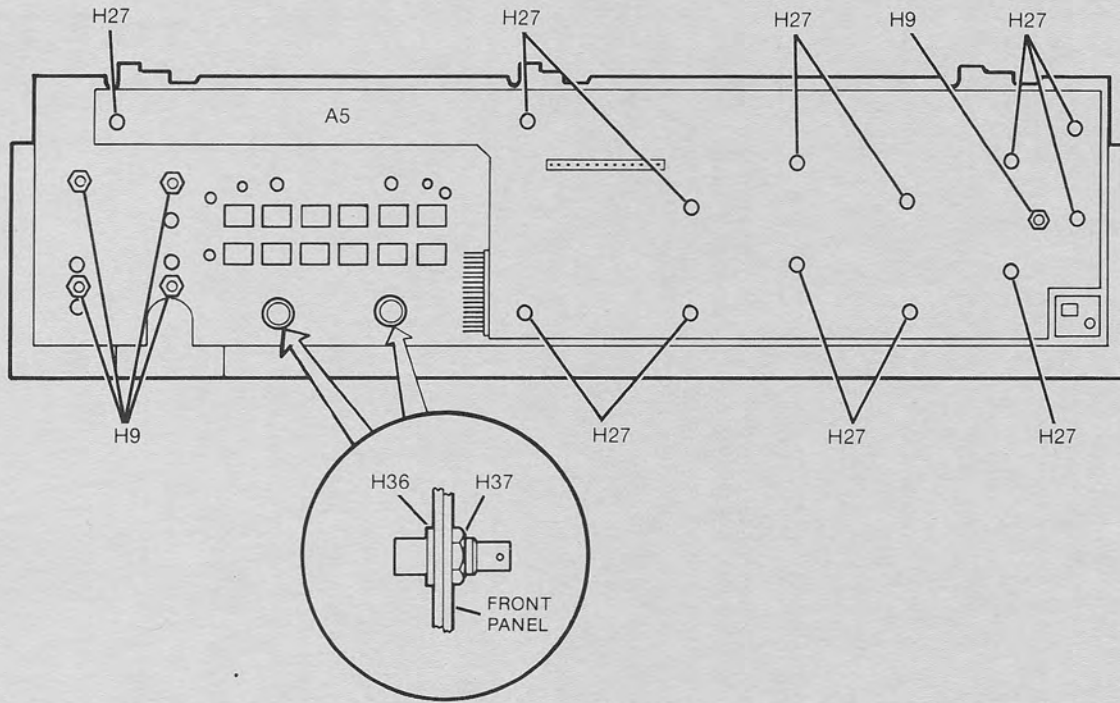

VIEW C OF TOP VIEW

| REFERENCE DESIGNATION | HP PART NUMBER | C D | DESCRIPTION |
|-----------------------|----------------|--------|--|
| H9 | 2420-0001 | 5 | NUT-HEX 6-32 × 5/16-IN WITH LOCK |
| H27 | 0510-1148 | 2 | CLIP-SPRING RETAINING (FOR A5 CLT BD) |
| H36 | 2190-0068 | 9 | WASHER-LOCK .50-IN-ID (BEHIND FRONT PANEL BNC) |
| H37 | 0590-0382 | 5 | NUT-HEX 1/2-32 × 9/16-IN (FRONT-PANEL BNC) |

Figure 6-5. View C Parts

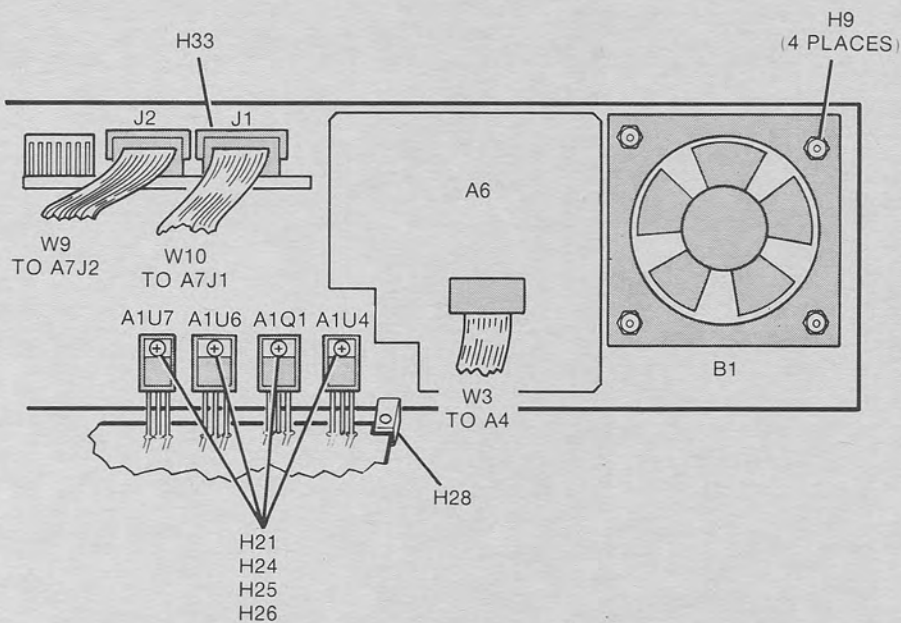

VIEW D OF TOP VIEW

| REFERENCE DESIGNATION | HP PART NUMBER | C D | DESCRIPTION |
|-----------------------|----------------|--------|--|
| H9 | 2420-0001 | 5 | NUT-HEX 6-32 × 5/16-IN WITH LOCK |
| H21 | 2200-0103 | 2 | SCREW-MACH 4-40 × .250-IN PAD-HD POZI/LOCK |
| H24 | 3050-0124 | 9 | WASHER-FLAT NO. 4 METALIC |
| H25 | 0340-0468 | 6 | WASHER-EXTRUDED XSTR-INSTULATOR NYLON |
| H26 | 0340-0525 | 6 | INSULATOR-XSTR HARD-ANODIZED-AL |
| H28 | 1530-1098 | 4 | CLEVIS-MOUNTING CIRCUIT BOARD |
| H33 | 1200-0523 | 9 | LOCK-PLUG DUAL-INLINE 16-PIN |

Figure 6-6. View D Parts

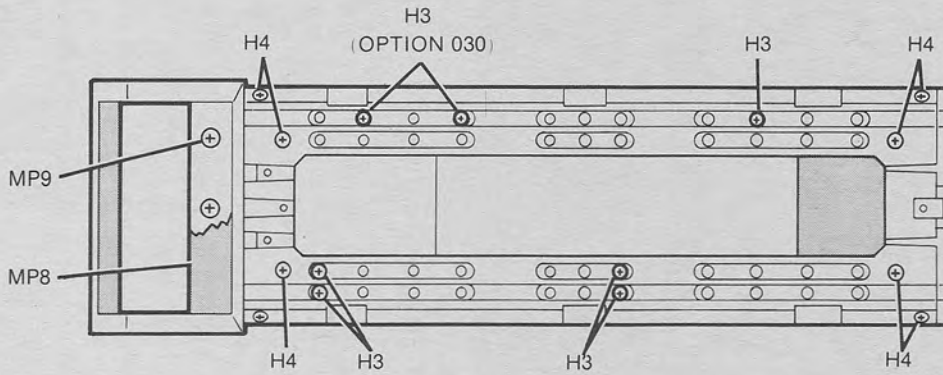

RIGHT SIDE WITH STRAP HANDLE & SIDE COVER REMOVED

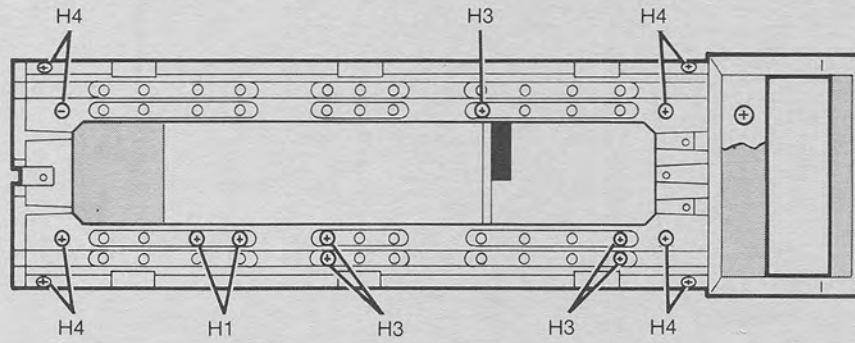

LEFT SIDE WITH VENTILATED COVER REMOVED

| REFERENCE DESIGNATION | HP PART NUMBER | C D | DESCRIPTION |
|-----------------------|----------------|--------|---|
| H1 | 2360-0113 | 2 | SCREW-MACH 6-32 × .250-IN-LG PAN-HD POZI/LOCK |
| H3 | 2360-0115 | 4 | SCREW-MACH 6-32 × 5/16-IN-LG PAN-HD POZI-LOCK |
| H4 | 2510-0192 | 6 | SCREW-MACH 8-32 × .250-IN-LG FLAT-HD 100-DEG POZI |

Figure 6-7. Side View Parts

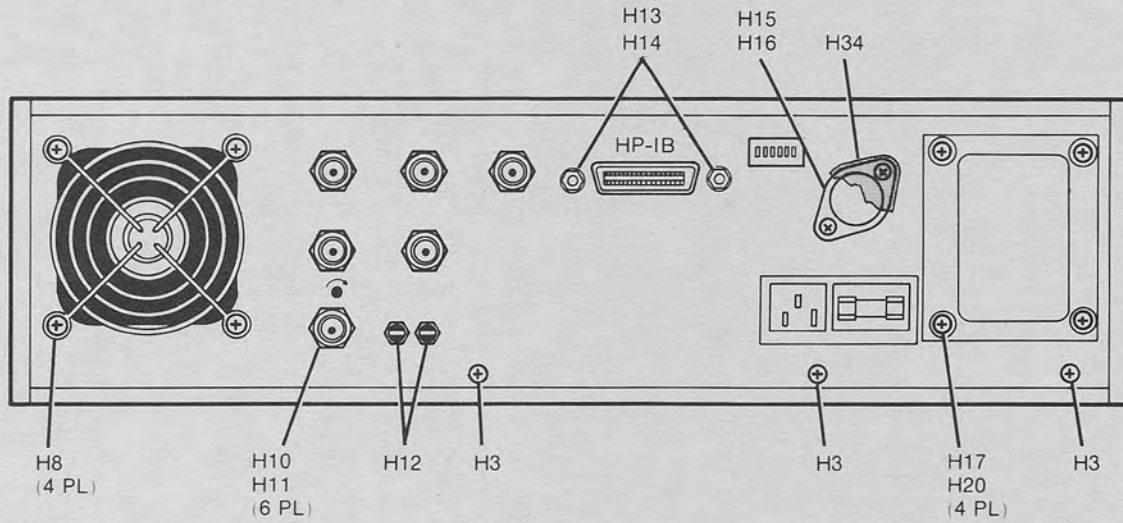

REAR PANEL

| REFERENCE DESIGNATION | HP PART NUMBER | C D | DESCRIPTION |
|-----------------------|----------------|--------|--|
| H3 | 2360-0115 | 4 | SCREW-MACH 6-32 × 5/16-IN-LG PAN-HD POZI/LOCK |
| H8 | 2360-0121 | 2 | SCREW-MACH 6-32× .50-IN-LG PAN-HD POZI/LOCK |
| H10 | 2950-0035 | 8 | NUT-HEX 15/32-32 × 9/16-IN |
| H11 | 2190-0102 | 8 | WASHER-LOCK INTERNAL TOOTH 15/32-IN-ID |
| H12 | 2950-0052 | 9 | NUT-HEX 1/4-40 × 5/16-IN |
| H13 | 0380-0644 | 4 | STANDOFF-HEX 9/32 × 6-32 MALE-TO-METRIC FEMALE |
| H14 | 2190-0034 | 5 | WASHER-SPLIT LOCK NO. 10 .194-IN-ID |
| H15 | 0626-0002 | 0 | SCREW-SELF TAPPING 6-20 × .50-IN-LG |
| H16 | 1200-0043 | 8 | INSTULATOR-XSTR HARD-ANODIZED-AL (FOR Q1) |
| H17 | 2510-0135 | 7 | SCREW-MACH 8-32 × 2.25-IN-LOG PAN-HD POZI |
| H20 | 2190-0143 | 7 | WASHER-FLAT NO. 8 FIBER .172-IN-ID |
| H34 | 0340-0486 | 8 | COVER-XSTR INSULATING BLOCK-NYLON |

Figure 6-8. Rear Panel Parts

Table 6-4. Option 020 DVM Replaceable Parts

| Reference Designation | HP Part Number | C D | Qty | Description | Mfr Code | Mfr Part Number |
|-----------------------|----------------|-----|-----|--|----------|------------------|
| AB | 05335-60008 | 4 | 1 | (OPTION 020) BOARD ASSEMBLY-DVM (SERIES 1928) | 28480 | 05335-60008 |
| ABC1 | 0180-2730 | 9 | 2 | CAPACITOR-FXD 1700UF+75-10% 30VDC AL | 28480 | 0180-2730 |
| ABC2 | 0180-2730 | 9 | | CAPACITOR-FXD 1700UF+75-10% 30VDC AL | 28480 | 0180-2730 |
| ABC3 | 0160-0576 | 5 | 4 | CAPACITOR-FXD .1UF +-20% 50VDC CER | 28480 | 0160-0576 |
| ABC4 | 0160-0576 | 5 | | CAPACITOR-FXD .1UF +-20% 50VDC CER | 28480 | 0160-0576 |
| ABC5 | 0160-4557 | 0 | 1 | CAPACITOR-FXD .1UF +-20% 50VDC CER | 16299 | CAC04X7R104M050A |
| ABC6 | 0180-2821 | 9 | 2 | CAPACITOR-FXD 22UF+-20% 35VDC TA | 28480 | 0180-2821 |
| ABC7 | 0180-2821 | 9 | | CAPACITOR-FXD 22UF+-20% 35VDC TA | 28480 | 0180-2821 |
| ABC8 | 0160-0300 | 3 | 1 | CAPACITOR-FXD 2700PF +-10% 200VDC POLYE | 28480 | 0160-0300 |
| ABC10 | 0160-0576 | 5 | | CAPACITOR-FXD .1UF +-20% 50VDC CER | 28480 | 0160-0576 |
| ABC11 | 0160-0576 | 5 | | CAPACITOR-FXD .1UF +-20% 50VDC CER | 28480 | 0160-0576 |
| ABC12 | 0160-4554 | 7 | 5 | CAPACITOR-FXD .01UF +-20% 50VDC CER | 28480 | 0160-4554 |
| ABC13 | 0160-4554 | 7 | | CAPACITOR-FXD .01UF +-20% 50VDC CER | 28480 | 0160-4554 |
| ABC14 | 0160-4554 | 7 | | CAPACITOR-FXD .01UF +-20% 50VDC CER | 28480 | 0160-4554 |
| ABC15 | 0160-4554 | 7 | | CAPACITOR-FXD .01UF +-20% 50VDC CER | 28480 | 0160-4554 |
| ABC16 | 0160-4554 | 7 | | CAPACITOR-FXD .01UF +-20% 50VDC CER | 28480 | 0160-4554 |
| ABC17 | 0160-4801 | 7 | 1 | CAPACITOR-FXD 100PF +-5% 100VDC CER | 28480 | 0160-4801 |
| ABC18 | 0160-0314 | 9 | 1 | CAPACITOR-FXD .01UF +-5% 400VDC POLYE | 84411 | 6630W10354W2 |
| ABCR1 | 1906-0069 | 4 | 1 | DIODE-FW BRDG 400V 1A | 28480 | 1906-0069 |
| ABCR2 | 1901-0033 | 2 | 1 | DIODE-GEN PRP 180V 200MA D0-7 | 28480 | 1901-0033 |
| ABCR3 | 1901-0050 | 3 | 2 | DIODE-SWITCHING 80V 200MA 2NS D0-35 | 28480 | 1901-0050 |
| ABCR4 | 1901-0050 | 3 | | DIODE-SWITCHING 80V 200MA 2NS D0-35 | 28480 | 1901-0050 |
| ABH30 | 1400-0507 | 3 | 1 | TIE WRAP 8" LG PLASTIC | 28480 | 1400-0507 |
| ABQ1 | | | | NOT ASSIGNED | | |
| ABQ2 | 1854-0215 | 1 | 1 | TRANSISTOR NPN SI PD=350MW FT=300MHZ | 04713 | 2N3904 |
| ABQ3 | 1853-0036 | 2 | 2 | TRANSISTOR PNP SI PD=310MW FT=250MHZ | 28480 | 1853-0036 |
| ABQ4 | 1855-0368 | 7 | 3 | TRANSISTOR J-FET N-CHAN D-MODE T0-72 SI | 28480 | 1855-0368 |
| ABQ5 | 1855-0368 | 7 | | TRANSISTOR J-FET N-CHAN D-MODE T0-72 SI | 28480 | 1855-0368 |
| ABQ6 | 1855-0368 | 7 | | TRANSISTOR J-FET N-CHAN D-MODE T0-72 SI | 28480 | 1855-0368 |
| ABQ7 | 1853-0036 | 2 | | TRANSISTOR PNP SI PD=310MW FT=250MHZ | 28480 | 1853-0036 |
| ABR1 | 0757-0428 | 1 | 1 | RESISTOR 1.62K 1% .125W F TC=0+-100 | 24546 | C4-1/8-T0-1621-F |
| ABR2 | 2100-3094 | 4 | 3 | RESISTOR-TRMR 100K 10% C SIDE-ADJ 17-TRN | 02111 | 43P104 |
| ABR3 | 0757-0286 | 9 | 1 | RESISTOR 100 1% .125W F TC=0+-25 | 19701 | MF4C1/D-T9-131-F |
| ABR4 | 0698-6964 | 6 | 3 | RESISTOR 49.5K .1% .125W F TC=0+-25 | 28480 | 0698-6964 |
| ABR5 | | | | NOT ASSIGNED | | |
| ABR6 | 0698-0082 | 7 | 1 | RESISTOR 464 1% .125W F TC=0+-100 | 24546 | C4-1/8-T0-4640-F |
| ABR7 | 0698-3155 | 1 | 1 | RESISTOR 4.64K 1% .125W F TC=0+-100 | 24546 | C4-1/8-T0-4641-F |
| ABR8 | 0698-4008 | 5 | 1 | RESISTOR 40K 1% .125W F TC=0+-100 | 24546 | C4-1/8-T0-4002-F |
| ABR9 | 0698-3162 | 0 | 5 | RESISTOR 46.4K 1% .125W F TC=0+-100 | 24546 | C4-1/8-T0-4642-F |
| ABR10 | 2100-3154 | 7 | 1 | RESISTOR-TRMR 1K 10% C SIDE-ADJ 17-TRN | 02111 | 43P102 |
| ABR11 | 0698-6964 | 6 | | RESISTOR 49.5K .1% .125W F TC=0+-25 | 28480 | 0698-6964 |
| ABR12 | 0698-3162 | 0 | | RESISTOR 46.4K 1% .125W F TC=0+-100 | 24546 | C4-1/8-T0-4642-F |
| ABR13 | 0698-6606 | 3 | 1 | RESISTOR 495K 1% .125W F TC=0+-25 | 28480 | 0698-6606 |
| ABR14 | 0698-3162 | 0 | | RESISTOR 46.4K 1% .125W F TC=0+-100 | 24546 | C4-1/8-T0-4642-F |
| ABR15 | 2100-3103 | 6 | 1 | RESISTOR-TRMR 10K 10% C SIDE-ADJ 17-TRN | 02111 | 43P103 |
| ABR16 | 0757-0442 | 9 | 6 | RESISTOR 10K 1% .125W F TC=0+-100 | 24546 | C4-1/8-T0-1002-F |
| ABR17 | 0757-0442 | 9 | | RESISTOR 10K 1% .125W F TC=0+-100 | 24546 | C4-1/8-T0-1002-F |
| ABR18 | 0757-0465 | 6 | 1 | RESISTOR 100K 1% .125W F TC=0+-100 | 24546 | C4-1/8-T0-1003-F |
| ABR19 | 2100-3094 | 4 | | RESISTOR-TRMR 100K 10% C SIDE-ADJ 17-TRN | 02111 | 43P104 |
| ABR20 | 0757-0442 | 9 | | RESISTOR 10K 1% .125W F TC=0+-100 | 24546 | C4-1/8-T0-1002-F |
| ABR21 | 0698-7959 | 1 | 1 | RESISTOR 4.95M 1% 1W F TC=0+-25 | 28480 | 0698-7959 |
| ABR22 | 0698-3162 | 0 | | RESISTOR 46.4K 1% .125W F TC=0+-100 | 24546 | C4-1/8-T0-4642-F |
| ABR23 | 1810-0374 | 1 | 1 | NETWORK-RES 8-SIP1.0K DNM X 4 | 01121 | 2888102 |
| ABR24 | 0757-0442 | 9 | | RESISTOR 10K 1% .125W F TC=0+-100 | 24546 | C4-1/8-T0-1002-F |
| ABR25 | 0757-0442 | 9 | | RESISTOR 10K 1% .125W F TC=0+-100 | 24546 | C4-1/8-T0-1002-F |
| ABR26 | 0698-6367 | 3 | 1 | RESISTOR 22.22 .1% .125W F TC=0+-25 | 28480 | 0698-6367 |
| ABR27 | 0698-6964 | 6 | | RESISTOR 49.5K .1% .125W F TC=0+-25 | 28480 | 0698-6964 |
| ABR28 | 0698-3931 | 1 | 1 | RESISTOR 2M .1% .125W F TC=0+-25 | 28480 | 0698-3931 |
| ABR29 | 0757-0442 | 9 | | RESISTOR 10K 1% .125W F TC=0+-100 | 24546 | C4-1/8-T0-1002-F |
| ABR30 | 2100-3094 | 4 | | RESISTOR-TRMR 100K 10% C SIDE-ADJ 17-TRN | 02111 | 43P104 |
| ABR31 | 0698-3162 | 0 | | RESISTOR 46.4K 1% .125W F TC=0+-100 | 24546 | C4-1/8-T0-4642-F |
| ABR32 | 0698-3964 | 0 | 1 | RESISTOR 8M .5% .25W F TC=0+-25 | 03088 | PHE64798M.5Z |
| ABT1 | 9100-0439 | 2 | 1 | TRANSFORMER-ISOLATION 35.4V +-13.7% | 28480 | 9100-0439 |
| ABTP1-ABTP4 | 0360-1682 | 0 | 4 | TERMINAL-STUD SGL-TUR PRESS-MTG | 28480 | 0360-1682 |
| ABU1 | 1826-0625 | 8 | 1 | IC-V RGLTR | 28480 | 1826-0625 |
| ABU2 | 1990-0429 | 7 | 1 | OPTO-ISOLATOR LED-IC GATE IF=10MA-MAX | 28480 | 1990-0429 |
| ABU3 | 1820-1195 | 7 | 1 | IC FF TTL LS D-TYPE POS-EDGE-TRIG COM | 01295 | SN74LS175N |
| ABU4 | 1826-0650 | 9 | 1 | IC-V RGLTR-V-REF-ADJ 2.5/10V | 28480 | 1826-0650 |
| ABU5 | 1826-0635 | 0 | 2 | IC OP AMP LOW-DFS 8-DIP-P PKG | 06665 | OP-07CP |

See introduction to this section for ordering information

*Indicates factory selected value.

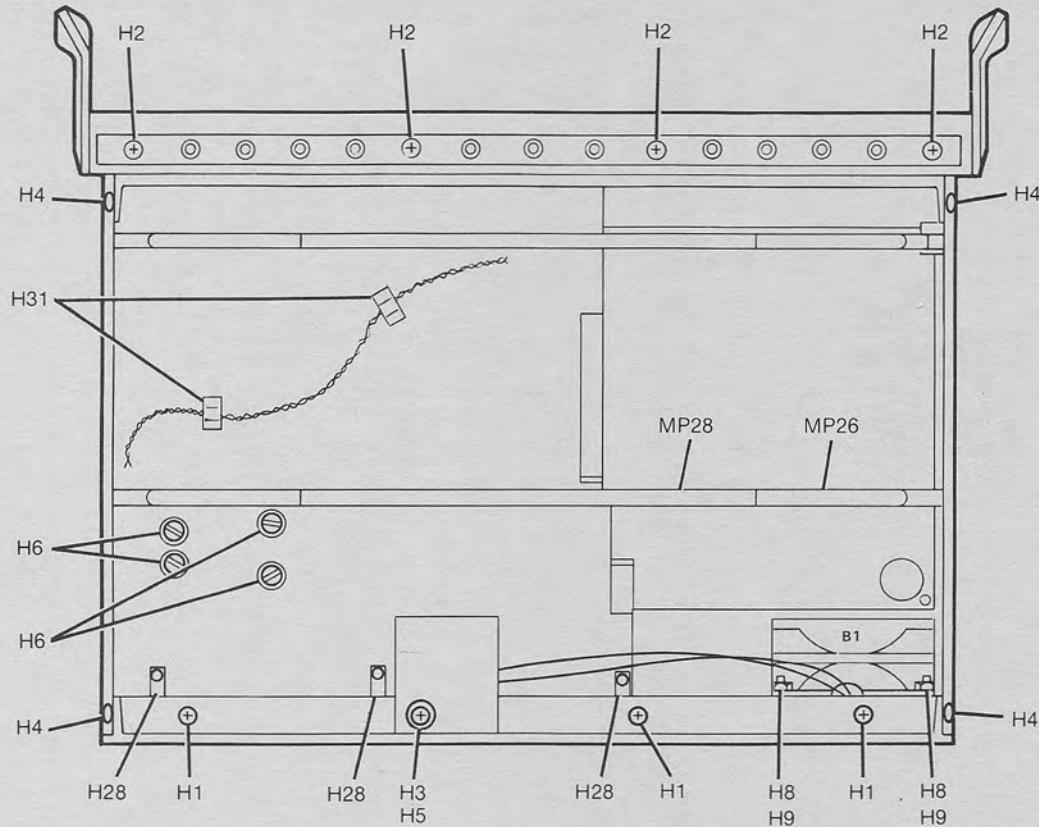

BOTTOM VIEW

| REFERENCE DESIGNATION | HP PART NUMBER | C D | DESCRIPTION |
|-----------------------|----------------|--------|---|
| H1 | 2360-0113 | 2 | SCREW-MACH 6-32 × .250-IN-LG PAN-HD POZI/LOCK |
| H2 | 2360-0190 | 4 | SCREW-MACH 6-32 × 3/16-IN-LG FLAT HD 100-DEG POZI |
| H3 | 2360-0115 | 4 | SCREW-MACH 6-32 × 5/16-IN-LG PAN-HD POZI/LOCK |
| H4 | 2510-0192 | 6 | SCREW-MACH 8-32 × .250-IN-LG FLAT-HD 100-DEG POZI |
| H5 | 3050-0066 | 8 | WASHER-FLAT NO. 6 METALIC .375-IN-OD |
| H6 | 2680-0128 | 7 | SCREW-MACH 10-32 × .250-IN-LOG PAN-HD POZI/LOCK |
| H8 | 2360-0121 | 2 | SCREW-MACH 6-32 × .50-IN-LG PAN-HD POZI/LOCK |
| H9 | 2420-0001 | 5 | NUT-HEX 6-32 × 5/16-IN WITH LOCK |
| H28 | 1530-1098 | 4 | CLEVIS-MOUNTING CIRCUIT BOARD |
| H31 | 1400-0531 | 3 | CLAMP-CABLE PRESS-ON SELF ADHESIVE |

Figure 6-9. Bottom View Parts

Table 6-4. Option 020 DVM Replaceable Parts (Continued)

| Reference Designation | HP Part Number | C D | Qty | Description | Mfr Code | Mfr Part Number |
|-----------------------|----------------|--------|-----|---|----------|------------------|
| A8U6 | 1826-0624 | 7 | 1 | IC CONV V/FREQ 14-DIP-P PKG | 8E175 | VFC32KP |
| A8U7 | 1826-0610 | 1 | 1 | IC MULTIPLXR 4-CHAN-ANLG DUAL 16-DIP-C | 06665 | MUX24FQ |
| A8U8 | 1826-0635 | 0 | | IC OP AMP LOW-OFS 8-DIP-P PKG | 06665 | OP-07CP |
| A8U9 | 1990-0543 | 6 | 4 | OPTO-ISOLATOR LED-PXSTR IF=150MA-MAX | 01295 | TIL116 |
| A8U10 | 1990-0543 | 6 | | OPTO-ISOLATOR LED-PXSTR IF=150MA-MAX | 01295 | TIL116 |
| A8U11 | 1826-0627 | 0 | 1 | IC OP AMP PRCN T0-99 PKG | 24355 | AD542L |
| A8U12 | 1990-0543 | 6 | | OPTO-ISOLATOR LED-PXSTR IF=150MA-MAX | 01295 | TIL116 |
| A8U13 | 1990-0543 | 6 | | OPTO-ISOLATOR LED-PXSTR IF=150MA-MAX | 01295 | TIL116 |
| | | | | A8 MISCELLANEOUS PARTS | | |
| | 0340-0060 | 4 | 2 | TERMINAL-STUD SPCL-FDTHRU PRESS-MTG | 98291 | 011-6809 000 209 |
| | 0360-0124 | 3 | 2 | CONNECTOR-SGL CONT PIN .04-IN-BSC-SZ RND | 28480 | 0360-0124 |
| | 0380-0310 | 1 | 2 | STANDOFF-RVT-ON .75-IN-LG 6-32THD | 28480 | 0380-0310 |
| | 0380-0311 | 2 | 1 | STANDOFF-RVT-ON .5-IN-LG 6-32THD | 28480 | 0380-0311 |
| | 05335-00011 | 3 | 1 | SHIELD-DVM | 28480 | 05335-00011 |
| | | | | OPT. 020 REQUIRES THE FOLLOWING PARTS THAT ARE NOT PART OF CKT BD. A8. | | |
| A8W1 | 05335-60111 | 9 | 1 | CABLE ASSEMBLY-DVM POS/BP | 28480 | 05335-60111 |
| A8W2 | 05335-60110 | 0 | 1 | CABLE ASSEMBLY-DVM NEG/BP | 28480 | 05335-60110 |
| A8H1 | 2950-0144 | 0 | 2 | NUT-HEX 3/8-32 X 13MM PLASTIC | 28480 | 2950-0144 |
| A8MP35 | 05335-00007 | 7 | 1 | PANEL-FRONT DVM | 28480 | 05335-00007 |

See introduction to this section for ordering information
*Indicates factory selected value

Table 6-5. Option 030 "C" Channel Replaceable Parts

| Reference Designation | HP Part Number | C D | Qty | Description | Mfr Code | Mfr Part Number |
|-----------------------|----------------|-----|-----|--|----------|------------------|
| A9 | 05335-60009 | 5 | 1 | BOARD ASSEMBLY-CHANNEL C (SERIES 2121) | 28480 | 05335-60009 |
| A9C1 | 0160-0576 | 5 | 17 | CAPACITOR-FXD .1UF +-20% 50VDC CER | 28480 | 0160-0576 |
| A9C2 | 0180-2617 | 1 | 5 | CAPACITOR-FXD 6.8UF+-10% 35VDC TA | 25088 | D6R8GS1B35K |
| A9C3 | 0160-0576 | 5 | | CAPACITOR-FXD .1UF +-20% 50VDC CER | 28480 | 0160-0576 |
| A9C4 | 0180-2617 | 1 | | CAPACITOR-FXD 6.8UF+-10% 35VDC TA | 25088 | D6R8GS1B35K |
| A9C5 | 0160-0576 | 5 | | CAPACITOR-FXD .1UF +-20% 50VDC CER | 28480 | 0160-0576 |
| A9C6 | 0160-3878 | 6 | 3 | CAPACITOR-FXD 1000PF +-20% 100VDC CER | 28480 | 0160-3878 |
| A9C7 | 0160-0576 | 5 | | CAPACITOR-FXD .1UF +-20% 50VDC CER | 28480 | 0160-0576 |
| A9C8 | 0160-3878 | 6 | | CAPACITOR-FXD 1000PF +-20% 100VDC CER | 28480 | 0160-3878 |
| A9C9 | 05335-80004 | 2 | 1 | COIL-CAPACITOR ASSEMBLY | 28480 | 05335-80004 |
| A9C10 | 0160-0576 | 5 | | CAPACITOR-FXD .1UF +-20% 50VDC CER | 28480 | 0160-0576 |
| A9C11 | 0160-0576 | 5 | | CAPACITOR-FXD .1UF +-20% 50VDC CER | 28480 | 0160-0576 |
| A9C12 | 0180-2617 | 1 | | CAPACITOR-FXD 6.8UF+-10% 35VDC TA | 25088 | D6R8GS1B35K |
| A9C13 | 0160-0576 | 5 | | CAPACITOR-FXD .1UF +-20% 50VDC CER | 28480 | 0160-0576 |
| A9C14 | 0160-0576 | 5 | | CAPACITOR-FXD .1UF +-20% 50VDC CER | 28480 | 0160-0576 |
| A9C15 | 0160-0576 | 5 | | CAPACITOR-FXD .1UF +-20% 50VDC CER | 28480 | 0160-0576 |
| A9C16 | 0160-3878 | 6 | | CAPACITOR-FXD 1000PF +-20% 100VDC CER | 28480 | 0160-3878 |
| A9C17 | 0160-0576 | 5 | | CAPACITOR-FXD .1UF +-20% 50VDC CER | 28480 | 0160-0576 |
| A9C18 | 0160-0576 | 5 | | CAPACITOR-FXD .1UF +-20% 50VDC CER | 28480 | 0160-0576 |
| A9C19 | 0160-3874 | 2 | 1 | CAPACITOR-FXD 10PF +-5PF 200VDC CER | 28480 | 0160-3874 |
| A9C20 | 0160-0576 | 5 | | CAPACITOR-FXD .1UF +-20% 50VDC CER | 28480 | 0160-0576 |
| A9C21 | 0160-0576 | 5 | | CAPACITOR-FXD .1UF +-20% 50VDC CER | 28480 | 0160-0576 |
| A9C22 | 0180-2617 | 1 | | CAPACITOR-FXD 6.8UF+-10% 35VDC TA | 25088 | D6R8GS1B35K |
| A9C23 | 0160-0576 | 5 | | CAPACITOR-FXD .1UF +-20% 50VDC CER | 28480 | 0160-0576 |
| A9C24 | 0180-2617 | 1 | | CAPACITOR-FXD 6.8UF+-10% 35VDC TA | 25088 | D6R8GS1B35K |
| A9C25 | 0160-0576 | 5 | | CAPACITOR-FXD .1UF +-20% 50VDC CER | 28480 | 0160-0576 |
| A9C26 | 0160-0576 | 5 | | CAPACITOR-FXD .1UF +-20% 50VDC CER | 28480 | 0160-0576 |
| A9C27 | 0160-0576 | 5 | | CAPACITOR-FXD .1UF +-20% 50VDC CER | 28480 | 0160-0576 |
| A9C28 | 0160-3879 | 7 | 1 | CAPACITOR-FXD .01UF +-20% 100VDC CER | 28480 | 0160-3879 |
| A9CR1 | 1901-0639 | 4 | 4 | DIODE-PIN | 28480 | 5082-3080 |
| A9CR2 | 1901-0639 | 4 | | DIODE-PIN | 28480 | 5082-3080 |
| A9CR3 | 1901-0639 | 4 | | DIODE-PIN | 28480 | 5082-3080 |
| A9CR4 | 1901-0639 | 4 | | DIODE-PIN | 28480 | 5082-3080 |
| A9CR5 | 05335-80005 | 3 | 1 | DIODE-MATCHED SET OF 2(CR5 & CR14) | 28480 | 05335-80005 |
| A9CR6 | 1901-0050 | 3 | 2 | DIODE-SWITCHING 80V 200MA 2NS DD-35 | 28480 | 1901-0050 |
| A9CR7 | 1901-0050 | 3 | | DIODE-SWITCHING 80V 200MA 2NS DD-35 | 28480 | 1901-0050 |
| A9CR8 | 1901-1068 | 5 | 4 | DIODE-SM SIG SCHOTTKY | 28480 | 1901-1068 |
| A9CR9 | 1901-1068 | 5 | | DIODE-SM SIG SCHOTTKY | 28480 | 1901-1068 |
| A9CR10 | 1902-0551 | 1 | 2 | DIODE-ZNR 6.2V 5% PD=1W IR=10UA | 28480 | 1902-0551 |
| A9CR11 | 1901-1068 | 5 | | DIODE-SM SIG SCHOTTKY | 28480 | 1901-1068 |
| A9CR12 | 1901-1068 | 5 | | DIODE-SM SIG SCHOTTKY | 28480 | 1901-1068 |
| A9CR13 | 1902-0551 | 1 | | DIODE-ZNR 6.2V 5% PD=1W IR=10UA | 28480 | 1902-0551 |
| A9CR14 | 05335-80005 | 3 | | DIODE-MATCHED SET OF 2(CR5 & CR14) | 28480 | 05335-80005 |
| A9J1 | 1251-4275 | 3 | 1 | CONNECTOR 3-PIN H POST TYPE | 28480 | 1251-4275 |
| A9J3 | 1250-0835 | 1 | 1 | CONNECTOR-RF SMC H PC 50-OHM | 28480 | 1250-0835 |
| A9L1 | 9100-2272 | 5 | 1 | INDUCTOR RF-CH-MLD 47UH 10% .105DX.26LG | 28480 | 9100-2272 |
| A9L2 | 9100-2256 | 5 | 2 | INDUCTOR RF-CH-MLD 560NH 10% .105DX.26LG | 28480 | 9100-2256 |
| A9L3 | 9100-2255 | 4 | 1 | INDUCTOR RF-CH-MLD 470NH 10% .105DX.26LG | 28480 | 9100-2255 |
| A9L4 | 9100-2256 | 5 | | INDUCTOR RF-CH-MLD 560NH 10% .105DX.26LG | 28480 | 9100-2256 |
| A9L5 | 9100-1788 | 6 | 1 | CHOKE-WIDE BAND ZMAX=680 OHM@ 180 MHZ | 02114 | VK200 20/48 |
| A9Q1 | 1854-0345 | 8 | 1 | TRANSISTOR NPN 2N5179 SI TO-72 PD=200MW | 64713 | 2N5179 |
| A9R1 | 0698-7211 | 8 | 3 | RESISTOR 90.9 1% .05W F TC=0+-100 | 24546 | C3-1/8-T0-90R9-F |
| A9R2 | 0698-7211 | 8 | | RESISTOR 90.9 1% .05W F TC=0+-100 | 24546 | C3-1/8-T0-90R9-F |
| A9R3 | 0698-7228 | 7 | 2 | RESISTOR 464 1% .05W F TC=0+-100 | 24546 | C3-1/8-T0-464R-F |
| A9R4 | 0698-7222 | 1 | 3 | RESISTOR 261 1% .05W F TC=0+-100 | 24546 | C3-1/8-T0-261R-F |
| A9R5 | 0698-7228 | 7 | | RESISTOR 464 1% .05W F TC=0+-100 | 24546 | C3-1/8-T0-464R-F |
| A9R6 | 0698-7236 | 7 | 4 | RESISTOR 1K 1% .05W F TC=0+-100 | 24546 | C3-1/8-T0-1001-F |
| A9R7 | 0698-7198 | 0 | 3 | RESISTOR 26.1 1% .05W F TC=0+-100 | 24546 | C3-1/8-T0-26R1-F |
| A9R8 | 0698-7216 | 3 | 1 | RESISTOR 147 1% .05W F TC=0+-100 | 24546 | C3-1/8-T0-147R-F |
| A9R9 | 0698-7211 | 8 | | RESISTOR 90.9 1% .05W F TC=0+-100 | 24546 | C3-1/8-T0-90R9-F |
| A9R10 | 0698-7198 | 0 | | RESISTOR 26.1 1% .05W F TC=0+-100 | 24546 | C3-1/8-T0-26R1-F |
| A9R11 | 0698-7259 | 4 | 2 | RESISTOR 9.09K 1% .05W F TC=0+-100 | 24546 | C3-1/8-T0-9091-F |
| A9R12 | 0698-7205 | 0 | 1 | RESISTOR 51.1 1% .05W F TC=0+-100 | 24546 | C3-1/8-T0-51R1-F |
| A9R13 | 0698-7259 | 4 | | RESISTOR 9.09K 1% .05W F TC=0+-100 | 24546 | C3-1/8-T0-9091-F |
| A9R14 | 0698-7241 | 4 | 1 | RESISTOR 162K 1% .05W F TC=0+-100 | 24546 | C3-1/8-T0-1621-F |
| A9R15 | 0698-7242 | 5 | 1 | RESISTOR 1.78K 1% .05W F TC=0+-100 | 24546 | C3-1/8-T0-1781-F |
| A9R16 | 0757-0178 | 8 | 1 | RESISTOR 100 1% .25W F TC=0+-100 | 24546 | C5-1/4-T0-101-F |
| A9R17 | 0698-7252 | 7 | 1 | RESISTOR 4.64K 1% .05W F TC=0+-100 | 24546 | C3-1/8-T0-4641-F |
| A9R18 | 0698-7188 | 8 | 2 | RESISTOR 10 1% .05W F TC=0+-100 | 24546 | C3-1/8-T0-10R-F |
| A9R19 | 0698-7188 | 8 | | RESISTOR 10 1% .05W F TC=0+-100 | 24546 | C3-1/8-T0-10R-F |
| A9R20 | 0698-7222 | 1 | | RESISTOR 261 1% .05W F TC=0+-100 | 24546 | C3-1/8-T0-261R-F |

See introduction to this section for ordering information

*Indicates factory selected value

Reproduced with permission,
Courtesy of Agilent Technologies Inc.

Table 6-5. Option 030 "C" Channel Replaceable Parts (Continued)

| Reference Designation | HP Part Number | C D | Qty | Description | Mfr Code | Mfr Part Number |
|---|----------------|-----|-----|---|----------|----------------------|
| A9R21 | 0698-7222 | 1 | | RESISTOR 261 1% .05W F TC=0+-100 | 24546 | C3-1/8-T0-261R-F |
| A9R22 | 2100-1788 | 9 | 1 | RESISTOR-TRMR 500 10% C TOP-ADJ 1-TRN | 73138 | 82PR500 |
| A9R23 | 2100-1985 | 8 | 2 | RESISTOR-TRMR 20 20% C TOP-ADJ 1-TRN | 32997 | 3329H-1-200 |
| A9R24 | 2100-1965 | 8 | | RESISTOR-TRMR 20 20% C TOP-ADJ 1-TRN | 32997 | 3329H-1-200 |
| A9R25 | 0698-7236 | 7 | | RESISTOR 1K 1% .05W F TC=0+-100 | 24546 | C3-1/8-T0-1001-F |
| A9R26 | 0698-7236 | 7 | | RESISTOR 1K 1% .05W F TC=0+-100 | 24546 | C3-1/8-T0-1001-F |
| A9R27 | 0698-7198 | 0 | | RESISTOR 26.1 1% .05W F TC=0+-100 | 24546 | C3-1/8-T0-26R1-F |
| A9R28 | 0698-7288 | 9 | 1 | RESISTOR 147K 1% .05W F TC=0+-100 | 24546 | C3-1/8-T0-1473-F |
| A9R29 | 0698-7236 | 7 | | RESISTOR 1K 1% .05W F TC=0+-100 | 24546 | C3-1/8-T0-1001-F |
| A9U1 | 5888-7036 | 7 | 1 | 1.6 GHZ AMPLIFIER ASSEMBLY | 28480 | 5888-7036 |
| A9U2 | 1820-2382 | 6 | 1 | IC DIVR ECL DECD | 28480 | 1DC2A |
| A9U3 | 1820-1225 | 4 | 1 | IC FF ECL D-M/S DUAL | 04713 | MC10231P |
| A9U4 | 1826-0412 | 1 | 1 | IC COMPARATOR PRCN DUAL 8-DIP-P PKG | 27014 | LM393N |
| A9U5 | 1820-1112 | 8 | 1 | IC FF TTL LS D-TYPE POS-EDGE-TRIG | 31295 | SN74LS74AN |
| A9 MISCELLANEOUS PARTS | | | | | | |
| | 0360-0451 | 9 | 6 | TERMINAL-STUD SCL-PIN SWGRM-MTG | 28480 | 0360-0451 |
| | 0520-0128 | 7 | 4 | SCREW-MACH 2-56 .25-IN-LG PAN-HD-POZI | 28480 | 0520-0128 |
| | 0610-0003 | 8 | 4 | NUT-HEX-DBL-CHAM 2-56-THD .062-IN-THK | 28480 | 0610-0003 |
| | 2190-0014 | 1 | 4 | WASHER-LK INTL T NO. 2 .089-IN-ID | 28480 | 2190-0014 |
| | 05305-00010 | 6 | 3 | CLAMP-HEAT SINK (FOR U1) | 28480 | 05305-00010 |
| | 05335-00012 | 4 | 3 | CLAMP-HEAT SINK (FOR U2) | 28480 | 05335-00012 |
| | 1251-1556 | 7 | 16 | CONNECTOR-SGL CONT SKT .018-IN-BSC-SZ | 28480 | 1251-1556 |
| OPT. 030 REQUIRES THE FOLLOWING PARTS WHICH ARE NOT PART OF CIRCUIT BD A9. | | | | | | |
| A9H35 | 0370-1005 | 2 | 1 | KNOR-BASE-PTR 3/8JCK.125" ID | 28480 | 0370-1005 |
| A9W1 | 05335-60105 | 2 | 1 | CABLE ASSEMBLY-50-OHM INPUT | 28480 | 05335-60105 |
| A9W2 | 05335-60106 | 3 | 1 | CABLE ASSEMBLY-SENSITIVITY/A9W2R1 | 28480 | 05335-60106 |
| A9W2R1 | 2100-2635 | 7 | 1 | RESISTOR-VAR CONTROL CCP 50K 20% LIN | 28480 | 2100-2635 |
| | 2950-0060 | 9 | 2 | WASHER-LOCK INT-T 1/4-IN | 28480 | 2950-0060 |
| A9W3 | 05335-60109 | 6 | 1 | CABLE ASSEMBLY-EXT PREAMPL POWER | 28480 | 05335-60109 |
| A9W3J2 | 5060-0467 | 6 | 1 | CONNECTOR-MALE PROBE-PWR | 28480 | 5060-0467 |
| A9W2H32 | 2950-0072 | 3 | 2 | NUT-HEX-DBL-CHAM 1/4-32-THD .062-IN-THK | 00000 | ORDER BY DESCRIPTION |
| | 0590-0038 | 5 | 1 | NUT-HEX-DBL-CHAM 1/2-32 X 9/16 | 00000 | ORDER BY DESCRIPTION |
| | 2110-0301 | 1 | 1 | FUSE-125MA 125V | 28480 | 2110-0301 |
| | 2190-0068 | 5 | 1 | WASHER-LK INTL-T 1/2"DIA | 28480 | 2190-0068 |
| | 2190-0124 | 4 | 1 | WASHER-LK INTL T NO. 10 .195-IN-ID | 28480 | 2190-0124 |
| | 05305-20104 | 1 | 1 | HOLDER-FUSE SHELL | 28480 | 05305-20104 |
| | 05305-20105 | 2 | 1 | INSULATOR-FUSE | 28480 | 05305-20105 |
| | 05305-60205 | 7 | 1 | CONNECTOR ASSEMBLY-BNC (REMOVABLE) | 28480 | 05305-60205 |
| | 05305-60206 | 8 | 1 | CONNECTOR ASSEMBLY-SMC | 28480 | 05305-60206 |
| | 05335-00002 | 2 | | PANEL-FRONT (OPTION) | 28480 | 05335-00002 |
| | 05335-00008 | 8 | 1 | PANEL-FREQ "C" | 28480 | 05335-00008 |

See introduction to this section for ordering information
*Indicates factory selected valueReproduced with permission,
Courtesy of Agilent Technologies Inc.

Table 6-6. Option 040 Programmable Input Replaceable Parts

| Reference Designation | HP Part Number | C D | Qty | Description | Mfr Code | Mfr Part Number |
|-----------------------|----------------|--------|-----|---------------------------------------|----------|-----------------|
| A10 | 05335-60010 | 8 | 1 | BOARD ASSY-SWITCH PANEL (SERIES 2202) | 28480 | 05335-60010 |
| A10DS1 | 1990-0851 | 9 | 12 | LED-VISIBLE LUM-INT=1MCD IF=20MA-MAX | 28480 | 1990-0851 |
| A10DS2 | 1990-0851 | 9 | | LED-VISIBLE LUM-INT=1MCD IF=20MA-MAX | 28480 | 1990-0851 |
| A10DS3 | 1990-0851 | 9 | | LED-VISIBLE LUM-INT=1MCD IF=20MA-MAX | 28480 | 1990-0851 |
| A10DS4 | 1990-0851 | 9 | | LED-VISIBLE LUM-INT=1MCD IF=20MA-MAX | 28480 | 1990-0851 |
| A10DS5 | 1990-0851 | 9 | | LED-VISIBLE LUM-INT=1MCD IF=20MA-MAX | 28480 | 1990-0851 |
| A10DS6 | 1990-0851 | 9 | | LED-VISIBLE LUM-INT=1MCD IF=20MA-MAX | 28480 | 1990-0851 |
| A10DS7 | 1990-0851 | 9 | | LED-VISIBLE LUM-INT=1MCD IF=20MA-MAX | 28480 | 1990-0851 |
| A10DS8 | 1990-0851 | 9 | | LED-VISIBLE LUM-INT=1MCD IF=20MA-MAX | 28480 | 1990-0851 |
| A10DS9 | 1990-0851 | 9 | | LED-VISIBLE LUM-INT=1MCD IF=20MA-MAX | 28480 | 1990-0851 |
| A10DS10 | 1990-0851 | 9 | | LED-VISIBLE LUM-INT=1MCD IF=20MA-MAX | 28480 | 1990-0851 |
| A10DS11 | 1990-0851 | 9 | | LED-VISIBLE LUM-INT=1MCD IF=20MA-MAX | 28480 | 1990-0851 |
| A10DS12 | 1990-0851 | 9 | | LED-VISIBLE LUM-INT=1MCD IF=20MA-MAX | 28480 | 1990-0851 |
| A10J1 | 1251-6203 | 1 | 1 | CONNECTOR,16-PIN FEMALE | 28480 | 1251-6203 |
| A10S1 | 5060-9436 | 7 | 12 | PUSHBUTTON SWITCH P.C. MOUNT | 28480 | 5060-9436 |
| A10S2 | 5060-9436 | 7 | | PUSHBUTTON SWITCH P.C. MOUNT | 28480 | 5060-9436 |
| A10S3 | 5060-9436 | 7 | | PUSHBUTTON SWITCH P.C. MOUNT | 28480 | 5060-9436 |
| A10S4 | 5060-9436 | 7 | | PUSHBUTTON SWITCH P.C. MOUNT | 28480 | 5060-9436 |
| A10S5 | 5060-9436 | 7 | | PUSHBUTTON SWITCH P.C. MOUNT | 28480 | 5060-9436 |
| A10S6 | 5060-9436 | 7 | | PUSHBUTTON SWITCH P.C. MOUNT | 28480 | 5060-9436 |
| A10S7 | 5060-9436 | 7 | | PUSHBUTTON SWITCH P.C. MOUNT | 28480 | 5060-9436 |
| A10S8 | 5060-9436 | 7 | | PUSHBUTTON SWITCH P.C. MOUNT | 28480 | 5060-9436 |
| A10S9 | 5060-9436 | 7 | | PUSHBUTTON SWITCH P.C. MOUNT | 28480 | 5060-9436 |
| A10S10 | 5060-9436 | 7 | | PUSHBUTTON SWITCH P.C. MOUNT | 28480 | 5060-9436 |
| A10S11 | 5060-9436 | 7 | | PUSHBUTTON SWITCH P.C. MOUNT | 28480 | 5060-9436 |
| A10S12 | 5060-9436 | 7 | | PUSHBUTTON SWITCH P.C. MOUNT | 28480 | 5060-9436 |
| | | | | A10 MISCELLANEOUS PARTS | | |
| | 5041-0318 | 6 | 2 | SWITCH CAP/LITE PIPE DARK GREY | 28480 | 5041-0318 |
| | 5041-0252 | 7 | 10 | SWITCH CAP/LITE PIPE LIGHT GREY | 28480 | 5041-0252 |

See introduction to this section for ordering information

*Indicates factory selected value

Reproduced with permission,
Courtesy of Agilent Technologies Inc.

Table 6-6. Option 040 Programmable Input Replaceable Parts (Con't)

| Reference Designation | HP Part Number | C D | Qty | Description | Mfr Code | Mfr Part Number |
|-----------------------|----------------|-----|-----|--|----------|------------------|
| A11 | 05335-60011 | 9 | 1 | BOARD ASSEMBLY-AMPLIFIER (SERIES 2224) | 28480 | 05335-60011 |
| A11C1 | 0160-4557 | 0 | 8 | CAPACITOR-FXD .1UF +-20% 50VDC CER | 16299 | CAC04X7R104M050A |
| A11C2 | 0160-4557 | 0 | | CAPACITOR-FXD .1UF +-20% 50VDC CER | 16299 | CAC04X7R104M050A |
| A11C3 | 0160-4557 | 0 | | CAPACITOR-FXD .1UF +-20% 50VDC CER | 16299 | CAC04X7R104M050A |
| A11C4 | 0160-4557 | 0 | | CAPACITOR-FXD .1UF +-20% 50VDC CER | 16299 | CAC04X7R104M050A |
| A11C5 | 0160-4554 | 7 | 15 | CAPACITOR-FXD .01UF +-20% 50VDC CER | 28480 | 0160-4554 |
| A11C6 | 0160-0127 | 2 | 2 | CAPACITOR-FXD .1UF +-20% 25VDC CER | 28480 | 0160-0127 |
| A11C7 | 0160-0127 | 2 | | CAPACITOR-FXD .1UF +-20% 25VDC CER | 28480 | 0160-0127 |
| A11C8 | 0160-4554 | 7 | | CAPACITOR-FXD .01UF +-20% 50VDC CER | 28480 | 0160-4554 |
| A11C9 | 0160-4554 | 7 | | CAPACITOR-FXD .01UF +-20% 50VDC CER | 28480 | 0160-4554 |
| A11C10 | 0160-4554 | 7 | | CAPACITOR-FXD .01UF +-20% 50VDC CER | 28480 | 0160-4554 |
| A11C11 | 0160-4554 | 7 | | CAPACITOR-FXD .01UF +-20% 50VDC CER | 28480 | 0160-4554 |
| A11C12 | 0160-3879 | 7 | 8 | CAPACITOR-FXD .01UF +-20% 100VDC CER | 28480 | 0160-3879 |
| A11C13 | 0160-4554 | 7 | | CAPACITOR-FXD .01UF +-20% 50VDC CER | 28480 | 0160-4554 |
| A11C14 | 0160-3879 | 7 | | CAPACITOR-FXD .01UF +-20% 100VDC CER | 28480 | 0160-3879 |
| A11C15 | 0160-4554 | 7 | | CAPACITOR-FXD .01UF +-20% 50VDC CER | 28480 | 0160-4554 |
| A11C16 | 0160-4554 | 7 | | CAPACITOR-FXD .01UF +-20% 50VDC CER | 28480 | 0160-4554 |
| A11C17 | 0160-4554 | 7 | | CAPACITOR-FXD .01UF +-20% 50VDC CER | 28480 | 0160-4554 |
| A11C18 | 0160-3879 | 7 | | CAPACITOR-FXD .01UF +-20% 100VDC CER | 28480 | 0160-3879 |
| A11C19 | 0160-3879 | 7 | | CAPACITOR-FXD .01UF +-20% 100VDC CER | 28480 | 0160-3879 |
| A11C20 | 0160-4040 | 6 | 1 | CAPACITOR-FXD 1000PF +-5% 100VDC CER | 28480 | 0160-4040 |
| A11C21 | 0160-4481 | 9 | 1 | CAPACITOR-FXD 270PF +-5% 100VDC CER | 51642 | 150-100-NP0-271J |
| A11C22 | 0160-4554 | 7 | | CAPACITOR-FXD .01UF +-20% 50VDC CER | 28480 | 0160-4554 |
| A11C23 | 0160-3879 | 7 | | CAPACITOR-FXD .01UF +-20% 100VDC CER | 28480 | 0160-3879 |
| A11C24 | 0160-4554 | 7 | | CAPACITOR-FXD .01UF +-20% 50VDC CER | 28480 | 0160-4554 |
| A11C25 | 0160-3879 | 7 | | CAPACITOR-FXD .01UF +-20% 100VDC CER | 28480 | 0160-3879 |
| A11C26 | 0160-3879 | 7 | | CAPACITOR-FXD .01UF +-20% 100VDC CER | 28480 | 0160-3879 |
| A11C27 | 0160-4554 | 7 | | CAPACITOR-FXD .01UF +-20% 50VDC CER | 28480 | 0160-4554 |
| A11C28 | 0160-3874 | 2 | 2 | CAPACITOR-FXD 10PF +-1.5PF 200VDC CER | 28480 | 0160-3874 |
| A11C29 | 0160-3874 | 2 | | CAPACITOR-FXD 10PF +-1.5PF 200VDC CER | 28480 | 0160-3874 |
| A11C30 | 0160-4554 | 7 | | CAPACITOR-FXD .01UF +-20% 50VDC CER | 28480 | 0160-4554 |
| A11C31 | 0160-4554 | 7 | | CAPACITOR-FXD .01UF +-20% 50VDC CER | 28480 | 0160-4554 |
| A11C32 | 0160-3879 | 7 | | CAPACITOR-FXD .01UF +-20% 100VDC CER | 28480 | 0160-3879 |
| A11C33 | 0160-4557 | 0 | | CAPACITOR-FXD .1UF +-20% 50VDC CER | 16299 | CAC04X7R104M050A |
| A11C34 | 0160-4557 | 0 | | CAPACITOR-FXD .1UF +-20% 50VDC CER | 16299 | CAC04X7R104M050A |
| A11C35 | 0160-4557 | 0 | | CAPACITOR-FXD .1UF +-20% 50VDC CER | 16299 | CAC04X7R104M050A |
| A11C36 | 0160-4557 | 0 | | CAPACITOR-FXD .1UF +-20% 50VDC CER | 16299 | CAC04X7R104M050A |
| A11C37 | 0160-4554 | 7 | | CAPACITOR-FXD .01UF +-20% 50VDC CER | 28480 | 0160-4554 |
| A11CR1 | 1901-0376 | 6 | 2 | DIODE-GEN PRP 35V 50MA DO-35 | 28480 | 1901-0376 |
| A11CR2 | 1901-0376 | 6 | | DIODE-GEN PRP 35V 50MA DO-35 | 28480 | 1901-0376 |
| A11CR3 | 1901-0050 | 3 | 3 | DIODE-SWITCHING 80V 200MA 2NS DO-35 | 28480 | 1901-0050 |
| A11CR4 | 1902-3097 | 6 | 1 | DIODE-ZNR 5.23V 2% DO-35 PD=.4W | 28480 | 1902-3097 |
| A11CR5 | 1901-0050 | 3 | | DIODE-SWITCHING 80V 200MA 2NS DO-35 | 28480 | 1901-0050 |
| A11CR6 | 1901-0050 | 3 | | DIODE-SWITCHING 80V 200MA 2NS DO-35 | 28480 | 1901-0050 |
| A11J1 | 1200-0614 | 9 | 2 | SOCKET-RLY 18-CONT DIP-SLDR | 28480 | 1200-0614 |
| A11J2 | 1200-0614 | 9 | | SOCKET-RLY 18-CONT DIP-SLDR | 28480 | 1200-0614 |
| A11J3 | 1251-0472 | 4 | 2 | CONNECTOR-PC EDGE 6-CONT/ROW 2-ROWS | 28480 | 1251-0472 |
| A11J4 | 1250-0835 | 1 | 2 | CONNECTOR-RF SMC M PC 50-OHM | 28480 | 1250-0835 |
| A11J5 | 1250-0835 | 1 | | CONNECTOR-RF SMC M PC 50-OHM | 28480 | 1250-0835 |
| A11J6 | 1251-0472 | 4 | | CONNECTOR-PC EDGE 6-CONT/ROW 2-ROWS | 28480 | 1251-0472 |
| A11L1 | 9100-1788 | 6 | 4 | CHOKE-WIDE BAND ZMAX=680 OHM@ 180 MHZ | 02114 | UK200 20/48 |
| A11L2 | 9100-1788 | 6 | | CHOKE-WIDE BAND ZMAX=680 OHM@ 180 MHZ | 02114 | UK200 20/48 |
| A11L3 | 9100-1788 | 6 | | CHOKE-WIDE BAND ZMAX=680 OHM@ 180 MHZ | 02114 | UK200 20/48 |
| A11L4 | 9100-1788 | 6 | | CHOKE-WIDE BAND ZMAX=680 OHM@ 180 MHZ | 02114 | UK200 20/48 |
| A11Q1 | 1854-0246 | 8 | 9 | TRANSISTOR NPN SI PD=350MW FT=250MHZ | 04713 | SPS 233 |
| A11Q2 | 1854-0246 | 8 | | TRANSISTOR NPN SI PD=350MW FT=250MHZ | 04713 | SPS 233 |
| A11Q3 | 1854-0246 | 8 | | TRANSISTOR NPN SI PD=350MW FT=250MHZ | 04713 | SPS 233 |
| A11Q4 | 1854-0246 | 8 | | TRANSISTOR NPN SI PD=350MW FT=250MHZ | 04713 | SPS 233 |
| A11Q5 | 1854-0246 | 8 | | TRANSISTOR NPN SI PD=350MW FT=250MHZ | 04713 | SPS 233 |
| A11Q6 | 1854-0246 | 8 | | TRANSISTOR NPN SI PD=350MW FT=250MHZ | 04713 | SPS 233 |
| A11Q7 | 1854-0246 | 8 | | TRANSISTOR NPN SI PD=350MW FT=250MHZ | 04713 | SPS 233 |
| A11Q8 | 1854-0246 | 8 | | TRANSISTOR NPN SI PD=350MW FT=250MHZ | 04713 | SPS 233 |
| A11Q9 | 1854-0246 | 8 | | TRANSISTOR NPN SI PD=350MW FT=250MHZ | 04713 | SPS 233 |
| A11Q10 | 1853-0036 | 2 | 9 | TRANSISTOR PNP SI PD=310MW FT=250MHZ | 28480 | 1853-0036 |
| A11Q11 | 1853-0036 | 2 | | TRANSISTOR PNP SI PD=310MW FT=250MHZ | 28480 | 1853-0036 |
| A11Q12 | 1853-0036 | 2 | | TRANSISTOR PNP SI PD=310MW FT=250MHZ | 28480 | 1853-0036 |
| A11Q13 | 1853-0036 | 2 | | TRANSISTOR PNP SI PD=310MW FT=250MHZ | 28480 | 1853-0036 |
| A11Q14 | 1853-0036 | 2 | | TRANSISTOR PNP SI PD=310MW FT=250MHZ | 28480 | 1853-0036 |
| A11Q15 | 1853-0036 | 2 | | TRANSISTOR PNP SI PD=310MW FT=250MHZ | 28480 | 1853-0036 |

See introduction to this section for ordering information
*Indicates factory selected valueReproduced with permission,
Courtesy of Agilent Technologies Inc.

Table 6-6. Option 040 Programmable Input Replaceable Parts (Con't)

| Reference Designation | HP Part Number | C D | Qty | Description | Mfr Code | Mfr Part Number |
|-----------------------|----------------|-----|-----|---------------------------------------|----------|------------------|
| A11Q16 | 1853-0036 | 2 | | TRANSISTOR PNP SI PD=310MW FT=250MHZ | 28480 | 1853-0036 |
| A11Q17 | 1853-0036 | 2 | | TRANSISTOR PNP SI PD=310MW FT=250MHZ | 28480 | 1853-0036 |
| A11Q18 | 1853-0036 | 2 | | TRANSISTOR PNP SI PD=310MW FT=250MHZ | 28480 | 1853-0036 |
| A11R1 | 0757-0280 | 3 | 6 | RESISTOR 1K 1% .125W F TC=0+-100 | 24546 | C4-1/8-T0-1001-F |
| A11R2 | 0757-0280 | 3 | | RESISTOR 1K 1% .125W F TC=0+-100 | 24546 | C4-1/8-T0-1001-F |
| A11R3 | 0757-0443 | 0 | 4 | RESISTOR 11K 1% .125W F TC=0+-100 | 24546 | C4-1/8-T0-1162-F |
| A11R4 | 0698-6943 | 1 | 4 | RESISTOR 20K .1% .125W F TC=0+-50 | 28480 | 0698-6943 |
| A11R5 | 0757-0447 | 4 | 4 | RESISTOR 16.2K 1% .125W F TC=0+-100 | 24546 | C4-1/8-T0-1622-F |
| A11R6 | 0757-0443 | 0 | | RESISTOR 11K 1% .125W F TC=0+-100 | 24546 | C4-1/8-T0-1102-F |
| A11R7 | 0757-0443 | 0 | | RESISTOR 11K 1% .125W F TC=0+-100 | 24546 | C4-1/8-T0-1102-F |
| A11R8 | 0698-6943 | 1 | | RESISTOR 20K .1% .125W F TC=0+-50 | 28480 | 0698-6943 |
| A11R9 | 0698-6943 | 1 | | RESISTOR 20K .1% .125W F TC=0+-50 | 28480 | 0698-6943 |
| A11R10 | 0698-4008 | 5 | 8 | RESISTOR 40K 1% .125W F TC=0+-100 | 24546 | C4-1/8-T0-4002-F |
| A11R11 | 0757-0447 | 4 | | RESISTOR 16.2K 1% .125W F TC=0+-100 | 24546 | C4-1/8-T0-1622-F |
| A11R12 | 0698-4008 | 5 | | RESISTOR 40K 1% .125W F TC=0+-100 | 24546 | C4-1/8-T0-4002-F |
| A11R13 | 0757-0442 | 9 | 6 | RESISTOR 10K 1% .125W F TC=0+-100 | 24546 | C4-1/8-T0-1002-F |
| A11R14 | 0698-6369 | 5 | 2 | RESISTOR 1M .1% .25W F TC=0+-25 | 28480 | 0698-6369 |
| A11R15 | 0757-0447 | 4 | | RESISTOR 16.2K 1% .125W F TC=0+-100 | 24546 | C4-1/8-T0-1622-F |
| A11R16 | 0698-4008 | 5 | | RESISTOR 40K 1% .125W F TC=0+-100 | 24546 | C4-1/8-T0-4002-F |
| A11R17 | 0698-6369 | 5 | | RESISTOR 1M .1% .25W F TC=0+-25 | 28480 | 0698-6369 |
| A11R18 | 0698-4008 | 5 | | RESISTOR 40K 1% .125W F TC=0+-100 | 24546 | C4-1/8-T0-4002-F |
| A11R19 | 0698-3437 | 2 | 1 | RESISTOR 133 1% .125W F TC=0+-100 | 24546 | C4-1/8-T0-133R-F |
| A11R20 | 0698-6943 | 1 | | RESISTOR 20K .1% .125W F TC=0+-50 | 28480 | 0698-6943 |
| A11R21 | 0757-0416 | 7 | 1 | RESISTOR 511 1% .125W F TC=0+-100 | 24546 | C4-1/8-T0-511R-F |
| A11R22 | 0698-4008 | 5 | | RESISTOR 40K 1% .125W F TC=0+-100 | 24546 | C4-1/8-T0-4002-F |
| A11R23 | 0698-4008 | 5 | | RESISTOR 40K 1% .125W F TC=0+-100 | 24546 | C4-1/8-T0-4002-F |
| A11R24 | 0757-0447 | 4 | | RESISTOR 16.2K 1% .125W F TC=0+-100 | 24546 | C4-1/8-T0-1622-F |
| A11R25 | 0757-0442 | 9 | | RESISTOR 10K 1% .125W F TC=0+-100 | 24546 | C4-1/8-T0-1002-F |
| A11R26 | 0757-0399 | 5 | 1 | RESISTOR 82.5 1% .125W F TC=0+-100 | 24546 | C4-1/8-T0-82R5-F |
| A11R27 | 0698-8094 | 7 | 1 | RESISTOR 1.82M 1% .5W F TC=0+-100 | 28480 | 0698-8094 |
| A11R28 | 0698-7203 | 8 | 2 | RESISTOR 42.2 1% .05W F TC=0+-100 | 24546 | C3-1/8-T0-42R2-F |
| A11R29 | 0698-7212 | 9 | 2 | RESISTOR 100 1% .05W F TC=0+-100 | 24546 | C3-1/8-T0-100R-F |
| A11R30 | 0698-7222 | 1 | 4 | RESISTOR 261 1% .05W F TC=0+-100 | 24546 | C3-1/8-T0-261R-F |
| A11R31 | 0698-7226 | 5 | 2 | RESISTOR 383 1% .05W F TC=0+-100 | 24546 | C3-1/8-T0-383R-F |
| A11R32 | 0757-0465 | 6 | 2 | RESISTOR 100K 1% .125W F TC=0+-100 | 24546 | C4-1/8-T0-1003-F |
| A11R33 | 0757-0442 | 9 | | RESISTOR 10K 1% .125W F TC=0+-100 | 24546 | C4-1/8-T0-1002-F |
| A11R34 | 0757-0443 | 0 | | RESISTOR 11K 1% .125W F TC=0+-100 | 24546 | C4-1/8-T0-1102-F |
| A11R35 | 0698-4008 | 5 | | RESISTOR 40K 1% .125W F TC=0+-100 | 24546 | C4-1/8-T0-4002-F |
| A11R36 | 0698-7222 | 1 | | RESISTOR 261 1% .05W F TC=0+-100 | 24546 | C3-1/8-T0-261R-F |
| A11R37 | 0698-7215 | 2 | 2 | RESISTOR 133 1% .05W F TC=0+-100 | 24546 | C3-1/8-T0-133R-F |
| A11R38 | 0698-7210 | 7 | 2 | RESISTOR 82.5 1% .05W F TC=0+-100 | 24546 | C3-1/8-T0-82R5-F |
| A11R39 | 1810-0364 | 9 | 1 | NETWORK-RES 6-S1P470.0 OHM X 5 | 01121 | 206A471 |
| A11R40 | 0698-7203 | 8 | | RESISTOR 42.2 1% .05W F TC=0+-100 | 24546 | C3-1/8-T0-42R2-F |
| A11R41 | 0698-7212 | 9 | | RESISTOR 100 1% .05W F TC=0+-100 | 24546 | C3-1/8-T0-100R-F |
| A11R42 | 0698-7222 | 1 | | RESISTOR 261 1% .05W F TC=0+-100 | 24546 | C3-1/8-T0-261R-F |
| A11R43 | 0698-7226 | 5 | | RESISTOR 383 1% .05W F TC=0+-100 | 24546 | C3-1/8-T0-383R-F |
| A11R44 | 0757-0442 | 9 | | RESISTOR 10K 1% .125W F TC=0+-100 | 24546 | C4-1/8-T0-1002-F |
| A11R45 | 0757-0465 | 6 | | RESISTOR 100K 1% .125W F TC=0+-100 | 24546 | C4-1/8-T0-1003-F |
| A11R46 | 0698-4008 | 5 | | RESISTOR 40K 1% .125W F TC=0+-100 | 24546 | C4-1/8-T0-4002-F |
| A11R47 | 0698-7210 | 7 | | RESISTOR 82.5 1% .05W F TC=0+-100 | 24546 | C3-1/8-T0-82R5-F |
| A11R48 | 2100-3383 | 4 | 4 | RESISTOR-TRMR 50 10% C TOP-ADJ 1-TRN | 28480 | 2100-3383 |
| A11R49 | 0757-0398 | 4 | 2 | RESISTOR 75 1% .125W F TC=0+-100 | 24546 | C4-1/8-T0-75R0-F |
| A11R50 | 0757-1108 | 6 | 2 | RESISTOR 300 1% .125W F TC=0+-100 | 24546 | C4-1/8-T0-301-F |
| A11R51 | 0757-1108 | 6 | | RESISTOR 300 1% .125W F TC=0+-100 | 24546 | C4-1/8-T0-301-F |
| A11R52 | 0757-0398 | 4 | | RESISTOR 75 1% .125W F TC=0+-100 | 24546 | C4-1/8-T0-75R0-F |
| A11R53 | 2100-3383 | 4 | | RESISTOR-TRMR 50 10% C TOP-ADJ 1-TRN | 28480 | 2100-3383 |
| A11R54 | 0698-7215 | 2 | | RESISTOR 133 1% .05W F TC=0+-100 | 24546 | C3-1/8-T0-133R-F |
| A11R55 | 0757-0442 | 9 | | RESISTOR 10K 1% .125W F TC=0+-100 | 24546 | C4-1/8-T0-1002-F |
| A11R56 | 0757-0280 | 3 | | RESISTOR 1K 1% .125W F TC=0+-100 | 24546 | C4-1/8-T0-1001-F |
| A11R57 | 0757-0280 | 3 | | RESISTOR 1K 1% .125W F TC=0+-100 | 24546 | C4-1/8-T0-1001-F |
| A11R58 | 0698-6612 | 1 | 1 | RESISTOR 2K .1% .125W F TC=0+-50 | 28480 | 0698-6612 |
| A11R59 | 0698-3491 | 8 | 1 | RESISTOR 1K .1% .125W F TC=0+-50 | 28480 | 0698-3491 |
| A11R60 | 1810-0382 | 1 | 1 | NETWORK-RES 10-S1P10.0 OHM X 9 | 01121 | 210A101 |
| A11R61 | 0698-7222 | 1 | | RESISTOR 261 1% .05W F TC=0+-100 | 24546 | C3-1/8-T0-261R-F |
| A11R62 | 0757-0442 | 9 | | RESISTOR 10K 1% .125W F TC=0+-100 | 24546 | C4-1/8-T0-1002-F |
| A11R63 | 1810-0280 | 8 | 1 | NETWORK-RES 10-S1P10.0K OHM X 9 | 01121 | 210A103 |
| A11R64 | 0757-0280 | 3 | | RESISTOR 1K 1% .125W F TC=0+-100 | 24546 | C4-1/8-T0-1001-F |
| A11R65 | 0757-0280 | 3 | | RESISTOR 1K 1% .125W F TC=0+-100 | 24546 | C4-1/8-T0-1001-F |
| A11R66 | 0757-0317 | 7 | 1 | RESISTOR 1.33K 1% .125W F TC=0+-100 | 24546 | C4-1/8-T0-1331-F |
| A11R67 | 1810-0277 | 3 | 1 | NETWORK-RES 10-S1P2.2K OHM X 9 | 01121 | 210A222 |
| A11R68 | 1810-0275 | 1 | 1 | NETWORK-RES 10-S1P1.0K OHM X 9 | 01121 | 210A102 |
| A11R69 | 2100-0568 | 1 | 2 | RESISTOR-TRMR 100 10% C TOP-ADJ 1-TRN | 28480 | 2100-0568 |
| A11R70 | 2100-3383 | 4 | | RESISTOR-TRMR 50 10% C TOP-ADJ 1-TRN | 28480 | 2100-3383 |
| A11R71 | 0757-0403 | 2 | 2 | RESISTOR 121 1% .125W F TC=0+-100 | 24546 | C4-1/8-T0-121R-F |
| A11R72 | 0757-0428 | 1 | 2 | RESISTOR 1.62K 1% .125W F TC=0+-100 | 24546 | C4-1/8-T0-1621-F |
| A11R73 | 0757-0403 | 2 | | RESISTOR 121 1% .125W F TC=0+-100 | 24546 | C4-1/8-T0-121R-F |
| A11R74 | 2100-3383 | 4 | | RESISTOR-TRMR 50 10% C TOP-ADJ 1-TRN | 28480 | 2100-3383 |
| A11R75 | 2100-0568 | 1 | | RESISTOR-TRMR 100 10% C TOP-ADJ 1-TRN | 28480 | 2100-0568 |

See introduction to this section for ordering information
*Indicates factory selected value

Table 6-6. Option 040 Programmable Input Replaceable Parts (Con't)

| Reference Designation | HP Part Number | C D | Qty | Description | Mfr Code | Mfr Part Number |
|-----------------------|----------------|-----|-----|--|----------|------------------|
| A11R76 | 0757-0428 | 1 | | RESISTOR 1.62K 1% .125W F TC=0+-100 | 24546 | C4-1/8-T0-1621-F |
| A11U1 | 1826-0315 | 3 | 3 | IC OP AMP GP QUAD 14-DIP-P PKG | 27014 | LM348N |
| A11U2 | 1826-0609 | 8 | 3 | IC MULTIPLXR ANLG 16-DIP-C PKG | 06665 | MUX08FQ |
| A11U3 | 1826-0315 | 3 | | IC OP AMP GP QUAD 14-DIP-P PKG | 27014 | LM348N |
| A11U4 | 1826-0609 | 8 | | IC MULTIPLXR ANLG 16-DIP-C PKG | 06665 | MUX08FQ |
| A11U5 | 1826-0610 | 1 | 1 | IC MULTIPLXR 4-CHAN-ANLG DUAL 16-DIP-C | 06665 | MUX24FQ |
| A11U6 | 1858-0040 | 8 | 1 | TRANSISTOR ARRAY 16-PIN PLSTC DIP | 3L585 | CA3127E |
| A11U7 | 1820-1359 | 5 | 1 | IC MUXR/DATA-SEL ECL 4-T0-1-LINE DUAL | 04713 | MC10174P |
| A11U8 | 1820-1173 | 1 | 1 | IC XLTR ECL TTL-T0-ECL QUAD 2-INP | 04713 | MC10124L |
| A11U9 | 1826-0315 | 3 | | IC OP AMP GP QUAD 14-DIP-P PKG | 27014 | LM348N |
| A11U10 | 1826-0575 | 7 | 1 | IC CONV V/FREQ 14-DIP-P PKG | 15818 | 9400CJ |
| A11U11 | 1826-0609 | 8 | | IC MULTIPLXR ANLG 16-DIP-C PKG | 06665 | MUX08FQ |
| A11U12 | 1820-0794 | 0 | 1 | IC FF ECL D-M/S | 04713 | MC1670L |
| A11U13 | 1820-1917 | 1 | 1 | IC BFR TTL LS LINE DRVR OCTL | 01295 | SN74LS240N |
| A11U14 | 1820-1196 | 8 | 2 | IC FF TTL LS D-TYPE POS-EDGE-TRIG COM | 01295 | SN74LS174N |
| A11U15 | 1820-1196 | 8 | | IC FF TTL LS D-TYPE POS-EDGE-TRIG COM | 01295 | SN74LS174N |
| A11U16 | 1820-1858 | 9 | 3 | IC FF TTL LS D-TYPE OCTL | 01295 | SN74LS377N |
| A11U17 | 1820-1858 | 9 | | IC FF TTL LS D-TYPE OCTL | 01295 | SN74LS377N |
| A11U18 | 1820-1858 | 9 | | IC FF TTL LS D-TYPE OCTL | 01295 | SN74LS377N |
| A11U19 | 1820-1240 | 3 | 2 | IC DCDR TTL S 3-T0-8-LINE 3-INP | 01295 | SN74S138N |
| A11U20 | 1820-1240 | 3 | | IC DCDR TTL S 3-T0-8-LINE 3-INP | 01295 | SN74S138N |
| A11U21 | 1820-1984 | 2 | 2 | IC CONV 10-B-D/A 16-DIP-C PKG | 24355 | AD561KD |
| A11U22 | 1826-0135 | 5 | 1 | IC OP AMP GP DUAL 14-DIP-C PKG | 07263 | U4747DM |
| A11U23 | 1820-1984 | 2 | | IC CONV 10-B-D/A 16-DIP-C PKG | 24355 | AD561KD |
| A11U24 | 1820-1445 | 0 | 1 | IC LCH TTL LS 4-BIT | 01295 | SN74LS375N |
| A11U25 | 1820-1197 | 9 | 1 | IC GATE TTL LS NAND QUAD 2-INP | 01295 | SN74LS00N |
| A11XU7 | 1200-0482 | 9 | 4 | SOCKET-IC 16-CONT DIP-SLDR | 28480 | 1200-0482 |
| A11XU21 | 1200-0482 | 9 | | SOCKET-IC 16-CONT DIP-SLDR | 28480 | 1200-0482 |
| A11XU23 | 1200-0482 | 9 | | SOCKET-IC 16-CONT DIP-SLDR | 28480 | 1200-0482 |
| A11XU23 | 1200-0482 | 9 | | SOCKET-IC 16-CONT DIP-SLDR | 28480 | 1200-0482 |
| | 0360-1682 | 0 | 7 | TERMINAL-STUD SGL-TUR PRESS-MTG (TP1,2,COM,ATL,BTL,GAS,GAB) | 28480 | 0360-1682 |

See introduction to this section for ordering information

*Indicates factory selected value

Reproduced with permission,
Courtesy of Agilent Technologies Inc.

Table 6-6. Option 040 Programmable Input Replaceable Parts (Con't)

| Reference Designation | HP Part Number | C D | Qty | Description | Mfr Code | Mfr Part Number |
|---|----------------|-----|-----|--|----------|------------------|
| A12 | 05335-60012 | 0 | 1 | BOARD ASSEMBLY-AMPLIFIER (SERIES 2232) | 28480 | 05335-60012 |
| A12C2 | 0160-3877 | 5 | 4 | CAPACITOR-FXD 100PF +-20% 200VDC CER | 28480 | 0160-3877 |
| A12C3 | 0180-2814 | 0 | 4 | CAPACITOR-FXD 22UF+-20% 10VDC TA | 28480 | 0180-2814 |
| A12C4 | 0160-4233 | 9 | 4 | CAPACITOR-FXD .47UF +-5% 50VDC MET-POLYC | 28480 | 0160-4233 |
| A12C5 | 0180-2814 | 0 | 4 | CAPACITOR-FXD 22UF+-20% 10VDC TA | 28480 | 0180-2814 |
| A12C6 | 0180-2821 | 9 | 4 | CAPACITOR-FXD 22UF+-20% 35VDC TA | 28480 | 0180-2821 |
| A12C7 | 0180-2821 | 9 | | CAPACITOR-FXD 22UF+-20% 35VDC TA | 28480 | 0180-2821 |
| A12C8 | 0160-4325 | 0 | 4 | CAPACITOR-FXD .33UF +-5% 50VDC MET-POLYC | 28480 | 0160-4325 |
| A12C9 | 0160-3879 | 7 | 26 | CAPACITOR-FXD .01UF +-20% 100VDC CER | 28480 | 0160-3879 |
| A12C10 | 0160-3879 | 7 | | CAPACITOR-FXD .01UF +-20% 100VDC CER | 28480 | 0160-3879 |
| A12C11 | 0160-3879 | 7 | | CAPACITOR-FXD .01UF +-20% 100VDC CER | 28480 | 0160-3879 |
| A12C12 | 0160-3879 | 7 | | CAPACITOR-FXD .01UF +-20% 100VDC CER | 28480 | 0160-3879 |
| A12C13 | 0160-4233 | 9 | | CAPACITOR-FXD .47UF +-5% 50VDC MET-POLYC | 28480 | 0160-4233 |
| A12C14 | 0160-4325 | 0 | | CAPACITOR-FXD .33UF +-5% 50VDC MET-POLYC | 28480 | 0160-4325 |
| A12C15 | 0160-3879 | 7 | | CAPACITOR-FXD .01UF +-20% 100VDC CER | 28480 | 0160-3879 |
| A12C16 | 0160-3879 | 7 | | CAPACITOR-FXD .01UF +-20% 100VDC CER | 28480 | 0160-3879 |
| A12C17 | 0160-3877 | 5 | | CAPACITOR-FXD 100PF +-20% 200VDC CER | 28480 | 0160-3877 |
| A12C18 | 0160-3879 | 7 | | CAPACITOR-FXD .01UF +-20% 100VDC CER | 28480 | 0160-3879 |
| A12C19 | 0160-3879 | 7 | | CAPACITOR-FXD .01UF +-20% 100VDC CER | 28480 | 0160-3879 |
| A12C20 | 0160-3879 | 7 | | CAPACITOR-FXD .01UF +-20% 100VDC CER | 28480 | 0160-3879 |
| A12C21 | 0160-3879 | 7 | | CAPACITOR-FXD .01UF +-20% 100VDC CER | 28480 | 0160-3879 |
| A12C22 | 0160-3879 | 7 | | CAPACITOR-FXD .01UF +-20% 100VDC CER | 28480 | 0160-3879 |
| A12C24 | 0160-4424 | 0 | 2 | CAPACITOR-FXD .047UF +-20% 500VDC CER | 51642 | 400-500-X7R-473M |
| A12C25 | 0160-4703 | 8 | 2 | CAPACITOR-FXD 68PF +-5% 500VDC CER 0+-30 | 28480 | 0160-4703 |
| A12C26 | 0160-3879 | 7 | | CAPACITOR-FXD .01UF +-20% 100VDC CER | 28480 | 0160-3879 |
| A12C27 | 0160-3879 | 7 | | CAPACITOR-FXD .01UF +-20% 100VDC CER | 28480 | 0160-3879 |
| A12C28 | 0160-5245 | 5 | 2 | CAPACITOR-FXD 3.3PF +-5% 500VDC CER | 28480 | 0160-5245 |
| A12C29 | 0160-4040 | 6 | 2 | CAPACITOR-FXD 1000PF +-5% 100VDC CER | 28480 | 0160-4040 |
| A12C30 | 0121-0473 | 9 | 2 | CAPACITOR-V TRMR-CER 5-25PF 100V PC-MTG | 28480 | 0121-0473 |
| A12C31 | 0160-3879 | 7 | | CAPACITOR-FXD .01UF +-20% 100VDC CER | 28480 | 0160-3879 |
| A12C32 | 0160-3879 | 7 | | CAPACITOR-FXD .01UF +-20% 100VDC CER | 28480 | 0160-3879 |
| A12C33 | 0160-4040 | 6 | | CAPACITOR-FXD 1000PF +-5% 100VDC CER | 28480 | 0160-4040 |
| A12C35 | 0160-3879 | 7 | | CAPACITOR-FXD .01UF +-20% 100VDC CER | 28480 | 0160-3879 |
| A12C36 | 0160-4703 | 8 | | CAPACITOR-FXD 68PF +-5% 500VDC CER 0+-30 | 28480 | 0160-4703 |
| A12C37 | 0160-4424 | 0 | | CAPACITOR-FXD .047UF +-20% 500VDC CER | 51642 | 400-500-X7R-473M |
| A12C38 | 0180-2814 | 0 | | CAPACITOR-FXD 22UF+-20% 10VDC TA | 28480 | 0180-2814 |
| A12C39 | 0160-5245 | 5 | | CAPACITOR-FXD 3.3PF +-5% 500VDC CER | 28480 | 0160-5245 |
| A12C40 | 0160-3879 | 7 | | CAPACITOR-FXD .01UF +-20% 100VDC CER | 28480 | 0160-3879 |
| A12C41 | 0160-3879 | 7 | | CAPACITOR-FXD .01UF +-20% 100VDC CER | 28480 | 0160-3879 |
| A12C42 | 0160-3879 | 7 | | CAPACITOR-FXD .01UF +-20% 100VDC CER | 28480 | 0160-3879 |
| A12C43 | 0160-3879 | 7 | | CAPACITOR-FXD .01UF +-20% 100VDC CER | 28480 | 0160-3879 |
| A12C44 | 0160-3879 | 7 | | CAPACITOR-FXD .01UF +-20% 100VDC CER | 28480 | 0160-3879 |
| A12C45 | 0160-3879 | 7 | | CAPACITOR-FXD .01UF +-20% 100VDC CER | 28480 | 0160-3879 |
| A12C46 | 0121-0473 | 9 | | CAPACITOR-V TRMR-CER 5-25PF 100V PC-MTG | 28480 | 0121-0473 |
| A12C47 | 0160-3879 | 7 | | CAPACITOR-FXD .01UF +-20% 100VDC CER | 28480 | 0160-3879 |
| A12C48 | 0160-3879 | 7 | | CAPACITOR-FXD .01UF +-20% 100VDC CER | 28480 | 0160-3879 |
| A12C49 | 0160-3879 | 7 | | CAPACITOR-FXD .01UF +-20% 100VDC CER | 28480 | 0160-3879 |
| A12C50 | 0160-3879 | 7 | | CAPACITOR-FXD .01UF +-20% 100VDC CER | 28480 | 0160-3879 |
| A12C51 | 0180-2821 | 9 | | CAPACITOR-FXD 22UF+-20% 35VDC TA | 28480 | 0180-2821 |
| A12C52 | 0160-3877 | 5 | | CAPACITOR-FXD 100PF +-20% 200VDC CER | 28480 | 0160-3877 |
| A12C53 | 0160-3877 | 5 | | CAPACITOR-FXD 100PF +-20% 200VDC CER | 28480 | 0160-3877 |
| A12C54 | 0180-2814 | 0 | | CAPACITOR-FXD 22UF+-20% 10VDC TA | 28480 | 0180-2814 |
| A12C55 | 0160-4325 | 0 | | CAPACITOR-FXD .33UF +-5% 50VDC MET-POLYC | 28480 | 0160-4325 |
| A12C56 | 0160-4325 | 0 | | CAPACITOR-FXD .33UF +-5% 50VDC MET-POLYC | 28480 | 0160-4325 |
| A12C57 | 0160-4233 | 9 | | CAPACITOR-FXD .47UF +-5% 50VDC MET-POLYC | 28480 | 0160-4233 |
| A12C58 | 0180-2821 | 9 | | CAPACITOR-FXD 22UF+-20% 35VDC TA | 28480 | 0180-2821 |
| A12C59 | 0160-4233 | 9 | | CAPACITOR-FXD .47UF +-5% 50VDC MET-POLYC | 28480 | 0160-4233 |
| A12C60 | 0160-5244 | 4 | 2 | CAPACITOR-FXD 12PF +-5% 500VDC CER 0+-30 | 28480 | 0160-5244 |
| A12C61 | 0160-5244 | 4 | | CAPACITOR-FXD 12PF +-5% 500VDC CER 0+-30 | 28480 | 0160-5244 |
| A12CR1 | 1991-1080 | 1 | 2 | DIODE-SCHOTTKY 1N5817 20V 1A | 28480 | 1991-1080 |
| A12CR2,CR6,CR7 | 05335-80003 | 1 | 6 | DIODE MATCHED SET OF FOUR | 28480 | 05335-80003 |
| A12CR3,CR8,CR9 | 05335-80003 | 1 | | DIODE MATCHED SET OF FOUR | 28480 | 05335-80003 |
| A12CR4,5,10,&11 | 05335-80003 | 1 | | DIODE MATCHED SET OF FOUR | 28480 | 05335-80003 |
| MATCHED DIODES AVAILABLE ONLY IN SETS OF FOUR | | | | | | |

See introduction to this section for ordering information
*Indicates factory selected value

Table 6-6. Option 040 Programmable Input Replaceable Parts (Con't)

| Reference Designation | HP Part Number | C D | Qty | Description | Mfr Code | Mfr Part Number |
|-----------------------|----------------|-----|-----|--|----------|----------------------|
| A12CR11+ | 05335-80003 | 1 | | DIODE-MATCHED SET | 28480 | 05335-80003 |
| A12CR12 | 1902-0057 | 2 | 2 | DIODE-ZNR 6.49V 5% DO-35 PD=.4W | 28480 | 1902-0057 |
| A12CR13 | 1902-0041 | 4 | 2 | DIODE-ZNR 5.11V 5% DO-35 PD=.4W | 28480 | 1902-0041 |
| A12CR14 | 1901-0050 | 3 | 9 | DIODE-SWITCHING 80V 200MA 2NS DO-35 | 28480 | 1901-0050 |
| A12CR15 | 1902-3136 | 4 | 2 | DIODE-ZNR 8.06V 5% DO-35 PD=.4W | 28480 | 1902-3136 |
| A12CR16 | 1901-0050 | 3 | | DIODE-SWITCHING 80V 200MA 2NS DO-35 | 28480 | 1901-0050 |
| A12CR17 | 1901-0050 | 3 | | DIODE-SWITCHING 80V 200MA 2NS DO-35 | 28480 | 1901-0050 |
| A12CR18 | 1901-0050 | 3 | | DIODE-SWITCHING 80V 200MA 2NS DO-35 | 28480 | 1901-0050 |
| A12CR19 | 1901-0050 | 3 | | DIODE-SWITCHING 80V 200MA 2NS DO-35 | 28480 | 1901-0050 |
| A12CR20 | 1901-0050 | 3 | | DIODE-SWITCHING 80V 200MA 2NS DO-35 | 28480 | 1901-0050 |
| A12CR21 | 1902-3136 | 4 | | DIODE-ZNR 8.06V 5% DO-35 PD=.4W | 28480 | 1902-3136 |
| A12CR22 | 1901-1080 | 1 | | DIODE-SCHOTTKY 1N5817 20V 1A | 28480 | 1901-1080 |
| A12CR23 | 1901-0050 | 3 | | DIODE-SWITCHING 80V 200MA 2NS DO-35 | 28480 | 1901-0050 |
| A12CR24 | 1901-0050 | 3 | | DIODE-SWITCHING 80V 200MA 2NS DO-35 | 28480 | 1901-0050 |
| A12CR25,26,29,&30 | 05335-80003 | 1 | | DIODE-MATCHED SET OF FOUR | 28480 | 05335-80003 |
| A12CR27 | 1902-0041 | 4 | | DIODE-ZNR 5.11V 5% DO-35 PD=.4W | 28480 | 1902-0041 |
| A12CR28 | 1901-0050 | 3 | | DIODE-SWITCHING 80V 200MA 2NS DO-35 | 28480 | 1901-0050 |
| A12CR31,CR32,CR36 | 05335-80003 | 1 | | DIODE-MATCHED SET OF FOUR | 28480 | 05335-80003 |
| A12CR33,CR34,CR37 | 05335-80003 | 1 | | DIODE-MATCHED SET OF FOUR | 28480 | 05335-80003 |
| A12CR35 | 1902-0057 | 2 | | DIODE-ZNR 6.49V 5% DO-35 PD=.4W | 28480 | 1902-0057 |
| A12CR36+ | 05335-80003 | 1 | | DIODE-MATCHED SET | 28480 | 05335-80003 |
| A12CR37+ | 05335-80003 | 1 | | DIODE-MATCHED SET | 28480 | 05335-80003 |
| A12DS1 | 1990-0487 | 7 | 2 | LED-LAMP LUM-INT=1MCD IF=20MA-MAX BVR=5V | 28480 | 5082-4584 |
| A12DS2 | 1990-0487 | 7 | | LED-LAMP LUM-INT=1MCD IF=20MA-MAX BVR=5V | 28480 | 5082-4584 |
| A12H10 | 2950-0035 | 8 | 1 | NUT-HEX-DBL-CHAM 15/32-32-1HD | 00000 | ORDER BY DESCRIPTION |
| A12J2 | 1200-0614 | 9 | 2 | SOCKET-RLY 18-CONT DIP-SLDR | 28480 | 1200-0614 |
| A12J3 | 1250-1671 | 5 | 2 | CONNECTOR-RF BNC FEM SGL-HOLE-RR 50-OHM | 28480 | 1250-1671 |
| A12J4 | 1250-0835 | 1 | 2 | CONNECTOR-RF SMC M PC 50-OHM | 28480 | 1250-0835 |
| A12J6 | 1250-1671 | 5 | | CONNECTOR-RF BNC FEM SGL-HOLE-RR 50-OHM | 28480 | 1250-1671 |
| A12J7 | 1200-0614 | 9 | | SOCKET-RLY 18-CONT DIP-SLDR | 28480 | 1200-0614 |
| A12J8 | 1250-0835 | 1 | | CONNECTOR-RF SMC M PC 50-OHM | 28480 | 1250-0835 |
| A12K1 | 0490-0508 | 2 | 9 | RELAY 2C 12VDC-COIL .5A 28VDC | 28480 | 0490-0508 |
| A12K2 | 0490-0508 | 2 | | RELAY 2C 12VDC-COIL .5A 28VDC | 28480 | 0490-0508 |
| A12K3 | 0490-0508 | 2 | | RELAY 2C 12VDC-COIL .5A 28VDC | 28480 | 0490-0508 |
| A12K4 | 0490-0508 | 2 | | RELAY 2C 12VDC-COIL .5A 28VDC | 28480 | 0490-0508 |
| A12K5 | 0490-0508 | 2 | | RELAY 2C 12VDC-COIL .5A 28VDC | 28480 | 0490-0508 |
| A12K6 | 0490-0508 | 2 | | RELAY 2C 12VDC-COIL .5A 28VDC | 28480 | 0490-0508 |
| A12K7 | 0490-0508 | 2 | | RELAY 2C 12VDC-COIL .5A 28VDC | 28480 | 0490-0508 |
| A12K8 | 0490-0508 | 2 | | RELAY 2C 12VDC-COIL .5A 28VDC | 28480 | 0490-0508 |
| A12K9 | 0490-0508 | 2 | | RELAY 2C 12VDC-COIL .5A 28VDC | 28480 | 0490-0508 |
| A12L1 | 05335-80001 | 9 | 2 | INDUCTOR | 28480 | 05335-80001 |
| A12L2 | 05335-80001 | 9 | | INDUCTOR | 28480 | 05335-80001 |
| A12Q2 | 1854-0636 | 0 | 4 | TRANSISTOR NPN SI TO-72 PD=350MW | 28480 | 1854-0636 |
| A12Q3 | 1854-0686 | 0 | 4 | TRANSISTOR NPN SI TO-72 PD=200MW FT=4GHZ | 28480 | 1854-0686 |
| A12Q4 | 1854-0686 | 0 | | TRANSISTOR NPN SI TO-72 PD=200MW FT=4GHZ | 28480 | 1854-0686 |
| A12Q5 | 1854-0636 | 0 | | TRANSISTOR NPN SI TO-72 PD=350MW | 28480 | 1854-0636 |
| A12Q6† | 1855-0212 | 0 | 2 | TRANSISTOR J-FET N-CHAN SI | 28480 | 1855-0212 |
| A12Q6† | 1855-0300 | 7 | 2 | TRANSISTOR J-FET N-CHAN D-MODE TO-18 | 28480 | 1855-0300 |
| A12Q8† | 1855-0212 | 0 | | TRANSISTOR J-FET N-CHAN SI | 28480 | 1855-0212 |
| A12Q8† | 1855-0300 | 7 | | TRANSISTOR J-FET N-CHAN D-MODE TO-18 | 28480 | 1855-0300 |
| A12Q9 | 1854-0636 | 0 | | TRANSISTOR NPN SI TO-72 PD=350MW | 28480 | 1854-0636 |
| A12Q10 | 1854-0686 | 0 | | TRANSISTOR NPN SI TO-72 PD=200MW FT=4GHZ | 28480 | 1854-0686 |
| A12Q11 | 1854-0636 | 0 | | TRANSISTOR NPN SI TO-72 PD=350MW | 28480 | 1854-0636 |
| A12Q12 | 1854-0686 | 0 | | TRANSISTOR NPN SI TO-72 PD=200MW FT=4GHZ | 28480 | 1854-0686 |
| A12R2 | 2100-3359 | 4 | 4 | RESISTOR-TRMR 2M 20% C SIDE-ADJ 1-TRN | 28480 | 2100-3359 |
| A12R3 | | | | NOT ASSIGNED | | |
| A12R4 | 0698-7267 | 4 | 8 | RESISTOR 19.6K 1% .05W F TC=0+-100 | 24546 | C3-1/8-T0-1962-F |
| A12R5 | 0698-7267 | 4 | | RESISTOR 19.6K 1% .05W F TC=0+-100 | 24546 | C3-1/8-T0-1962-F |
| A12R7* | 0699-0071 | 6 | 8 | RESISTOR 4.64M 1% .125W F TC=0+-100 | 28480 | 3699-0071 |
| A12R8* | 0699-0071 | 6 | | RESISTOR 4.64M 1% .125W F TC=0+-100 | 28480 | 0699-0071 |
| A12R9 | 0698-7227 | 6 | 4 | RESISTOR 422 1% .05W F TC=0+-100 | 24546 | C3-1/8-T0-422R-F |
| A12R10 | 0698-7212 | 9 | 2 | RESISTOR 100 1% .05W F TC=0+-100 | 24546 | C3-1/8-T0-100R-F |
| A12R12 | 0698-7209 | 4 | 2 | RESISTOR 75 1% .05W F TC=0+-100 | 24546 | C3-1/8-T0-75R-F |
| A12R13 | 0698-7224 | 3 | 4 | RESISTOR 316 1% .05W F TC=0+-100 | 24546 | C3-1/8-T0-316R-F |
| A12R14 | 0698-7224 | 3 | | RESISTOR 316 1% .05W F TC=0+-100 | 24546 | C3-1/8-T0-316R-F |
| A12R15 | 0698-7218 | 5 | 2 | RESISTOR 178 1% .05W F TC=0+-100 | 24546 | C3-1/8-T0-178R-F |
| A12R16* | 0699-0071 | 6 | | RESISTOR 4.64M 1% .125W F TC=0+-100 | 28480 | 3699-0071 |
| A12R17* | 0699-0071 | 6 | | RESISTOR 4.64M 1% .125W F TC=0+-100 | 28480 | 0699-0071 |
| A12R18 | 0698-7267 | 4 | | RESISTOR 19.6K 1% .05W F TC=0+-100 | 24546 | C3-1/8-T0-1962-F |

†1855-0300 and 1855-0212 TRANSISTORS ARE DIRECTLY INTERCHANGEABLE.

See introduction to this section for ordering information
*Indicates factory selected valueReproduced with permission,
Courtesy of Agilent Technologies Inc.

Table 6-6. Option 040 Programmable Input Replaceable Parts (Con't)

| Reference Designation | HP Part Number | C D | Qty | Description | Mfr Code | Mfr Part Number |
|-----------------------|----------------|-----|-----|--|----------|--------------------|
| A12R19 | 0698-7267 | 4 | | RESISTOR 19.6K 1% .05W F TC=0+-100 | 24546 | C3-1/8-T0-1962-F |
| A12R20 | 0698-7249 | 2 | 4 | RESISTOR 3.48K 1% .05W F TC=0+-100 | 24546 | C3-1/8-T0-3481-F |
| A12R21 | 2100-3359 | 4 | | RESISTOR-TRMR 2M 20% C SIDE-ADJ 1-TRN | 28480 | 2100-3359 |
| A12R22 | 0698-7205 | 0 | 8 | RESISTOR 51.1 1% .05W F TC=0+-100 | 24546 | C3-1/8-T0-51R1-F |
| A12R23 | 0698-7249 | 2 | | RESISTOR 3.48K 1% .05W F TC=0+-100 | 24546 | C3-1/8-T0-3481-F |
| A12R24 | 0698-7205 | 0 | | RESISTOR 51.1 1% .05W F TC=0+-100 | 24546 | C3-1/8-T0-51R1-F |
| A12R25 | 0698-7198 | 0 | 9 | RESISTOR 26.1 1% .05W F TC=0+-100 | 24546 | C3-1/8-T0-26R1-F |
| A12R26 | 0698-7198 | 0 | | RESISTOR 26.1 1% .05W F TC=0+-100 | 24546 | C3-1/8-T0-26R1-F |
| A12R27 | 0698-7205 | 0 | | RESISTOR 51.1 1% .05W F TC=0+-100 | 24546 | C3-1/8-T0-51R1-F |
| A12R28 | 2100-3802 | 2 | 2 | RESISTOR-VAR W/SW 10K 20% LIN SPST-NO | 28480 | 2100-3802 |
| A12R29 | 0698-3922 | 0 | 4 | RESISTOR 487K .1% .125W F TC=0+-50 | 28480 | 0698-3922 |
| A12R30 | 0698-0087 | 2 | 2 | RESISTOR 316 1% .25W F TC=0+-100 | 24546 | C5-1/4-T0-3160-F |
| A12R31 | 0698-7227 | 6 | | RESISTOR 422 1% .05W F TC=0+-100 | 24546 | C3-1/8-T0-422R-F |
| A12R32 | 0698-7247 | 0 | 2 | RESISTOR 2.87K 1% .05W F TC=0+-100 | 24546 | C3-1/8-T0-2871-F |
| A12R33 | 0698-7238 | 9 | 4 | RESISTOR 1.21K 1% .05W F TC=0+-100 | 24546 | C3-1/8-T0-1211-F |
| A12R34 | 0698-7284 | 5 | 2 | RESISTOR 100K 1% .05W F TC=0+-100 | 24546 | C3-1/8-T0-1003-F |
| A12R35 | 0698-7198 | 0 | | RESISTOR 26.1 1% .05W F TC=0+-100 | 24546 | C3-1/8-T0-26R1-F |
| A12R36 | 0699-0073 | 8 | 2 | RESISTOR 10M 1% .125W F TC=0+-150 | 28480 | 0699-0073 |
| A12R37 | 0698-7205 | 0 | | RESISTOR 51.1 1% .05W F TC=0+-100 | 24546 | C3-1/8-T0-51R1-F |
| A12R38 | 0699-0676 | 7 | 2 | RESISTOR-511K OHM .1% .125W F TC=0+-50 | 28480 | 0699-0676 |
| A12R39 | 0698-6433 | 4 | 4 | RESISTOR 100 1% .25W F TC=0+-100 | 28480 | 0698-6433 |
| A12R40 | 0698-7252 | 7 | 2 | RESISTOR 4.64K 1% .05W F TC=0+-100 | 24546 | C3-1/8-T0-4641-F |
| A12R41 | 0698-6433 | 4 | | RESISTOR 100 1% .25W F TC=0+-100 | 28480 | 0698-6433 |
| A12R42 | 0757-0416 | 7 | 2 | RESISTOR 511 1% .125W F TC=0+-100 | 24546 | C4-1/8-T0-511R-F |
| A12R43 | 2100-3274 | 2 | 2 | RESISTOR-TRMR 10K 10% C SIDE-ADJ 1-TRN | 28480 | 2100-3274 |
| A12R44 | 0698-6400 | 5 | 2 | RESISTOR 900K 1% .25W F TC=0+-100 | 19701 | MF52C1/4-T0-9003-F |
| A12R45 | 0698-7245 | 8 | 2 | RESISTOR 2.37K 1% .05W F TC=0+-100 | 24546 | C3-1/8-T0-2371-F |
| A12R46 | 0698-7238 | 9 | | RESISTOR 1.21K 1% .05W F TC=0+-100 | 24546 | C3-1/8-T0-1211-F |
| A12R47 | 0698-7236 | 7 | 2 | RESISTOR 1K 1% .05W F TC=0+-100 | 24546 | C3-1/8-T0-1001-F |
| A12R48 | 0698-7216 | 3 | 2 | RESISTOR 147 1% .05W F TC=0+-100 | 24546 | C3-1/8-T0-147R-F |
| A12R49 | | | | NOT ASSIGNED | | |
| A12R50 | 0698-7198 | 0 | | RESISTOR 26.1 1% .05W F TC=0+-100 | 24546 | C3-1/8-T0-26R1-F |
| A12R51 | 0698-7241 | 4 | 2 | RESISTOR 1.62K 1% .05W F TC=0+-100 | 24546 | C3-1/8-T0-1621-F |
| A12R52 | 0698-6430 | 1 | 2 | RESISTOR 111K .5% .125W F TC=0+-100 | 28480 | 0698-6430 |
| A12R53 | 2100-3273 | 1 | 2 | RESISTOR-TRMR 2K 10% C SIDE-ADJ 1-TRN | 28480 | 2100-3273 |
| A12R54 | 0698-3922 | 0 | | RESISTOR 487K .1% .125W F TC=0+-50 | 28480 | 0698-3922 |
| A12R55 | 0698-3905 | 9 | 2 | RESISTOR 513K .1% .125W F TC=0+-50 | 28480 | 0698-3905 |
| A12R56 | 0698-7245 | 8 | | RESISTOR 2.37K 1% .05W F TC=0+-100 | 24546 | C3-1/8-T0-2371-F |
| A12R57 | 0698-7238 | 9 | | RESISTOR 1.21K 1% .05W F TC=0+-100 | 24546 | C3-1/8-T0-1211-F |
| A12R58 | 0698-3905 | 9 | | RESISTOR 513K .1% .125W F TC=0+-50 | 28480 | 0698-3905 |
| A12R59 | 0698-7198 | 0 | | RESISTOR 26.1 1% .05W F TC=0+-100 | 24546 | C3-1/8-T0-26R1-F |
| A12R60 | 0698-7216 | 3 | | RESISTOR 147 1% .05W F TC=0+-100 | 24546 | C3-1/8-T0-147R-F |
| A12R61 | 0698-6433 | 4 | | RESISTOR 100 1% .25W F TC=0+-100 | 28480 | 0698-6433 |
| A12R62 | | | | NOT ASSIGNED | | |
| A12R63 | | | | NOT ASSIGNED | | |
| A12R64 | 0698-7236 | 7 | | RESISTOR 1K 1% .05W F TC=0+-100 | 24546 | C3-1/8-T0-1001-F |
| A12R65 | 0698-6433 | 4 | | RESISTOR 100 1% .25W F TC=0+-100 | 28480 | 0698-6433 |
| A12R66 | 0698-3922 | 0 | | RESISTOR 487K .1% .125W F TC=0+-50 | 28480 | 0698-3922 |
| A12R67 | | | | NOT ASSIGNED | | |
| A12R68 | 0698-6400 | 5 | | RESISTOR 900K 1% .25W F TC=0+-100 | 19701 | MF52C1/4-T0-9003-F |
| A12R69 | 0698-7238 | 9 | | RESISTOR 1.21K 1% .05W F TC=0+-100 | 24546 | C3-1/8-T0-1211-F |
| A12R70 | 0757-0416 | 7 | | RESISTOR 511 1% .125W F TC=0+-100 | 24546 | C4-1/8-T0-511R-F |
| A12R71 | 0699-0073 | 8 | | RESISTOR 10M 1% .125W F TC=0+-150 | 28480 | 0699-0073 |
| A12R72 | 0698-7198 | 0 | | RESISTOR 26.1 1% .05W F TC=0+-100 | 24546 | C3-1/8-T0-26R1-F |
| A12R75 | 0698-7227 | 6 | | RESISTOR 422 1% .05W F TC=0+-100 | 24546 | C3-1/8-T0-422R-F |
| A12R76 | 0699-0676 | 7 | | RESISTOR-511K OHM .1% .125W F TC=0+-50 | 28480 | 0699-0676 |
| A12R77 | 0698-7198 | 0 | | RESISTOR 26.1 1% .05W F TC=0+-100 | 24546 | C3-1/8-T0-26R1-F |
| A12R78 | 0698-3922 | 0 | | RESISTOR 487K .1% .125W F TC=0+-50 | 28480 | 0698-3922 |
| A12R79 | 0698-7227 | 6 | | RESISTOR 422 1% .05W F TC=0+-100 | 24546 | C3-1/8-T0-422R-F |
| A12R80 | 2100-3802 | 2 | | RESISTOR-VAR W/SW 10K 20% LIN SPST-NO | 28480 | 2100-3802 |
| A12R81 | 0698-7212 | 9 | | RESISTOR 100 1% .05W F TC=0+-100 | 24546 | C3-1/8-T0-100R-F |
| A12R82 | 0698-7218 | 5 | | RESISTOR 178 1% .05W F TC=0+-100 | 24546 | C3-1/8-T0-178R-F |
| A12R83 | 0698-7205 | 0 | | RESISTOR 51.1 1% .05W F TC=0+-100 | 24546 | C3-1/8-T0-51R1-F |
| A12R84 | 0698-6430 | 1 | | RESISTOR 111K .5% .125W F TC=0+-100 | 28480 | 0698-6430 |
| A12R85 | 0698-7249 | 2 | | RESISTOR 3.48K 1% .05W F TC=0+-100 | 24546 | C3-1/8-T0-3481-F |
| A12R86 | 0698-7205 | 0 | | RESISTOR 51.1 1% .05W F TC=0+-100 | 24546 | C3-1/8-T0-51R1-F |
| A12R87 | 0698-7209 | 4 | | RESISTOR 75 1% .05W F TC=0+-100 | 24546 | C3-1/8-T0-75R0-F |
| A12R88 | 0698-7205 | 0 | | RESISTOR 51.1 1% .05W F TC=0+-100 | 24546 | C3-1/8-T0-51R1-F |
| A12R89 | 0698-7249 | 2 | | RESISTOR 3.48K 1% .05W F TC=0+-100 | 24546 | C3-1/8-T0-3481-F |
| A12R90 | 0698-0087 | 2 | | RESISTOR 316 1% .25W F TC=0+-100 | 24546 | C5-1/4-T0-3160-F |
| A12R91 | 0698-7267 | 4 | | RESISTOR 19.6K 1% .05W F TC=0+-100 | 24546 | C3-1/8-T0-1962-F |
| A12R92 | 0698-7267 | 4 | | RESISTOR 19.6K 1% .05W F TC=0+-100 | 24546 | C3-1/8-T0-1962-F |
| A12R93 | 0698-7198 | 0 | | RESISTOR 26.1 1% .05W F TC=0+-100 | 24546 | C3-1/8-T0-26R1-F |
| A12R94 | 0698-7198 | 0 | | RESISTOR 26.1 1% .05W F TC=0+-100 | 24546 | C3-1/8-T0-26R1-F |
| A12R95 | 0698-7224 | 3 | | RESISTOR 316 1% .05W F TC=0+-100 | 24546 | C3-1/8-T0-316R-F |

See introduction to this section for ordering information

*Indicates factory selected value

Reproduced with permission,
Courtesy of Agilent Technologies Inc.

Table 6-6. Option 040 Programmable Input Replaceable Parts (Con't)

| Reference Designation | HP Part Number | C D | Qty | Description | Mfr Code | Mfr Part Number |
|-----------------------|----------------|--------|-----|---|----------|------------------|
| A12R96 | 0698-7224 | 3 | | RESISTOR 316 1% .05W F TC=0+-100 | 24546 | C3-1/8-T0-316R-F |
| A12R97 | 0698-7247 | 0 | | RESISTOR 2.87K 1% .05W F TC=0+-100 | 24546 | C3-1/8-T0-2871-F |
| A12R98 | 0698-7284 | 5 | | RESISTOR 100K 1% .05W F TC=0+-100 | 24546 | C3-1/8-T0-1003-F |
| A12R99 | 0698-7205 | 0 | | RESISTOR 51.1 1% .05W F TC=0+-100 | 24546 | C3-1/8-T0-51R1-F |
| A12R100* | 0699-0071 | 6 | | RESISTOR 4.64M 1% .125W F TC=0+-100 | 28480 | 0699-0071 |
| A12R101* | 0699-0071 | 6 | | RESISTOR 4.64M 1% .125W F TC=0+-100 | 28480 | 0699-0071 |
| A12R102 | 0698-7252 | 7 | | RESISTOR 4.64K 1% .05W F TC=0+-100 | 24546 | C3-1/8-T0-4641-F |
| A12R103 | 0698-7267 | 4 | | RESISTOR 19.6K 1% .05W F TC=0+-100 | 24546 | C3-1/8-T0-1962-F |
| A12R104 | 0698-7267 | 4 | | RESISTOR 19.6K 1% .05W F TC=0+-100 | 24546 | C3-1/8-T0-1962-F |
| A12R105 | 2100-3273 | 1 | | RESISTOR-TRMR 2K 10% C SIDE-ADJ 1-TRN | 28480 | 2100-3273 |
| A12R106* | 0699-0071 | 6 | | RESISTOR 4.64M 1% .125W F TC=0+-100 | 28480 | 0699-0071 |
| A12R107 | 2100-3359 | 4 | | RESISTOR-TRMR 2M 20% C SIDE-ADJ 1-TRN | 28480 | 2100-3359 |
| A12R108* | 0699-0071 | 6 | | RESISTOR 4.64M 1% .125W F TC=0+-100 | 28480 | 0699-0071 |
| A12R109 | 0698-7241 | 4 | | RESISTOR 1.62K 1% .05W F TC=0+-100 | 24546 | C3-1/8-T0-1621-F |
| A12R110 | 2100-3274 | 2 | | RESISTOR-TRMR 10K 10% C SIDE-ADJ 1-TRN | 28480 | 2100-3274 |
| A12R111 | 2100-3359 | 4 | | RESISTOR-TRMR 2M 20% C SIDE-ADJ 1-TRN | 28480 | 2100-3359 |
| A12R112 | 0698-7277 | 6 | 2 | RESISTOR 51.1K 1% .05W F TC=0+-100 | 24546 | C3-1/8-T0-5112-F |
| A12R113 | 0698-7277 | 6 | | RESISTOR 51.1K 1% .05W F TC=0+-100 | 24546 | C3-1/8-T0-5112-F |
| A12S1 | | | | NSR P/O R80 & R28 TRIG CONTROL | | |
| A12S2 | | | | NSR P/O R80 & R28 TRIG CONTROL | | |
| A12U1 | 1826-0600 | 9 | 2 | IC OP AMP LOW-BIAS-H-IMPD QUAD 14-DIP-P | 01295 | TL074ACN |
| A12U2 | 1826-0570 | 2 | 2 | IC | 28480 | 1826-0570 |
| A12U3 | 1826-0035 | 4 | 2 | IC OP AMP LOW-DRIFT TO-99 PKG | 27014 | LM308AH |
| A12U4 | 1826-0035 | 4 | | IC OP AMP LOW-DRIFT TO-99 PKG | 27014 | LM308AH |
| A12U5 | 1826-0570 | 2 | | IC | 28480 | 1826-0570 |
| A12U6 | 1826-0600 | 9 | | IC OP AMP LOW-BIAS-H-IMPD QUAD 14-DIP-P | 01295 | TL074ACN |
| | | | | A12 MISCELLANEOUS PARTS | | |
| | 0340-0092 | 2 | 4 | TERMINAL-SOLDER SPCL-FDTHRU PRESS-MTG | 28480 | 0340-0092 |
| | 1205-0061 | 0 | 2 | HEAT SINK TO-5/T0-39-CS | 28480 | 1205-0061 |
| H10 | 1250-0035 | 8 | 2 | NUT-HEX-DBL-CHAM 15/32-32-THD | 28480 | 2950-0035 |
| | 4040-1616 | 6 | 2 | STANDOFF-LED | 28480 | 4040-1616 |

See introduction to this section for ordering information
*Indicates factory selected valueReproduced with permission,
Courtesy of Agilent Technologies Inc.

Table 6-7. Manufacturers Code List

| MFR. NO. | MANUFACTURER NAME | ADDRESS | ZIP CODE |
|----------|---|-------------------|----------|
| S0545 | Nippon Electric Company | Tokyo, Japan | |
| 00000 | Any Satisfactory Supplier | | |
| 00853 | Sangamo Elec. Co. So. Carolina Div. | Pickens, SC | 29671 |
| 01121 | Allen-Bradley Co. | Milwaukee, WI | 53204 |
| 01295 | Texas Instr. Inc. Semicond. Cmpnt. Div. | Dallas, TX | 75222 |
| 02111 | Spectrol Electronics Corp. | City of Ind., CA | 91745 |
| 02114 | Ferroxcube Corp. | Saugerties, NY | 12477 |
| 03508 | GE Co. Semiconductor Prod. Dept. | Auburn, NY | 13201 |
| 03888 | KDI Pyrofilm Corp. | Whippany, NJ | 07981 |
| 04713 | Motorola Semiconductor Products | Phoenix, AZ | 85008 |
| 06665 | Precision Monolithics Inc. | Santa Clara, CA | 95050 |
| 07263 | Fairchild Semiconductor Div. | Mountain View, CA | 94042 |
| 15818 | Teledyne Semiconductor | Mountain View, CA | 94043 |
| 16299 | Corning Gl. Wk. Elec. Cmpnt. Div. | Raleigh, NC | 27604 |
| 19701 | Mepco/Electra Corp. | Mineral Wells, TX | 76067 |
| 23936 | Pamotor Div. William J. Purdy | Burlingame, CA | 94010 |
| 24355 | Analog Devices Inc. | Norwood, MA | 02062 |
| 24546 | Corning Glass Works (Bradford) | Bradford, PA | 16701 |
| 25088 | Siemens Corp. | Iselin, NJ | 08830 |
| 27014 | National Semiconductor Corp. | Santa Clara, CA | 95051 |
| 28480 | Hewlett-Packard Co. Corporate Hq. | Palo Alto, CA | 94304 |
| 3L585 | RCA Corp., Sold State Division | Sommerville, NJ | 08876 |
| 32293 | Intersil Inc. | Cupertino, CA | 95014 |
| 32997 | Bourns Inc. Trimpot Prod. Div. | Riverside, CA | 92507 |
| 4N833 | ETRI, Inc. | Monroe, NC | 60521 |
| 51642 | Centre Engineering Inc. | State College, PA | 16801 |
| 52072 | Circuit Assembly Corp. | Costa Mesa, CA | 92626 |
| 52763 | Stettner Electronics Inc. | Chattanooga, TN | 13035 |
| 55576 | Synertek | Santa Clara, CA | 95051 |
| 56289 | Sprague Electric Co. | North Adams, MA | 01247 |
| 72136 | Electro Motive Corp. | Florence, SC | 06226 |
| 73138 | Beckman Instruments Inc. Helipot Div. | Fullerton, CA | 92634 |
| 75915 | Littelfuse Inc. | Des Plaines, IL | 60016 |
| 76381 | 3M Company | St. Paul, MN | 55101 |
| 8E175 | Burr Brown Co. | Tucson, AZ | 35801 |
| 84411 | TRW Capacitor Div. | Ogallala, NE | 69153 |
| 91637 | Dale Electronics Inc. | Columbus, NE | 68601 |
| 98291 | Sealectro Corp. | Mamaroneck, NY | 10544 |

SECTION VII MANUAL CHANGES

7-1. INTRODUCTION

7-2. This section contains information necessary to adapt this manual to older instruments by making manual changes to “backdate” the manual for a particular instrument configuration as determined by the Serial Prefix Number or complete Serial Number on the rear of the instrument.

7-3. MANUAL CHANGES

7-4. This manual applies directly to model 5335A Universal Frequency Counters with Serial Prefix No. 2232A and includes any Option 040 circuit boards with Series Number 2232.

7-5. As engineering changes are made, newer instruments may have Serial Prefix numbers higher than 2232A or circuit boards for options with series numbers higher than 2232. Manuals for these instruments

will be supplied with MANUAL CHANGES, printed on yellow paper, containing the required information. Replace affected pages or change existing information as directed in the MANUAL CHANGES. Contact the nearest Hewlett-Packard Sales and Service Office if the change information is missing.

7-6. OLDER INSTRUMENTS

7-7. If your instrument has a Serial Prefix Number or an option circuit board series number lower than 2232A, refer to *Table 7-1* and perform the manual backdating change(s) that applies to your instrument. Older instruments are at the bottom of the table. The terms “or above” and “or below” used in *Table 7-1*, or the changes, refer to instrument serial prefix or series numbers. Newer instruments manufactured after any prefix/series number are identified by the term “or above”. Older instruments made before any prefix/series number are referred to by “or below”.

Table 7-1. Manual Backdating

| If Instrument Has Serial Prefix or Option Series | Change Number | Circuit Board or Circuits Involved |
|---|--|--|
| 2232A 2224A 2220A 2216A 2208A | NONE 1 1,2 1,2,3 1,2,3,4 | NO BACKDATING CHANGES A12 A2, A3, A5-A7, A11, and A12 A4, A11 A4 |
| 2202A02446 OR ABOVE 2202A02445 OR BELOW 2152A 2140A 2134A | 1,2,3,4,5 1 through 6 1 through 7 1 through 8 1 through 9 | A4 A5, A10 A15 A3 A3 |
| A9 SERIES 2121 2120A 2104A 2044A A9 SERIES 2036 | 1 through 10 1 through 11 1 through 12 1 through 13 1 through 14 | A9 A2, A3, W7, W8 A3, A4, A6, and A12 A13 A9 |
| 2032A 2028A 2024A 2012A 2008A 1928A | 1 through 15 1 through 16 1 through 17 1 through 18 1 through 19 1 through 20 | A9 A10, A11, and A12 A1, A5, A10, A11, and A12 A1 A3 and A9 A1, A2, and A13 |

CHANGE 1 (Serial Prefix No. 2224A)

Section VI, Table 6-6, A12 Replaceable Parts (Opt. 040):
Change ckt bd A12 (05335-60012) to SERIES 2224.
Change A12R112 & R113 Reference Designations to A12R47 & R67, respectively.

Section VIII, A12 Schematic Diagram:

Change A12 (05335-60012) diagram to SERIES 2224.

Delete resistor R112 between K2 pins 6 and 8.
Add 51.1K resistor R47 between K2 pins 6 and 7.
Delete resistor R113 between K7 pin 2 and the junction of resistors R68 and R72.
Add 51.1K resistor R67 between K7 pin 3 and junction of R68 and R72.

CHANGE 2 (Serial Prefix No. 2220A)

Section VI, Table 6-2, Assy A2, A3, and A5-A7 Replaceable Parts:

Change ckt bd A2 (05335-60002) to SERIES 2134.
Change A2J1 & J2 to Part No. 1200-0617; CD=2.
Socket 1200-0614 is recommended for replacement.
Add 1200-0617; CD=2; QTY=2; LOCK INLINE 18-PIN.

Change ckt bd A3 (05335-60003) to SERIES 2152.
Change A3J2 & J5 to Part No. 1200-0617; CD=2.
Socket 1200-0614 is recommended for replacement.
Add 1200-0617; CD=2; QTY=2; LOCK INLINE 18-PIN.

Change ckt bd A5 (05335-60005) to SERIES 2202.
Change A5XDS1-DS14 to 1200-0679; CD=6; QTY=14;
SOCKET-IC 14-CONT DIP-SLDR.
Socket 1200-0679 is recommended to replace XDS1-14.

Change ckt bd A6 (05335-61006) to SERIES 2120.
Change A6J7 to Part No. 1200-0519; CD=3.
Socket 1200-0482 is recommended to replace A6J7.
Add 1200-0523; CD=9; LOCK DUAL INLINE 16-PIN.

Change ckt bd A7 (05335-60007) to SERIES 1928.
Change A7J1 & J2 to Part No. 1200-0519; CD=3.
Add 1200-0523; CD=9; QTY=2; LOCK INLINE 16-PIN.
Socket 1200-0482 is recommended to replace J1-J2.
Change A7XU1 to Part No. 1200-0552; CD=4.
Socket 1200-0682 is recommended to replace A7XU1.

Section VI, Table 6-6, A11 and A12 Replaceable Parts:
Change ckt bd A11 (05335-60011) to SERIES 2220.
Change A11J1 & J2 to Part No. 1200-0617; CD=2.
Socket 1200-0614 is recommended to replace A11J1-J2.
Add 1200-0617; CD=2; QTY=2; LOCK INLINE 18-PIN.

Change ckt bd A12 (05335-60012) to SERIES 2120.
Change A12J2 & J7 to Part No. 1200-0617; CD=2.
Socket 1200-0614 is recommended to replace A12J2-J7.
Add 1200-0617; CD=2; QTY=2; LOCK INLINE 18-PIN.

Section VIII, A2, A3, A5-A7, A11, & A12 Schematic:
Change A2 (05335-60002) diagram to SERIES 2134.
Change A3 (05335-60003) diagram to SERIES 2152.
Change A5 (05335-60005) diagram to SERIES 2202.
Change A6 (05335-61006) diagram to SERIES 2120.
Change A7 (05335-60007) diagram to SERIES 1928.
Change A11 (05335-60011) diagram to SERIES 2220.
Change A12 (05335-60012) diagram to SERIES 2120.

CHANGE 3. (Serial Prefix No. 2216A)

Section VI, Table 6-2, A4 Replaceable Parts:

Change ckt bd A4 (05335-60004) to SERIES 2216.
Change A4J1 to Part No. 1200-0519; CD=3.
Use Socket 1200-0482 to replace A4J1.
Add 1200-0523; CD=9; LOCK DUAL INLINE 16-PIN.

Section VI, Table 6-6, A11 Replaceable Parts (Opt. 040):
Change ckt bd A11 (05335-60011) to SERIES 2028.
Change A11XU21 & XU23 to Part No. 1200-0423; CD=8.
Use Socket 1200-0482 to replace A11XU21-XU23.
Add 1200-0523; CD=9; LOCK DUAL INLINE 16-PIN.

Section VIII, A4 and A11 Schematic Diagrams:
Change A4 (05335-60004) diagram to SERIES 2216.
Change A11 (05335-60011) diagram to SERIES 2028.

CHANGE 4. (Serial Prefix No. 2208A)

Table 6-2, A4 Replaceable Parts:

Change ckt bd A4 (05335-60004) to SERIES 2208.
Change A4XU22 & XU23 to Part No. 1200-0522; CD=8.
Delete 1200-0825 20-pin sockets for A4XU7 & XU27.

Section VIII, A4 Schematic Diagram:

Change A4 (05335-60004) diagram to SERIES 2208.

CHANGE 5. (Serial Prefix No. 2202A02446 or above)

Section VI, Table 6-2, A4 Replaceable Parts:

Change ckt bd A4 (05335-60004) to SERIES 2120.
Change A4U16 & U24 to Part No. 1820-2075; CD=4;
QTY=2; TTL 74LS245 XCR.
The 1820-2866 745C245 CMOS is recommended for
replacement of A4U16 & U24 in all instruments.
Delete 1200-0825 20-pin sockets A4XU16 & XU24.

Section VIII, A4 Schematic Diagram:

Change A4 (05335-60004) diagram to SERIES 2120.

CHANGE 6. (Serial No. 2202A02445 and below)

Section VI, Table 6-2, A5 Replaceable Parts:

Change ckt bd A5 (05335-60005) to SERIES 2044.
Change A5DS15-DS48 to Part No. 1990-0670;
CD=0; QTY=34; LED-VISIBLE YELLOW MINI.

Section VIII, A5 Schematic Diagram:

Change A5 (05335-60005) diagram to SERIES 2044.

Section VI, Table 6-6, A10 Replaceable Parts:

Change ckt bd A10 (05335-60010) to SERIES 2028.
Change A10DS1-DS12 to Part No. 1990-0670;
CD=0; QTY=12; LED-VISIBLE YELLOW MINI.

Section VIII, A10 Schematic Diagram:

Change A10 (05335-60010) diagram to SERIES 2028.

CHANGE 7. (Serial Prefix No. 2152A)

Section VI, A15 Replaceable Parts (Option 010)

Delete 10811-60111 10 MHz Oven Oscillator.
Delete 10811-90002 Operating and Service Manual.
The 10544-60011 and 10811-60111 oscillators are
directly interchangeable. The Part No. 10811-60111
oscillator can be used to add or replace A15 in any
instrument with a Serial Number Prefix below 2202A.

CHANGE 8. (Serial Prefix No. 2140A)

Section VI, Table 6-2, A3 Replaceable Parts:

Change ckt bd A3 (05335-60003) to SERIES 2140
Change A3R99-R101 to Part No. 2100-3359; CD=4.
Change A3S2-S10 & S12 to Part No. 3101-2124.
The 3101-2498 switches have gold contacts and are
recommended for replacement in all instruments.

Section VIII, A3 Schematic Diagram:

Change A3 (05335-60003) diagram to SERIES 2140.

CHANGE 9. (Serial Prefix No. 2134A)

Section VI, Table 6-2, A3 Replaceable Parts:

Change ckt bd A3 (05335-60003) to SERIES 2134.
Change A3C27 & C35 to Part No. 0160-3878.
The 0160-4040 capacitor is recommended replacement
for improved reliability.

Section VIII, A3 Schematic Diagram:

Change A3 (05335-60003) diagram to SERIES 2134.

CHANGE 10. (A9 option bd SERIES 2036)

Section VI, Table 6-5, A9 Replaceable Parts

Change ckt bd A9 (05335-60009) to SERIES 2036.

The instrument Serial Prefix Number does not change with this change in circuit board A9.

Change A9R14 to 0698-7233; CD=4; RESISTOR 750 1% .05W F TC=0±100.

Change A9R15 to 0698-7234; CD=5; RESISTOR 825 1% .05W F TC=0±100.

The higher resistor values, shown in Table 6-5 are recommended for replacement.

Section VIII, A9 Schematic Diagram:

Change A9 (05335-60009) diagram to SERIES 2036.

Change R14 value from 1.62K to 750 ohms.

Change R15 value from 1.78K to 825 ohms.

CHANGE 11. (Serial Prefix No. 2120A)

Section VI, Table 6-2, A2 Replaceable Parts:

Change ckt bd A2 (05335-60002) to SERIES 2008.

Change A2R32 & R51 to 0698-7242; CD=5;

RESISTOR 1.78K 1% .05W F TC=0±100.

Add A2CR6 & CR7; 1901-0050; CD=3; DIODE-SWITCHING 80V 200MA 2NS.

Delete A2W1 & A2W2 wire jumpers (8159-0005).

Section VI, Table 6-2, A3 Replaceable Parts:

Change ckt bd A3 (05335-60003) to SERIES 2120.

Change A3C4, 5, 7, 8, 51, 52, 53, & C57 to 0160-4931;

CD=4; CAP.-FXD .47UF MATCHED SETS OF TWO; C4-C7, C5-C8, C51-C52, & C53-C57.

Add A3R7*, R8*, R80*, & R81*; 0698-7288; CD=9;

RESISTOR 147K 1% .05W F TC=0±100.

Delete A3Q9 & A3Q10 transistors (1854-0686).

Delete resistors A3R99 through A3R106.

NOTE — Resistors A3R7*, R8*, R80*, and R81* require selected components in the peak detector circuit.

A procedure for selecting the resistors is given in paragraphs 7-8 through 7-14.

Section VI, Table 6-3, Replaceable Electrical Parts:

Change W7 and W8 to 05335-60103; CD=0; QTY=2; CABLE ASSY-COAX 75 OHM (SERIAL PREFIX 2120A OR BELOW). If instrument has Option 040, W7 and W8 must be 50 ohm (Part No. 05335-60112) cables.

Section VIII, A2 Schematic Diagram.

Change 05335-60002 (A2) to SERIES 2008.

Change A2R32 & R51 to 1780 ohms.

Replace wire jumpers A2W1 & A2W2 with diodes A2CR6 & A2CR7, respectively.

Add A2CR6 in series with channel B input.

Connect anode to junction of J4 and R33;

cathode to junction of R32 and U7(12,13).

Add A2CR7 in series with channel B input.

Connect anode to junction of J3 and R39;

cathode to junction of R32, U11(7), & U7(3).

Section VIII A3 Schematic Diagram:

Change A3 (05335-60003) diagram to SERIES 2120.

Change A3C4,C5,C7,C8,C51,C52,C53, & C57 to .47U

Add 147K resistors R7*, R8*, R80*, & R81*.

Connect R7* in parallel with diode CR1, R8* in

parallel with CR2, R80* in parallel with CR28,

and R81* in parallel with CR29.

Delete 2M controls R99 through R102 and replace each with a wire jumper.

Delete R105, R106, & Q10 in output "BO" line to J1 and connect U2(19) directly to J1.

Add "75 OHM" to W8 cable connected to J1.

Delete R103, R104, & Q9 in output "AO" line to J6 and connect U5(19) directly to J6.

Add "75 OHM" to W7 cable connected to J6.

NOTE

The A2 Series 2008 and A3 Series 2120 circuit boards in instruments with Serial Prefix 2120A, or below, cannot be directly interchanged with Series 2134, or above, circuit boards. Interconnect cables W7 and W8, between A2 and A3, must be 75-ohms in instruments with a Serial Prefix of 2120A or below.

CHANGE 12. (Serial Prefix No. 2104A)

Section VI, Table 6-2, Assemblies A3,A4,A6,&A12 Replaceable Parts:

Change ckt bd A3 (05335-60003) to SERIES 1928.

Change A3R16 & R74 to 0698-3444; CD=1; RESISTOR 316 ohms 1% .125W TC=0±100.

Change ckt bd A4 (05335-60004) to SERIES 1928.

Add A4R10; 0757-0280; CD=3; RESISTOR 1.00K 1% .125W F. TC=0±100.

Change A4R17 to 0698-7260; CD=7; RESISTOR 10.0K 1% .05W F TC=0--100.

Change A4R36 & R37 to 0698-3431; CD=8; RESISTOR 28.7 ohms 1% .125W F TC=0±100.

Delete CR11 diode 1901-0535.

Delete R55 resistor 0698-7250.

Change A6 ckt bd to Part No. 05335-60006.

Replace the portion of Table 6-2 listing replaceable parts for A4 Part No. 05335-61006 with the parts for A6 Part No. 05335-60006 in Table 7-2.

Delete MP4 Part No. 05335-00014 rear panel from Table 6-3 "Miscellaneous Chassis Parts". The 05335-60006 assembly has slide switches for A6S1 and A6S2 which required a rear panel with slots for the switch handles.

Change ckt bd A12 (05335-60012) to SERIES 2028.

Change A12R30 & R90 to 0698-3444; CD=1;

RESISTOR 316 ohms 1% .125W TC=0±100.

Section VIII A3, A4, A6, and A12 Schematic Diagrams:

Change A3 (05335-60003) diagram to SERIES 1928.

Replace schematic diagram and component locator

for A6 (HP Part No. 05335-61006) with schematic diagram and component locator in Figures 7-1 and 7-2 for A6 Part No. 05335-60006 (SERIES 1928).

Change A4 (05335-60004) diagram to SERIES 1928.

Delete diode CR11 and resistor R55.

Replace CR11 with a wire jumper.

Change the value of R17 to 10K ohms.

Add R10 1000 ohm resistor between U2A(8,11,12) and the junction of C13, R17, and CR3.

Change A12 (05335-60012) diagram to SERIES 2028.

Change A12R30 & R90 to 316 ohms.

CHANGE 13. (Serial Prefix No. 2044A)

Section VI, Table 6-2, A13 Replaceable Parts:
Change A13 LINE MODULE-FILTERED part number from 0960-0443 to number 0969-0448 as shown by the diagram in Figure 7-3. The instrument Serial Prefix Number becomes 2044A.

Section VIII, A1/A13 Schematic Diagram:
Change part number for A13 to 0969-0448 and mark A13 diagram to show differences shown in Figure 7-2.

CHANGE 14. (A9 SERIES 2036)

Section VI, Table 6-5, A9 Replaceable Parts:
Change ckt bd A9 (05335-60009) to SERIES 2012.
Delete A9C28 .01UF capacitor (Part No. 0160-3879).

Section VIII, A9 Schematic Diagram:
Change A9 (05335-60009) diagram to SERIES 2012.
Delete .01UF capacitor C28.

CHANGE 15. (Serial Prefix No. 2032A)

All instruments with Option 030 and a Serial Prefix Number of 2032A have SERIES 2036 circuit boards for A9. The following instruments with Option 030 also have SERIES 2036 circuit boards.

2012A00191, 00192, 00206, and 00211.
2028A00241, 00247, and 00248.
2024A00217, 00219, 00221-00225, 00227, 00230, 00233, and 00235.
2028A00251, 00253, 00256-00259, 00265, 00266, 00268-00270, 00277, 00279, 00282, 00284, 00287, 00294, and 00300.

All other instruments with with Option 030 and serial numbers below the above instruments have a SERIES 2012 board for A9.

CHANGE 16. (Serial Prefix No. 2028A)

Option 040 for Programmable Input Amplifiers first introduced in instruments with Serial Prefix Number 2028A. Circuit board A10 (HP Part No. 05335-60010) is added. Circuit board A2 is replaced by A11 (HP Part No. 05335-60011), and A3 is replaced by circuit board A12 (HP Part No. 05335-60012). These circuit boards require 50-ohm (HP Part No. 05335-60112) cable assemblies for W7 and W8.

Circuit board A10 has two more keys (A/B FILTER) which necessitates a new HP Part No. 05335-00013 (MP33) front panel.

CHANGE 17. (Serial Prefix No. 2024A)

Section VI, Table 6-2, A1 and A5 Replaceable Parts:
Change ckt bd A1 (05335-60001) to SERIES 2024.
Change A1CR1 to 1902-0940; CD=2; DIODE-ZNR 1N5339B 5.6V 5% PD=5W.
Use the 1902-0522 (6V) diode to replace A1CR1.

Change ckt bd A5 (05335-60005) to SERIES 1928.
Delete 6.81K resistor A5R5 (0757-0439).

Section VI, Table 6-3, Misc. Chassis Parts:
Delete MP33 part number 05335-00013 front panel.

Section VI, Table 6-6, Option 040 Replaceable Parts:
Delete the entire contents of Table 6-6.

Section VIII, A1 and A5 Schematic Diagram:
Change A1 (05335-60001) diagram to SERIES 2024. No other schematic change is required.
Change A5 (05335-60005) diagram to SERIES 1928.
Delete 6810 ohm resistor A5R5.

CHANGE 18. (Serial Prefix 2012A)

Section V. Power Supply Adjustment Procedure:
Delete Paragraphs 5-12.e. and 5-12.f. Instruments with Serial Prefix No. 2012A or below do not have an adjustment for the 15.7V supply.

Section VI, Table 6-2, A1 Replaceable Parts:
Change ckt bd A1 (05335-60001) to SERIES 1928.
Add A1CR5; 1901-0050; CD=3; DIODE-SWITCHING 80V 200MA 20NS DO-35.
Delete A1CR12 switching diode (1901-0050).
Delete 50-ohm trimmer resistor A1R15 (2100-3383).
Delete 825-ohm fixed resistor A1R16 (0757-0421).
Delete A1MP1 Heatsink Part No. 05335-00005.

Section VI, Table 6-3, Misc. Chassis Parts:
Add 05335-00005; CD=5; HEATSINK.
Add HP Part No. 5001-0439; CD=2; SIDE TRIM.

Section VIII, A1 Schematic Diagram:
Change 05335-60001 to SERIES 1928.
Replace A1CR12 with a wire jumper.
Delete 825 ohm resistor A1R16.
Replace 50-ohm trimmer resistor A1R15 with added diode A1CR5. Connect CR5 anode to U6(2) and cathode to circuit board common with CR2 anode.

CHANGE 19. (Serial Prefix No. 2008A)

Section VI, Table 6-2, A3 Replaceable Parts:
Change ckt bd A3 (05335-60003) to SERIES 2008.
Change A3C3* and A3C7* to 0160-4493; CD=3; CAPACITOR-FXD 27PF 5% 200VDCW CERAMIC TC=0±30. The 0160-3875 capacitor (22 pF) is a preferred replacement.

Section VI, Table 6-5, A9 Replaceable Parts:
Change ckt bd A9 (05335-60009) to SERIES 1928.
Change A9L2 & L4 to 9100-2272; CD=5; INDUCTOR RFC-MLD 47UH 10%.

Section VIII, A3 and A9 Schematic Diagrams:
Change A3 (05335-60003) schematic to SERIES 2008.
Change A3C23* & A3C7* (near X10 ATTN) to 27 pF.
Change A9 (05335-60009) Schematic to SERIES 1928
Change values of A9L2 & L4 to 0.47UH.

CHANGE 20. (Serial Prefix No. 1928A)

Section VI, A2 and A13 Table of Replaceable Parts:
Change ckt bd A2 (05335-60002) to SERIES 1928.
Delete 50 ohm trimmer resistors A2R65 and R66 (Part No. 2100-3383).
Change A2R47 & R50 to 0757-0401; CD=0; RESISTOR-FXD 100 1% .125W F TC=0±100.
Change A13 LINE MODULE-FILTERED to Part No. 0960-0433. The schematic diagram for this module is shown with the schematic diagram for A1 in Section VIII of this manual.

Section VIII, A2 Schematic Diagram:
Change A2 (05335-60002) diagram to SERIES 1928.
Delete A2R65 & R66 trimmer resistors.
Change the value of A2R47 & R50 to 100 ohms.
Connect the bottom end of A2R47 & R50 to circuit board common.

Table 7-2. A6 (05335-60006) Series 1928 Replaceable Parts

| Reference Designation | HP Part Number | C D | Qty | Description | Mfr Code | Mfr Part Number |
|-----------------------|----------------|-----|-----|---|----------|------------------|
| A6 | 05335-60006 | 2 | 1 | BOARD ASSEMBLY-REAR | 28480 | 05335-60006 |
| A6C1* | 0160-4557 | 0 | 5 | CAPACITOR-FXD .1UF +-20% 50VDC CER | 16299 | CAC04X7R104M050A |
| A6C2 | 0160-0210 | 6 | 3 | CAPACITOR-FXD 3.3UF +-20% 15VDC TA | 56289 | 1500335X0015A2 |
| A6C3 | 0160-4554 | 7 | 5 | CAPACITOR-FXD .01UF +-20% 50VDC CER | 28480 | 0160-4554 |
| A6C4 | 0160-0210 | 6 | 6 | CAPACITOR-FXD 3.3UF +-20% 15VDC TA | 56289 | 1500335X0015A2 |
| A6C5 | 0160-4557 | 0 | 0 | CAPACITOR-FXD .1UF +-20% 50VDC CER | 16299 | CAC04X7R104M050A |
| A6C6 | 0160-0210 | 6 | 0 | CAPACITOR-FXD 3.3UF +-20% 15VDC TA | 56289 | 1500335X0015A2 |
| A6C7 | 0160-4557 | 0 | 0 | CAPACITOR-FXD .1UF +-20% 50VDC CER | 16299 | CAC04X7R104M050A |
| A6C8 | 0160-3046 | 0 | 4 | CAPACITOR-FXD 250PF +-1% 100VDC MICA | 28480 | 0160-3046 |
| A6C9 | 0160-4554 | 7 | 0 | CAPACITOR-FXD .01UF +-20% 50VDC CER | 28480 | 0160-4554 |
| A6C10 | 0160-3874 | 2 | 3 | CAPACITOR-FXD 10PF +-1.5PF 200VDC CER | 28480 | 0160-3874 |
| A6C11 | 0160-3874 | 2 | 0 | CAPACITOR-FXD 10PF +-1.5PF 200VDC CER | 28480 | 0160-3874 |
| A6C11 | 0160-3874 | 2 | 0 | CAPACITOR-FXD 10PF +-1.5PF 200VDC CER | 28480 | 0160-3874 |
| A6C12 | 0160-4554 | 7 | 0 | CAPACITOR-FXD .01UF +-20% 50VDC CER | 28480 | 0160-4554 |
| A6C13 | 0160-3046 | 0 | 0 | CAPACITOR-FXD 250PF +-1% 100VDC MICA | 28480 | 0160-3046 |
| A6C14 | 0160-3046 | 0 | 0 | CAPACITOR-FXD 250PF +-1% 100VDC MICA | 28480 | 0160-3046 |
| A6C15 | 0160-4554 | 7 | 0 | CAPACITOR-FXD .01UF +-20% 50VDC CER | 28480 | 0160-4554 |
| A6C16 | 0160-4554 | 7 | 0 | CAPACITOR-FXD .01UF +-20% 50VDC CER | 28480 | 0160-4554 |
| A6C17 | 0160-4557 | 0 | 0 | CAPACITOR-FXD .1UF +-20% 50VDC CER | 16299 | CAC04X7R104M050A |
| A6C18 | 0160-4557 | 0 | 0 | CAPACITOR-FXD .1UF +-20% 50VDC CER | 16299 | CAC04X7R104M050A |
| A6C19 | 0160-3046 | 0 | 0 | CAPACITOR-FXD 250PF +-1% 100VDC MICA | 28480 | 0160-3046 |
| A6C20 | 0160-0682 | 4 | 1 | CAPACITOR-FXD 3.3PF +-1.5PF 200VDC CER | 28480 | 0160-0682 |
| A6CR1 | 1901-0050 | 3 | 5 | DIODE-SWITCHING 80V 200MA 2NS DO-35 | 28480 | 1901-0050 |
| A6CR2 | 1901-0535 | 9 | 1 | DIODE-SM SIG SCHOTTKY | 28480 | 1901-0535 |
| A6CR3 | 1901-0050 | 3 | 0 | DIODE SWITCHING 80V 200MA 2NS DO-35 | 28480 | 1901-0050 |
| A6CR4 | 1901-0050 | 3 | 0 | DIODE-SWITCHING 80V 200MA 2NS DO-35 | 28480 | 1901-0050 |
| A6CR5 | 1901-0050 | 3 | 0 | DIODE-SWITCHING 80V 200MA 2NS DO-35 | 28480 | 1901-0050 |
| A6CR6 | 1901-0050 | 3 | 0 | DIODE-SWITCHING 80V 200MA 2NS DO-35 | 28480 | 1901-0050 |
| A6J1 | 1250-1453 | 1 | 6 | CONNECTOR-RF BNC FEM SGL-HOLE-RR 50-OHM | 28480 | 1250-1453 |
| A6J2 | 1250-1453 | 1 | 0 | CONNECTOR-RF BNC FEM SGL-HOLE-RR 50-OHM | 28480 | 1250-1453 |
| A6J3 | 1250-1453 | 1 | 0 | CONNECTOR-RF BNC FEM SGL-HOLE-RR 50-OHM | 28480 | 1250-1453 |
| A6J4 | 1250-1453 | 1 | 0 | CONNECTOR-RF BNC FEM SGL-HOLE-RR 50-OHM | 28480 | 1250-1453 |
| A6J5 | 1250-1453 | 1 | 0 | CONNECTOR-RF BNC FEM SGL-HOLE-RR 50-OHM | 28480 | 1250-1453 |
| A6J6 | 1250-1453 | 1 | 0 | CONNECTOR-RF BNC FEM SGL-HOLE-RR 50-OHM | 28480 | 1250-1453 |
| A6J7 | 1200-0519 | 3 | 1 | SOCKET-IC 16-CONT DIP-SLDR | 28480 | 1200-0519 |
| A6L1 | 9100-0348 | 2 | 3 | INDUCTOR RF-CH-MLD 1UH 1% .166DX,365A G | 28480 | 9100-0348 |
| A6L2 | 9100-0348 | 2 | 0 | INDUCTOR RF-CH-MLD 1UH 1% .166DX,365A G | 28480 | 9100-0348 |
| A6L3 | 9100-0348 | 2 | 0 | INDUCTOR RF-CH-MLD 1UH 1% .166DX,365A G | 28480 | 9100-0348 |
| A6Q1 | 1854-0215 | 1 | 6 | TRANSISTOR NPN SI PD=350MW FT=300MHZ | 04713 | 2N3904 |
| A6Q2 | 1854-0215 | 1 | 0 | TRANSISTOR NPN SI PD=350MW FT=300MHZ | 04713 | 2N3904 |
| A6Q3 | 1854-0215 | 1 | 0 | TRANSISTOR NPN SI PD=350MW FT=300MHZ | 04713 | 2N3904 |
| A6Q4 | 1853-0036 | 2 | 1 | TRANSISTOR PNP SI PD=310MW FT=250MHZ | 28480 | 1853-0036 |
| A6Q5 | 1854-0215 | 1 | 0 | TRANSISTOR NPN SI PD=350MW FT=300MHZ | 04713 | 2N3904 |
| A6Q6 | 1854-0215 | 1 | 0 | TRANSISTOR NPN SI PD=350MW FT=300MHZ | 04713 | 2N3904 |
| A6Q7 | 1854-0215 | 1 | 0 | TRANSISTOR NPN SI PD=350MW FT=300MHZ | 04713 | 2N3904 |
| A6R1 | 0757-0401 | 0 | 1 | RESISTOR 100 1% .125W F TC=0+-100 | 24546 | C4-1/8-T0-101-F |
| A6R2 | 0698-3162 | 0 | 1 | RESISTOR 46.4K 1% .125W F TC=0+-100 | 24546 | C4-1/8-T0-4642-F |
| A6R3 | 0757-0405 | 4 | 1 | RESISTOR 162 1% .125W F TC=0+-100 | 24546 | C4-1/8-T0-162P-F |
| A6R4 | 0757-0280 | 3 | 4 | RESISTOR 1K 1% .125W F TC=0+-100 | 24546 | C4-1/8-T0-1001-F |
| A6R5 | 0698-3155 | 1 | 1 | RESISTOR 4.64K 1% .125W F TC=0+-100 | 24546 | C4-1/8-T0-4641-F |
| A6R6 | 1010-0367 | 2 | 1 | NETWORK-RES 6-SIP4.7K OHM X 5 | 01121 | 286A472 |
| A6R7 | 0698-0084 | 9 | 1 | RESISTOR 2.15K 1% .125W F TC=0+-100 | 24546 | C4-1/8-T0-2151-F |
| A6R8 | | | | NOT ASSIGNED | | |
| A6R9 | 0698-3444 | 1 | 1 | RESISTOR 316 1% .125W F TC=0+-100 | 24546 | C4-1/8-T0-316P-F |
| A6R10 | 0757-0280 | 3 | 0 | RESISTOR 1K 1% .125W F TC=0+-100 | 24546 | C4-1/8-T0-1001-F |
| A6R11 | 0757-1093 | 8 | 2 | RESISTOR 3K 1% .125W F TC=0+-100 | 24546 | C4-1/8-T0-3001-F |
| A6R12 | 0757-1094 | 9 | 1 | RESISTOR 1.47K 1% .125W F TC=0+-100 | 24546 | C4-1/8-T0-1471-F |
| A6R13 | 0757-0442 | 9 | 2 | RESISTOR 10K 1% .125W F TC=0+-100 | 24546 | C4-1/8-T0-1002-F |
| A6R14 | 0757-0178 | 8 | 1 | RESISTOR 100 1% .125W F TC=0+-100 | 24546 | C5-1/4-T0-101-F |
| A6R15 | 0757-1093 | 8 | 0 | RESISTOR 3K 1% .125W F TC=0+-100 | 24546 | C4-1/8-T0-3001-F |
| A6R16 | 0757-0439 | 4 | 1 | RESISTOR 6.81K 1% .125W F TC=0+-100 | 24546 | C4-1/8-T0-6811-F |
| A6R17 | 0757-0442 | 9 | 0 | RESISTOR 10K 1% .125W F TC=0+-100 | 24546 | C4-1/8-T0-1002-F |
| A6R18 | 0757-0280 | 3 | 0 | RESISTOR 1K 1% .125W F TC=0+-100 | 24546 | C4-1/8-T0-1001-F |
| A6R19 | 0757-0280 | 3 | 0 | RESISTOR 1K 1% .125W F TC=0+-100 | 24546 | C4-1/8-T0-1001-F |
| A6S1 | 3101-2383 | 5 | 2 | SWITCH-SL DP3T HINTR .5A 125VAC PC | 28480 | 3101-2383 |
| A6S2 | 3101-2383 | 5 | 0 | SWITCH-SL DP3T HINTR .5A 125VAC PC | 28480 | 3101-2383 |

See introduction to this section for ordering information
*Indicates factory selected value

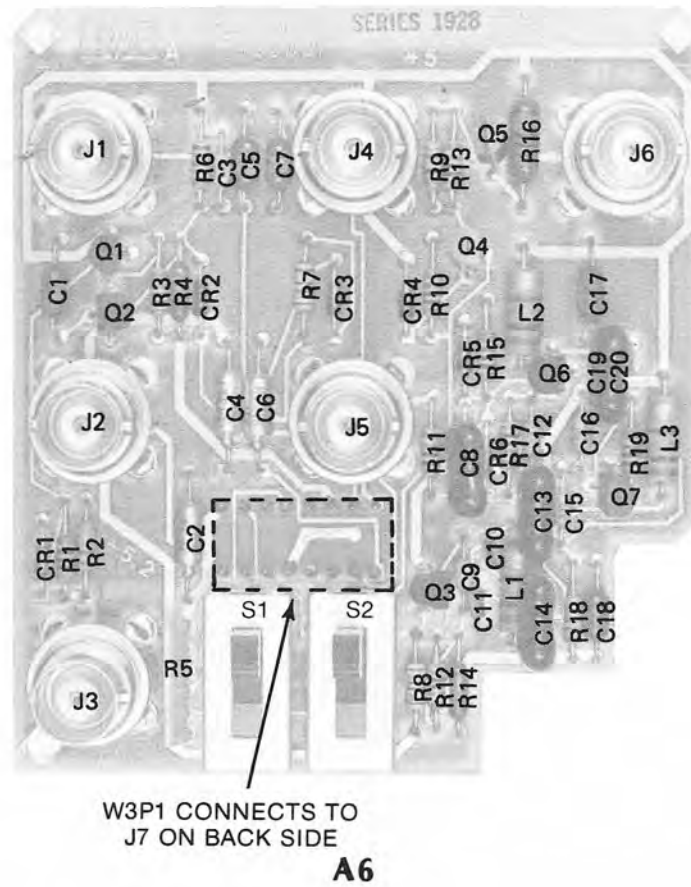
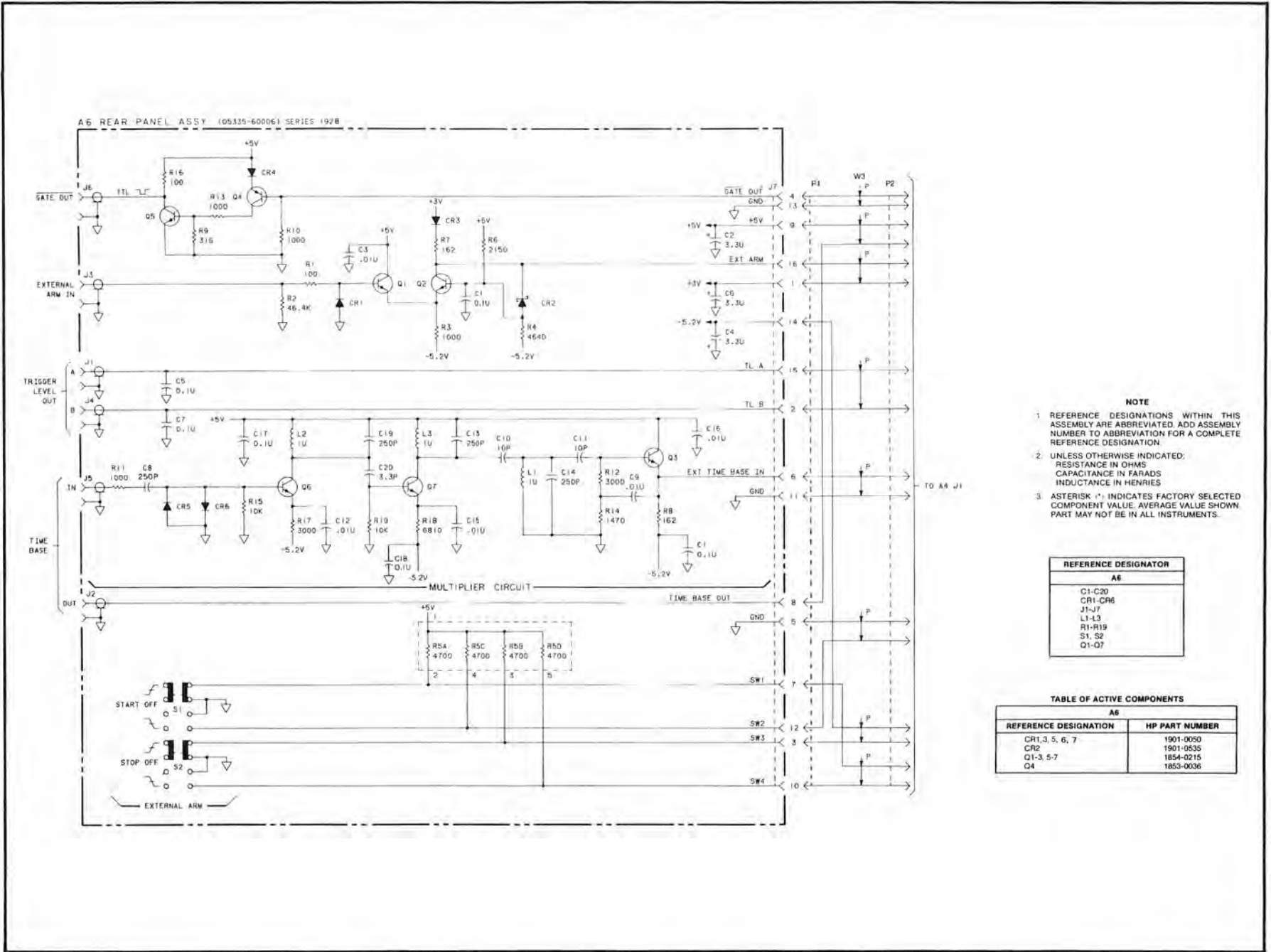

Figure 7-1. A6 (05335-60006) Series 1928 Component Locator

Figure 7-2. A6 (05335-60006) Series 1928 Schematic Diagram



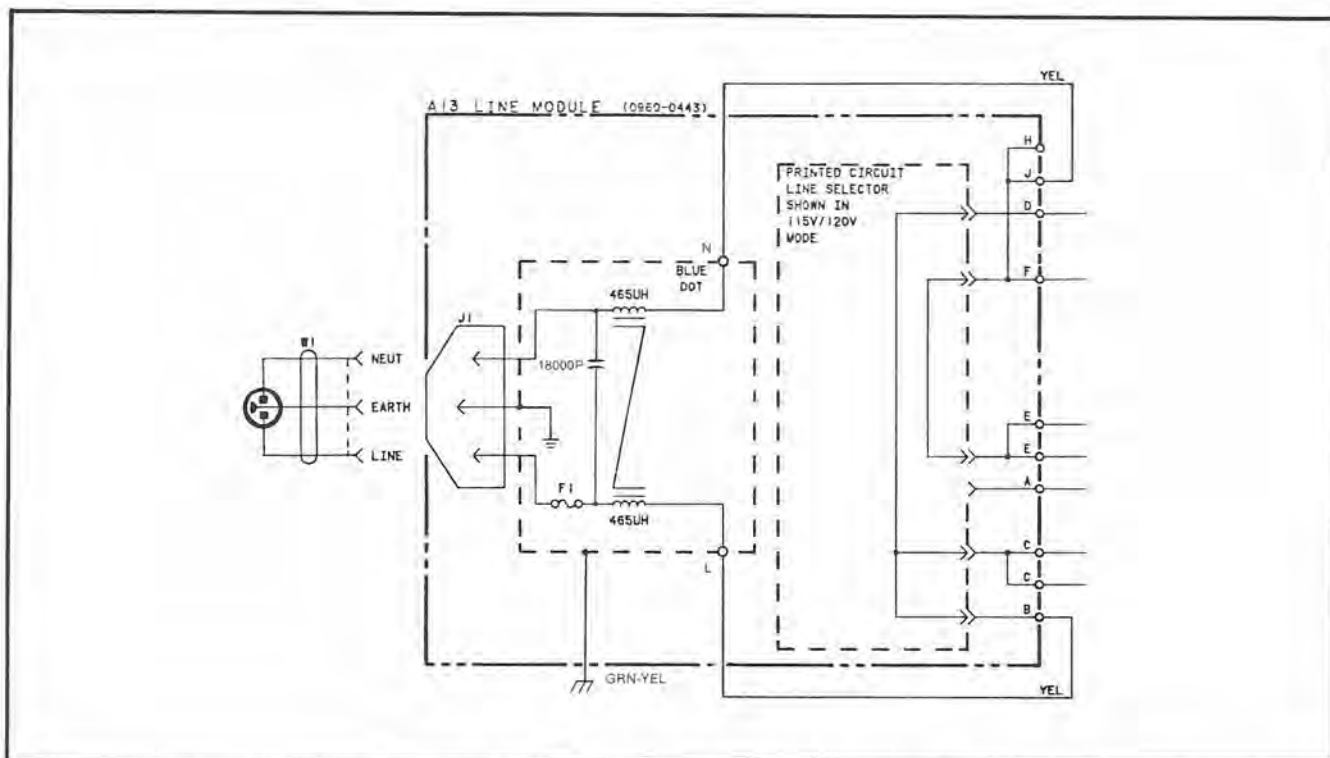

Figure 7-3. A13 Part Number 0960-0448 Schematic Diagram

7-8. SELECTED COMPONENTS (A3 SERIES 2120 OR BELOW)

7-9. Some parts in A3 (05335-60003) SERIES 2120 or below are selected during final checkout at the factory. Components are selected to provide optimum performance with other parts in the peak detector circuits as shown in Table 7-3.

7-10. Procedure For Selecting R7, R8, R80, or R81 in A3 Assembly

7-11. This procedure should be performed after changing any active component in the peak detector circuits or if a peak detector circuit malfunction is suspected. The resistors are located in the Channel A and Channel B peak-detector circuits; R7 and R8 in Channel B, R80 and R81 in Channel A.

7-12. To select any one or all four resistors connect a Function Generator with a 200 Hz square wave 500 mV p-p output to the 5335A Channel A input connector. Connect a 4½ digit voltmeter or digital multimeter, such as HP Model 3465A, to either end of the resistor shown in Table 7-4. To determine the correct input channel for the resistor to be selected, refer to the same table. Set 5335A front-panel controls as follows:

- INPUT (CHANNELS A and B)
- 1 Meg/50 ohm 50 ohm
- AC/DC DC (OUT)
- ATTN X1 (OUT)
- FUNCTION FREQ A
- AUTO TRIG ON (IN)
- COM A ON (IN)

Table 7-3. A3 Series 2120 or below Selected Components

| Resistor | Peak Detector | Diodes | Capacitors |
|----------|---------------------|------------------|------------|
| R7 | B Channel, Positive | CR1, CR4, CR5 | C4, C7 |
| R8 | B Channel, Negative | CR2, CR6, CR7 | C5, C8 |
| R80 | A Channel, Positive | CR24, CR25, CR28 | C51, C52 |
| R81 | A Channel, Negative | CR26, CR27, CR19 | C53, C57 |

Table 7-4. Selecting A3R7, R8, R80 or R81

| RESISTOR | VOLTAGE (mV) | VOLTMETER | | INPUT A OR B TRIGGER LEVEL |
|----------|-----------------|-----------|--------|-------------------------------|
| | | A3 (+) | A3 (-) | |
| R7 | +220 to +270 | R38 | COM | Fully cw |
| R8 | -220 to -270 | R38 | COM | Fully ccw out of PRESET |
| R80 | +220 to +270 | R54 | COM | Fully cw |
| R81 | -220 to -270 | R54 | COM | Fully ccw out of PRESET |

7-13. The digital voltmeter should display an indication of -220 mV to -270 mV. If the voltage is less than -220 mV (i.e., -210 mV), increase the resistor value as described in paragraphs 7-14.a. and 7-14.b. If the voltage is greater than -27 mV (i.e., -280 mV), decrease the resistor value as described in paragraphs 7-14.a. and 7-14.b.

7-14. After connecting the test equipment as described in paragraph 7-12, proceed as follows:

a. When selecting the optimum value for A3R7, A3R8, A3R80, or A3R81 use a 1%, .05W resistor (NOMINAL VALUE is 147K). The following are the values and HP part numbers for resistors which may be used.

| Value | HP Part No. |
|----------------|-------------|
| 75K | 0698-8615 |
| 100K | 0698-7284 |
| 147K* | 0698-7288 |
| OPEN | — |
| *NOMINAL VALUE | |

b. Select the nominal value, 147K. Measure the voltage at the test point described in Table 7-4 for each selected resistor. If the voltage is less than specified, increase the resistance by removing the resistor (A3R7, A3R8, A3R80, or A3R81), and leaving the circuit open ($\infty\Omega$). If the voltage is greater than specified, decrease the resistance first to 100K, and if necessary to 75K.

NOTE

If one of the four values listed does NOT bring the voltage within the specified range, DO NOT SELECT ANY OTHER VALUE. Proceed as described in steps c through e.

c. The circuit that contains each factory selected resistor has a set of matched diodes, and a set of matched capacitors. The matched sets for each circuit are shown in Table 7-3.

d. Measure the forward voltage drop across each diode of the matched set in the circuit for the resistor you are selecting. The voltage drop across each diode should match within less than 5 mV of each other.

If the voltages do not match within 5 mV, replace all three diodes in the set (order Part Number 05335-80003 for set of four matched diodes). If the voltage match, or if replacing the diodes does not correct the problem, then proceed to the next step.

e. Check the matched capacitors in the circuit containing the resistor to be selected. Verify that both capacitors in the set are .47 μ F at 1% tolerance. If they are not within the value specified, replace both capacitors. (Order Part Number 0160-4931 for matched set of two capacitors.)

SECTION VIII SERVICE

8-1. INTRODUCTION

8-2. This section provides service information and symbol descriptions, theory of operation, troubleshooting procedures, and schematic diagrams. The arrangement of the content of this section is described in detail below. Refer to the Table of Contents for specific page and paragraph numbers.

a. **SCHEMATIC DIAGRAM SYMBOLS AND REFERENCE DESIGNATIONS.** Describes the symbols used on schematic diagrams and reference designators used for parts, subassemblies and assemblies.

b. **IDENTIFICATION MARKINGS.** Describes the method used by Hewlett-Packard for identifying printed-circuit boards and assemblies.

c. **SAFETY CONSIDERATIONS.** Describes the safety considerations applicable during maintenance, adjustments, and repair.

d. **SAFETY SYMBOLS.** Lists and describes the safety symbols used on equipment and in manuals.

e. **RECOMMENDED TEST EQUIPMENT.** Refers to test equipment specified in *Table 1-4*.

f. **SERVICE AIDS.** Information provided to assist service personnel.

g. **FACTORY SELECTED COMPONENTS.** Lists procedures for replacement of parts whose values are selected at time of manufacture for optimum performance.

h. **LOGIC SYMBOLS.** Description of logic symbols used on schematics.

i. **THEORY OF OPERATION.** Presents the theory of operation for the 5335A in two levels.

1. First, the Overall Counter Operation is described using the simplified block diagram. This discussion introduces the major functional circuits and briefly explains their purpose and operation during normal measurements.
2. Second, the Block Diagram Description gives an in-depth explanation of each assembly; its function and operation with respect to measurement cycles. These paragraphs reference the detailed block diagram. Included in this discussion are descriptions of the multiple-register-counter (MRC), the microprocessor system, principles of the Interpolating technique, and the use of "peak-detectors" for triggering modes.

j. **TROUBLESHOOTING.** Provides the troubleshooting information for the HP 5335A in the following forms:

1. **DIAGNOSTICS**, which are built-in to the instrument, are used in a sequence illustrated in Block Diagrams. They serve to verify, by self-check, various functional subsections of the counter's circuitry. They can be selectively activated, in isolated loops, to allow on-line testing.
2. **SIGNATURE ANALYSIS**, which when integrated with the specified diagnostic routines, allows on-circuit troubleshooting to component level. All instructions, signatures, and physical Test-Points are provided.
3. **SCHEMATIC DIAGRAMS**, for all assemblies are provided at the end of this section. They are arranged in numerical order according to the assembly number.

8-3. SCHEMATIC DIAGRAM SYMBOLS AND REFERENCE DESIGNATORS

8-4. *Figure 8-1* shows the symbols used on the schematic diagrams. At the bottom of *Figure 8-1*, the system for reference designators, assemblies, and subassemblies is shown.

8-5. Reference Designations

8-6. Assemblies such as printed-circuits are assigned numbers in sequence, A1, A2, etc. As shown in *Figure 8-1*, subassemblies within an assembly are given a subordinate A number. For example, rectifier sub-assembly A1 has the complete designator of A25A1. For individual components, the complete designator is determined by adding the assembly number and subassembly number if any. For example, CR1 on the rectifier assembly is designated A25A1CR1.

8-7. IDENTIFICATION MARKINGS ON PRINTED-CIRCUIT BOARDS

8-8. HP printed-circuit boards (see *Figure 8-1*) have four identification numbers: an assembly part number, a series number, a revision letter, and a production code.

8-9. The assembly part number has 10 digits (such as 05335-60001) and is the primary identification. All assemblies with the same part number are inter-

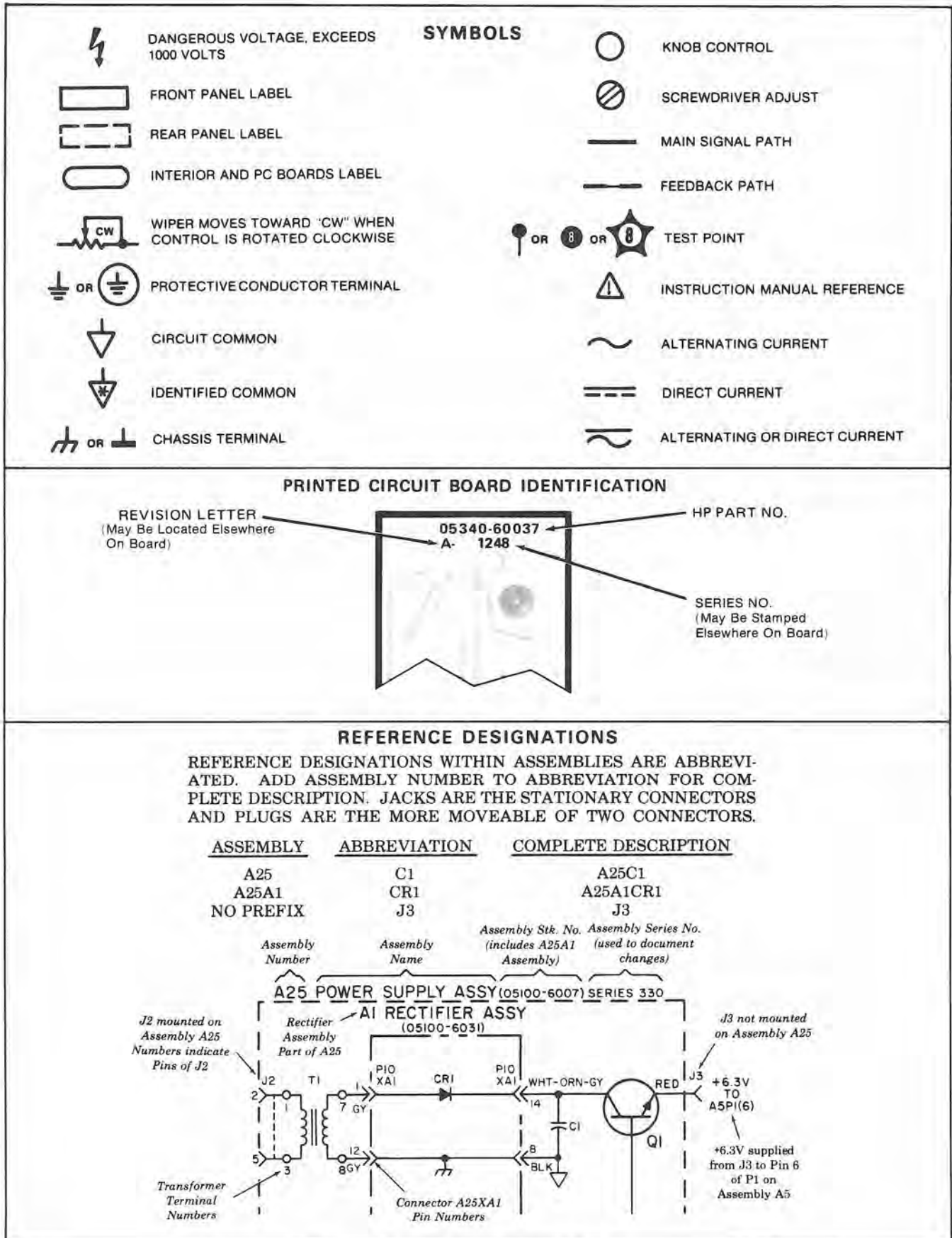

changeable. When a production change is made on an assembly that makes it incompatible with previous assemblies, a change in part number is required. The series number (such as 1936A) is used to document minor electrical changes. As changes are made, the series number is incremented. When replacement boards are ordered, you may receive a replacement with a different series number. If there is a difference between the series number marked on the board and the schematic in this manual, a minor electrical difference exists. If the number on the printed-circuit board is lower than that on the schematic, refer to Section VII for backdating information. If it is higher, refer to the looseleaf manual change sheets for this manual. If the manual change sheets are missing, contact your local Hewlett-Packard Sales and Support Office. See the listing on the back cover of this manual.

8-10. Revision letters (A, B, etc.) denote changes in printed-circuit layout. For example, if a capacitor type is changed (electrical value may remain the same) and requires different spacing for its leads, the printed-circuit board layout is changed and the revision letter is incremented to the next letter. When a revision letter changes the series number is also usually changed. The production code is the four-digit seven-segment number used for production purposes.

8-11. Assembly Identification

8-12. The assembly number, name, and Hewlett-Packard part number of 5335A assemblies are listed in *Table 8-1*.

Table 8-1. Assemblies and Major Parts Usage

| REF. DES. | PART NAME | HP PART NUMBER | OPTION 010 | OPTION 020 | OPTION 030 | OPTION 040 | STAND INST. |
|-----------|-----------------|----------------------------------|------------|------------|------------|------------|----------------|
| A1 | POWER SUPPLY | 05335-60001 | YES | YES | YES | YES | YES |
| A2 | AMPL. SUPPORT | 05335-60002 | YES | YES | YES | NO | YES |
| A3 | AMPL. BUFFER | 05335-60003 | YES | YES | YES | NO | YES |
| A4 | MAIN LOGIC | 05335-60004 | YES | YES | YES | YES | YES |
| A5 | DISPLAY | 05335-60005 | YES | YES | YES | YES | YES |
| A6 | REAR PANEL BD | 05335-61006 | YES | YES | YES | YES | YES |
| A7 | HP-IB CKT BD | 05335-60007 | YES | YES | YES | YES | YES |
| A8 | DVM CKT BD | 05335-60008 | NOTE | YES | NOTE | NOTE | NO |
| A9 | CHAN. "C" | 05335-60009 | NOTE | NOTE | YES | NOTE | NO |
| A10 | SW PANEL | 05335-60010 | NOTE | NOTE | NOTE | YES | NO |
| A11 | AMPL SUPPORT BD | 05335-60011 | YES | YES | YES | YES | NO |
| A12 | PROG.AMP/BUFFER | 05335-60012 | YES | YES | YES | YES | NO |
| A13 | POWER MODULE | 0960-0443 | YES | YES | YES | YES | YES |
| A14 | HP-IB CONN. | 05335-60014 | YES | YES | YES | YES | YES |
| A15 | 10 MHz OSC. | 10544-60511 OR 10811-60111 | YES | NOTE | NOTE | NOTE | NO |
| A16 | SERVICE AID BD | 05335-60013 | NO | NO | NO | NO | AVAIL ACCES |
| A17 | SHIELD BD | 05335-20203 | NOTE | NOTE | NOTE | YES | NO |
| MP1 | MAIN-PANEL STD. | 05335-00001 | YES | YES | YES | NO | YES |
| MP33 | MAIN-PANEL 040. | 05335-00013 | NOTE | NOTE | NOTE | YES | NO |
| MP2 | FILLER PANELS | 05335-00002 | 2 | 1 | 1 | 2 | 2 |
| MP34 | PANEL-FRONT 030 | 05335-00007 | NOTE | NOTE | YES | NOTE | NO |
| MP35 | PANEL-FRONT 020 | 05335-00008 | NOTE | YES | NOTE | NOTE | NO |

"NOTE" INDICATES COMPATIBLE ASSEMBLIES IN OPTION CIRCUIT BOARDS.
ALL OR ANY ONE OPTION CAN BE INSTALLED IN THE 5335A.

8-13. SAFETY CONSIDERATIONS

8-14. Although this instrument has been designed in accordance with international safety standards, this manual contains information, cautions, and warnings which must be followed to ensure safe operation and to retain the instrument in safe condition. Service and adjustments should be performed only by service-trained personnel.

WARNING

ALL PROTECTIVE EARTH TERMINALS, EXTENSION CORDS, AUTOTRANSFORMERS AND DEVICES CONNECTED TO THE INSTRUMENT SHOULD BE CONNECTED TO A PROTECTIVE EARTH GROUNDED SOCKET. ANY INTERRUPTION OF THE PROTECTIVE EARTH GROUNDING WILL CAUSE A POTENTIAL SHOCK HAZARD THAT COULD RESULT IN PERSONAL INJURY.

ONLY THE 250V FUSES WITH THE REQUIRED RATED CURRENT AND SPECIFIED TYPE SHOULD BE USED. DO NOT USE REPAIRED FUSES OR SHORT CIRCUITED FUSEHOLDERS. TO DO SO COULD CAUSE A SHOCK OR FIRE HAZARD.

8-15. Any adjustment, maintenance, and repair of the opened instrument under voltage should be avoided as much as possible and, when inevitable, should be carried out only by a skilled person who is aware of the hazard involved.

8-16. Capacitors inside the instrument may still be charged even if the instrument has been disconnected from its source of power.

WARNING

POWER IS ALWAYS PRESENT AT THE POWER SWITCH AND TRANSFORMER, AND UNREGULATED DC IS PRESENT WHENEVER THE LINE CORD IS ATTACHED. UNPLUGGING THE POWER CORD IS NECESSARY TO REMOVE ALL POWER FROM THE INSTRUMENT.

8-17. Make sure that only fuses with the required rated current and of the specified type (normal blow, time delay, etc.) are used for replacement. The use of repaired fuses and the short-circuiting of fuseholders must be avoided. Whenever it is likely that this protection has been impaired, the 5335A must be made inoperative and be secured against any unintended operation.

WARNING

THE SERVICE INFORMATION IS OFTEN USED WITH POWER SUPPLIED AND PROTECTIVE COVERS REMOVED FROM THE 5335A. ENERGY AVAILABLE AT MANY POINTS MAY, IF CONTACTED, RESULT IN PERSONAL INJURY.

CAUTION

Series pass transistor cases on rear panel have voltage on them and require insulators between them and the heatsink. Power supply damage is inevitable if transistor cases are shorted to the chassis.

8-18. Safety Symbols

8-19. The following safety symbols are used on equipment and in manuals:



Instruction manual symbol. The product will be marked with this symbol when it is necessary for the user to refer to the instruction manual in order to protect against damage to the instrument.



Indicates dangerous voltage (terminals fed from the interior by voltage exceeding 1000 volts must be so marked).

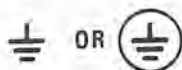

Protective conductor terminal. For protection against electrical shock in case of a fault. Used with field wiring terminals to indicate the terminal which must be connected to ground before operating equipment.



Low-noise or noiseless, clean ground (earth) terminal. Used for a signal common, as well as providing protection against electrical shock in case of a fault. A terminal marked with the symbol must be connected to ground in the manner described in the installation (operating) manual, and before operating the equipment.

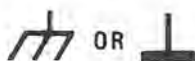

Frame and chassis terminal. A connection to the frame (chassis) of the equipment which normally includes all exposed metal structures.



Alternating current (power line).



Direct current (power line).



Alternating or direct current (power line).

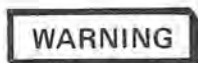

The WARNING signal denotes a hazard. It calls attention to a procedure, practice, or the like, which, if not correctly performed or adhered to, could result in personal injury.

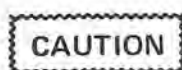

The CAUTION sign denotes a hazard. It calls attention to an operating procedure, practice, or the like, which is not correctly performed or adhered to, could result in damage to or destruction of part all of the product.

8-20. RECOMMENDED TEST EQUIPMENT

8-21. Test equipment and test equipment accessories required to maintain the 5335A are listed in *Table 1-4*. Equipment other than that listed may be used if it meets the listed critical specifications.

8-22. SERVICE AIDS

8-23. Pozidriv Screwdrivers

8-24. Many screws in the 5355A appear to be Phillips, but are not. To avoid damage to the screw slots, Pozidriv screwdrivers should be used.

8-25. Service Aids on Printed Circuit Boards

8-26. The servicing aids include test points, transistor and integrated circuit designations, adjustment call-outs, and assembly stock numbers.

8-27. How to Use the A16 Service Aid Board (05335-60013)

8-28. A 5335A Service Aid board is available that can facilitate the testing of the A4U28 Microprocessor address lines and the A4U22 and U23 ROMs data lines using the signature analysis technique. The part number for the Service Aid board is 05335-60013.

8-29. For convenience, when testing the A4U28 Microprocessor address lines, the Signature Analyzer can be connected to the A16 assembly directly (connections for CLOCK, START, STOP, and GROUND exist on the board). However, for testing the ROMs data lines the Signature Analyzer CLOCK Pod lead should be connected to the test pin marked "CK2" (located next to A4U23) when testing A4U23, and to "CK3" (located next to A4U22) when testing A4U22.

8-30. Complete instructions for use of the service aid board are given in the troubleshooting part of this section.

8-31. FACTORY SELECTED COMPONENTS

8-32. Some component values are selected at the time of final checkout at the factory. These values are selected to provide optimum compatibility with associated components and are identified on schematics and parts lists by an asterisk (*). The recommended procedure for replacing a factory-selected part is as follows:

- Refer to paragraphs 8-33 through 8-35 for test procedures required for selection of critical value parts.
- For factory selected components that are not listed in paragraphs 8-33 through 8-35, use the original value.
- After replacing parts, perform the test specified for the circuit in the performance and adjustment sections of this manual to verify correct operation.

8-33. Procedure to Select A3R83 on the Amplifier Buffer Assembly

| | |
|-----------------|-------------------|
| SELECTED VALUES | from 1.21K to 15K |
| NOMINAL VALUE | 2.7K |

- Connect the SIGNAL OUT from the function generator (HP 3325A) to the 5335A Channel A INPUT, and to the B INPUT on the oscilloscope (HP 1725A).
- Connect the A PROBE from the oscilloscope to resistor R39 on the A2 assembly (A2R39), between R39 and the anode of CR7.
- Set the 3325A (function generator):

| | |
|-----------|-----------------------|
| FREQUENCY | 1 kHz sine wave |
| AMPLITUDE | 100 mV p-p |
| DC OFFSET | 0 |

- Set the 1725A (oscilloscope):

| | |
|---------------------|--------------------|
| DISPLAY | X-Y FUNCTION |
| CHANNEL A VOLTS/DIV | to .05 |
| CHANNEL A INPUT | 1M ohm, DC |
| CHANNEL B VOLTS/DIV | to .01 |
| CHANNEL B INPUT | 50 ohm, DC |

- Set the 5335A:

| | |
|---------------------------|--------------------------|
| FUNCTION | TIME A-B |
| COM A | OFF (OUT) |
| AUTO TRIG | OFF (OUT) |
| EXT ARM ENABLE | OFF |
| INPUT (CHANNELS A and B): | |
| 1M/50 ohm | 1M (OUT) |
| AC/DC | DC (OUT) |
| X10 ATTN | OFF (OUT) |
| TRIGGER LEVELS | PRESET (fully CCW) |

- Set the oscilloscope for the X-Y mode, and calibrate by centering the dot at center screen.
- Adjust A3R96 (offset) to position the waveform at the center of the scope screen. Adjust A3R88 (hysteresis) for 18 to 20 mV p-p on the X-axis.
- If the waveform is less than 18 mV p-p, then decrease the value of A3R83. If the waveform is greater than 20 mV p-p, increase the value of A3R83.

8-34. Procedure to Select A3R29 on the Amplifier Buffer Assembly

- Connect the Signal OUT from the function generator (HP 3325A) to the 5335A Channel B INPUT, and to the B INPUT on the oscilloscope (HP 1725A).
- Connect the A PROBE from the oscilloscope to resistor R33 on the A2 assembly (A2R33), between R33 and the anode of CR6.
- Set the test equipment as described in the procedure to select A3R83, (paragraph 8-33 steps c through e).
- Set the oscilloscope for the X-Y mode, and calibrate by centering the dot at center screen.
- Adjust A3R47 (offset) to position the waveform at the center of the scope screen. Adjust A3R37 (hysteresis) for 18 to 20 mV p-p on the X-axis.
- If the waveform is less than 18 mV p-p, then decrease the value of A3R29. If the waveform is greater than 20 mV p-p, increase the value of A3R29.

8-35. Procedure to Select the X10 Compensating Capacitors A3C37 And A3C23

- Connect the 8640B Signal Generator RF output to 5335A input A as shown in *Figure 8-2*.

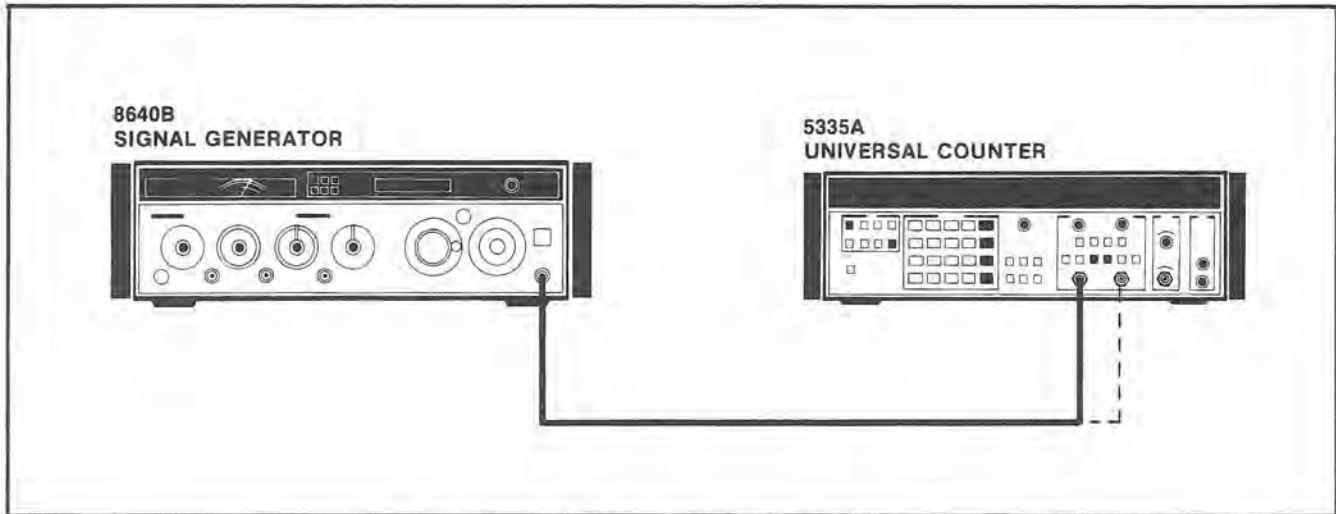

Figure 8-2. Test Setup for A3C37 and C23 Selection

- b. Set 5335A front panel controls as follows:

FUNCTION FREQ A
 GATE MODE NORM
 CYCLE NORM
 INPUT (CHANNELS A and B):
 1 M/50 ohm 50 ohm
 TRIGGER LEVEL PRESET
 X10/X1 ATTEN X1
 AC/DC DC
 COM A OUT
 AUTO TRIG OUT

c. Set the 8640B to output a 10 MHz signal at 25 mV rms. Verify that the 5335A counter displays the frequency output of the signal generator.

d. Reduce the signal level slowly until the 5335A stops giving the correct reading; record this level (minimum sensitivity).

e. Set the generator to output a 100 MHz at 25 mV rms and repeat step d. Do the same at 200 MHz. Record all readings.

f. Set Channel A attenuator to X10 and repeat steps c through e above, adjusting the signal generator output.

g. Take the ratio of the readings of minimum sensitivity of X10 to X1 at 10 MHz, 100 MHz and 200 MHz. If the ratio is greater than 14, use the 18 pF capacitor (P/N 0160-4492); if the ratio is less than 6, use the 27 pF capacitor (P/N 0160-4493). This is summarized in the following table:

| Ratio | Capacitor Value, pF | HP P/N |
|-------|---------------------|-----------|
| >14 | 18 | 0160-4492 |
| <6 | 27 | 0160-4493 |

Nominal value for A3C37 and C23: 22 pF, P/N 0160-3875.

h. Repeat steps c through g to verify that the ratio is between 7 and 13. If it is outside this range, then a problem exists elsewhere.

i. Connect the signal generator to the 5335A Input B; set the 8640B to output a 10 MHz signal at 25 mV rms. Set 5335A to frequency B by pressing SCALE, SMOOTH, 1, 7, ENTER; verify the 5335A displays the frequency of the generator.

j. Repeat steps d through h, checking the ratio at 10 MHz, 50 MHz and at 100 MHz.

8-36. LOGIC SYMBOLS

8-37. The electronic symbology used in this book is explained starting in paragraphs 8-38.

8-38. EXPLANATION OF NEW LOGIC SYMBOLS (by F.A. Mann)*

8-39. Introduction

8-40. The International Electrotechnical Commission (IEC) has been developing a very powerful symbolic

*From "1981 Supplement to the TTL Data Book for Design Engineers", copyright © 1981 Texas Instruments Incorporated. Reproduced by permission.

language that can show the relationship of each input of a digital logic circuit to each output without showing explicitly the internal logic. At the heart of the system is dependency notation, which will be explained in a later paragraph.

8-41. The system was introduced in the USA in a rudimentary form in IEEE/ANSI Standard Y32.14-1973. Lacking at that time a complete development of dependency notation, it offered little more than a substitution of rectangular shapes for the familiar distinctive shapes for representing the basic functions of AND, OR, negation, etc. This is no longer the case.

8-42. Internationally, Working Group 2 of IEC Technical Committee TC-3 is preparing a new document (Publication 617-12) that will consolidate the original work started in the mid 1960's and published in 1972 (Publication 117-15) and the amendments and supplements that have followed. Similarly for the USA, IEEE Committee SCC 11.9 is revising the publication IEEE Standard 91/ANSI Y32.14. Texas Instruments (and Hewlett-Packard) is participating in the work of both organizations and (a) Supplement to the (Texas Instruments) TTL Data Book introduces new logic symbols in anticipation of the new standards. When changes are made as the standards develop, future editions of the TTL Data Book will take those changes into account.

8-43. The following explanation of the new symbolic language is necessarily brief and greatly condensed from what the standards publications will finally contain. This (description) is not intended to be sufficient for those people who will be developing symbols for new devices. It is primarily intended to make possible the understanding of the symbols used in this book; comparing the symbols with functional block diagrams and/or function tables will further help that understanding.

8-44. Symbol Composition

8-45. A symbol comprises an outline or a combination of outlines together with one or more qualifying symbols (characters). The shape of the symbols (outline) is not significant. As shown in Figure 8-3, general qualifying symbols are used to tell exactly what logical operation is performed by the elements. Table 8-2 shows the general qualifying symbols used in the T.I. TTL data book. Input lines are placed on the left and output lines are placed on the right. When an exception is made to that convention, the direction of signal flow is indicated by an arrow as shown in Table 8-3.

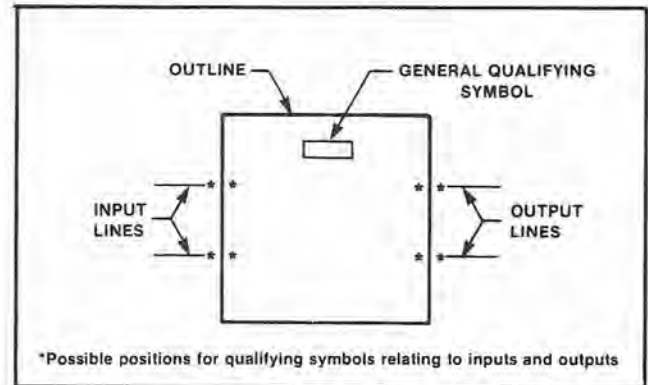

Figure 8-3. Symbol Composition

8-46. All outputs of a single, unsubdivided element always have identical internal logic states determined by the function of the element except when otherwise indicated by an associated qualifying symbol or label inside the element.

8-47. The outlines of elements may be abutted (adjoining) or embedded (enclosed) in which case the following conventions apply. There is no logic connection between the elements when the line common to their outlines is in the direction of signal flow. There is at least one logic connection between the elements when the line common to their outlines is perpendicular to the direction of signal flow. The number of logic connections between elements will be clarified by the use of qualifying symbols and this is discussed further under that topic. If no indications are shown on either side of the common line, it is assumed there is only one connection.

8-48. When a circuit has one or more inputs that are common to more than one element of the circuit, the common-control block may be used. This is the only distinctively shaped outline used in the IEC system.

8-49. Figure 8-4 shows that unless otherwise qualified by dependency notation, an input to the common-control block is an input to each of the elements below the common-control block.

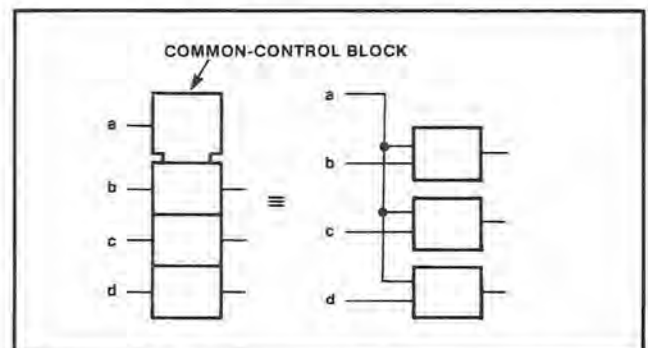

Figure 8-4. Illustration of Common-Control Block

8-50. A common output depending on all elements of the array can be shown as the output of a common-output element. Its distinctive visual feature is the double line at its top. In addition the common-output element may have other inputs as shown in *Figure 8-5*. The function of the common-output element must be shown by use of a general qualifying symbol.

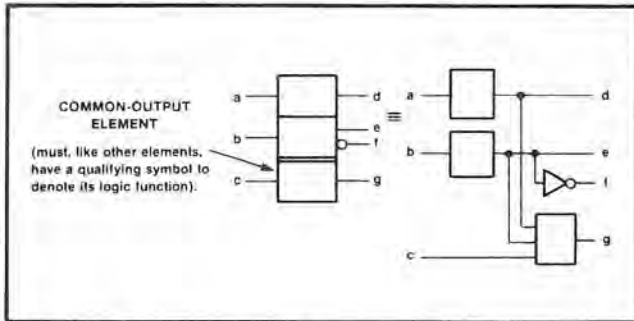

Figure 8-5. Illustration of Common-Output Element

8-51. Qualifying Symbols

8-52. GENERAL QUALIFYING SYMBOLS. *Table 8-2* shows the general symbols used in this data book. These characters are placed near the top center or the geometric center of a symbol or symbol element to define the basic function of the device represented by the symbol or of the element.

8-53. QUALIFYING SYMBOLS FOR INPUTS AND OUTPUTS. Qualifying symbols for inputs and outputs are shown in *Table 8-3* and will be familiar to most users with the possible exception of the logic polarity and analog signal indicators. The older logic negation indicator means that the external 0 (zero) state produces the internal 1 state. The internal 1 state means the active state. Logic negation may be used in pure logic diagrams; in order to tie the external 1 and 0 logic states to the level H (high) and L (low), a

Table 8-2. General Qualifying Symbols

| SYMBOL | DESCRIPTION | EXAMPLE |
|-------------------------------------|---|-----------|
| & | AND gate or function. | SN7400 |
| ≥ 1 | OR gate or function. The symbol was chosen to indicate that at least one active input is needed to activate the output. | SN7402 |
| $\equiv 1$ | Exclusive OR. One and only one input must be active to activate the output. | SN7486 |
| = | Logic identity. All inputs must stand at same state. | SN74180 |
| 2k | An even number of inputs must be active. | SN74180 |
| 2k+1 | An odd number of inputs must be active. | * |
| 1 | The one input must be active. | SN7404 |
| \triangleright or \triangleleft | A buffer or element with more than usual output capability (symbol is oriented in the direction of signal flow). | SN74S436 |
| \square | Schmitt trigger; element with hysteresis. | SN74LS18 |
| X/Y | Coder, code Converter (DEC/BCD, BIN/OCT, BIN/7-SEG, etc.). | SN74LS347 |
| MUX | Multiplexer/data selector. | SN74150 |
| DMUX or DX | Demultiplexer. | SN74138 |
| Σ | Adder. | SN74LS385 |
| P-Q | Subtractor. | SN74LS385 |
| CPG | Look-ahead carry generator. | SN74182 |
| π | Multiplier. | SN74LS384 |
| COMP | Magnitude Comparator. | SN74LS682 |
| ALU | Arithmetic logic unit. | SN74LS381 |
| \square | Retriggerable monostable. | SN74LS422 |
| 1 \square | Nonretriggerable monostable (one-shot) | SN74121 |
| \square | Astable element. (Showing waveform is optional.) | SN74LS320 |

*Not all of the general qualifying symbols have been used in this book, but they are included here for the sake of completeness.

Table 8-2. General Qualifying Symbols (Continued)

| SYMBOL | DESCRIPTION | EXAMPLE |
|----------------------|--|-----------|
| !G | Synchronously starting astable. | SN74LS624 |
| G! | Astable element that stops with a completed pulse. | SN74LS624 |
| SRG _m | Shift register. m = number of bits. | SN74LS595 |
| CTR _m | Counter. m = number of bits; cycle length = 2m. | SN54LS590 |
| CTR DIV _m | Counter with cycle length = m. | SN74LS668 |
| ROM | Read-only memory. | * |
| RAM | Random-access read/write memory. | SN74170 |
| FIFO | First-in, first-out memory. | SN74LS222 |

statement of whether positive logic (1=H, 0=L) or negative logic (1=L, 0=H) is being used is required or must be assumed. Logic polarity indicators eliminate the need for calling out the logic convention and are used in this (T.I.) data book in the symbology for actual devices. The presence of the triangular polarity indicator indicates that the Low logic level will produce the internal 1 state (the active state) or that, in the case of an output, the internal 1 state will produce the external Low level. Note how the active direction of transition for a dynamic input is indicated in positive logic, negative logic, and with polarity indication.

8-54. The internal connections between logic elements abutted together in a symbol may be indicated by the symbols shown. Each logic connection may be shown by the presence of qualifying symbols at one or both sides of the common line and if confusion can arise about the numbers of connections, use can be made of one of the internal connection symbols.

8-55. The internal (virtual) input is an input originating somewhere else in the circuit and is not connected directly to a terminal. The internal (virtual) output is likewise not connected directly to a terminal.

8-56. The application of internal inputs and outputs requires an understanding of dependency notation, which is explained in paragraph 8-65.

8-57. In an array of elements, if the same general qualifying symbol and the same qualifying symbols associated with inputs and outputs would appear inside each of the elements of the array, these qualifying symbols are usually shown only in the first element. This is done to reduce clutter and to save time in recognition. Similarly, large identical elements that are subdivided into smaller elements may each be represented by an unsubdivided outline. The SN54LS440 symbol illustrates this principle.

8-58. SYMBOLS INSIDE THE OUTLINE. *Table 8-4* shows some symbols used inside the outline. Note particularly that open-collector, open-emitter, and three-state outputs have distinctive symbols. Also note that an EN input affects all the outputs of the circuit and has no effect on inputs. When an enable input affects only certain outputs and/or affects one or more inputs, a form of dependency notation will indicate this (see paragraph 8-100). The effects of the EN input on the various types of outputs are shown.

8-59. It is particularly important to note that a D input is always the data input of a storage element. At its internal 1 state, the D input sets the storage element to its 1 state, and at its internal 0 state it resets the storage element to its 0 state.

Table 8-3. Qualifying Symbols for Inputs and Outputs

| | Logic negation at input. External 0 produces internal 1. | | | | | | | | | | | | | | |
|---|---|----------------|----------------|---------------------|---------------------|---|--|--|----------|----------|----------|---|--|--|---|
| | Logic negation at output. Internal 1 produces external 0. | | | | | | | | | | | | | | |
| | Active-low input. Equivalent to in positive logic. | | | | | | | | | | | | | | |
| | Active-low output. Equivalent to in positive logic. | | | | | | | | | | | | | | |
| | Active-low input in the case of right-to-left signal flow. | | | | | | | | | | | | | | |
| | Active-low output in the case of right-to-left signal flow. | | | | | | | | | | | | | | |
| | Signal flow from right-to-left. If not otherwise indicated, signal flow is from left-to-right. | | | | | | | | | | | | | | |
| | Bidirectional signal flow. | | | | | | | | | | | | | | |
| | <table border="0"> <thead> <tr> <th></th> <th>POSITIVE LOGIC</th> <th>NEGATIVE LOGIC</th> <th>POLARITY INDICATION</th> </tr> </thead> <tbody> <tr> <td rowspan="3">} Dynamic inputs active on indicated transition</td> <td></td> <td></td> <td>NOT USED</td> </tr> <tr> <td>NOT USED</td> <td>NOT USED</td> <td>H </td> </tr> <tr> <td></td> <td></td> <td>L </td> </tr> </tbody> </table> | | POSITIVE LOGIC | NEGATIVE LOGIC | POLARITY INDICATION | } Dynamic inputs active on indicated transition | | | NOT USED | NOT USED | NOT USED | H | | | L |
| | | POSITIVE LOGIC | NEGATIVE LOGIC | POLARITY INDICATION | | | | | | | | | | | |
| } Dynamic inputs active on indicated transition | | | | NOT USED | | | | | | | | | | | |
| | NOT USED | NOT USED | H | | | | | | | | | | | | |
| | | | L | | | | | | | | | | | | |
| | | | | | | | | | | | | | | | |
| | | | | | | | | | | | | | | | |
| | Nonlogic connection. A label inside the symbol will usually define the nature of this pin. | | | | | | | | | | | | | | |
| | Input for analog signals. | | | | | | | | | | | | | | |
| | Internal connection. 1 state on left produces 1 state on right. | | | | | | | | | | | | | | |
| | Negated internal connection. 1 state on left produces 0 state on right. | | | | | | | | | | | | | | |
| | Dynamic internal connection. Transition from 0 to 1 on left produces transitory 1 state on right. | | | | | | | | | | | | | | |
| | Internal input (virtual input). It always stands at its internal 1 state unless affected by an overriding dependency relationship. | | | | | | | | | | | | | | |
| | Internal output (virtual output). Its effect on an internal input to which it is connected is indicated by dependency notation. | | | | | | | | | | | | | | |

8-60. The binary grouping symbol will be explained more fully in paragraph 8-136. Binary-weighted inputs are arranged in order and the binary weights of the least-significant and the most-significant lines are indicated by numbers. In this data book weights of input and output lines will be represented by powers of two usually only when the binary grouping symbol is used, otherwise, decimal numbers will be used. The grouped inputs generate an internal number on which a mathematical function can be performed or that can be an identifying number for dependency notation. See Figure 8-31. A frequent use is in addresses for memories.

8-61. Reversed in direction, the binary grouping

symbol can be used with outputs. The concept is analogous to that for the inputs and the weighted outputs will indicate the internal number assumed to be developed within the circuit.

8-62. Other symbols are used inside the outlines in this data book in accordance with the IEC/IEEE standards but are not shown here. Generally these are associated with arithmetic operations and are self-explanatory.

8-63. When nonstandardized information is shown inside an outline, it is usually enclosed in square brackets [like these].

Table 8-4. Symbols Inside the Outline

| | | |
|---------------|---|--|
| | Postponed output (of a pulse-triggered flip-flop). The output changes when input initiating change (e.g., a C input) returns to its initial external state or level. | |
| | Bi-threshold input (input with hysteresis). | |
| | NPN open-collector or similar output that can supply a relatively low-impedance L level when not turned off. Requires external pull-up. Capable of positive-logic wired-AND connection. | |
| | Passive-pull-up output is similar to NPN open-collector output but is supplemented with a built-in passive pull-up. | |
| | NPN open-emitter or similar output that can supply a relatively low-impedance H level when not turned off. Requires external pull-down. Capable of positive-logic wired-OR connection. | |
| | Passive-pull-down output is similar to NPN open-emitter output but is supplemented with a built-in passive pull-down. | |
| | Three-state output. | |
| | Enable input When at its internal 1-state, all outputs are enabled. When at its internal 0-state, open-collector and open-emitter outputs are off, three-state outputs are at normally defined internal logic states and at external high-impedance state, all other outputs (e.g., totem-poles) are at the internal 0-state. | |
| J, K, R, S, T | Usual meanings associated with flip-flop (e.g., R = reset, T = toggle). | |
| | Data input to a storage element equivalent to: | |
| | Shift right (left) inputs, m = 1, 2, 3, etc. If m = 1, it is usually not shown. | |
| | Counting up (down) inputs, m = 1, 2, 3, etc. If m = 1, it is usually not shown. | |
| | Binary grouping. m is highest power of 2. | |
| | The contents-setting input, when active, causes the content of a register to take on the indicated value. | |
| | The content output is active if the content of the register is as indicated. | |
| | Input line grouping indicates two or more terminals used to implement a single logic input. e.g., The paired expander inputs of SN7450. | |
| | Fixed-state output always stands at its internal 1 state. For example, see SN74185. | |

8-64. Dependency Notation

8-65. GENERAL EXPLANATION. Dependency notation is the powerful tool that sets the IEC symbols apart from previous systems and makes compact, meaningful, symbols possible. It provides the means of denoting the relationship between inputs, outputs, or inputs and outputs without actually showing all the elements and interconnections involved. The information provided by dependency notation supplements that provided by the qualifying symbols for an element's function.

8-66. In the convention for the dependency notation, use will be made of the terms "affecting" and "affected". In cases where it is not evident which inputs must be considered as being the affecting or the affected ones (e.g., if they stand in an AND relationship), the choice may be made in any convenient way.

8-67. So far, 11 types of dependency have been defined and 10 of these are used in the Texas Instruments data book. They are listed below in the order in which they are presented and are summarized in *Table 8-5*.

| Paragraph | Dependency Type or Other Subject |
|-----------|---------------------------------------|
| 8-68 | G, AND |
| 8-72 | General rules for dependency notation |
| 8-79 | V, OR |
| 8-81 | N, Negate, (Exclusive OR) |
| 8-83 | Z, Interconnection |
| 8-86 | X, Transmission |
| 8-90 | C, Control |
| 8-93 | S, Set and R, Reset |
| 8-100 | EN, Enable |
| 8-103 | M, Mode |
| 8-116 | A, Address |

Table 8-5. Summary of Dependency Notation

| TYPE OF DEPENDENCY | LETTER SYMBOL* | AFFECTING INPUT AT ITS 1-STATE | AFFECTING INPUT AT ITS 0-STATE |
|--------------------|----------------|--|--|
| Address | A | Permits action (address selected) | Prevents action (address not selected) |
| Control | C | Permits action | Prevents action |
| Enable | EN | Permits action. | Prevents action of inputs. ◊ outputs off. ∇ outputs at external high impedance no change in internal logic state. Other outputs at internal 0 state. |
| AND | G | Permits action | Imposes 0 state |
| Mode | M | Permits action (mode selected) | Prevents action (mode not selected) |
| Negate (X-OR) | N | Complements state | No effect. |
| RESET | R | Affected output reacts as it would to S = 0, R = 1 | No effect |
| SET | S | Affected output reacts as it would to S = 1, R = 0 | No effect |
| OR | V | Imposes 1 state | Permits action |
| Transmission | X | Bidirectionally connected input to output | Input to output bidirectionally not connected |
| Interconnection | Z | Imposes 1 state | Imposes 0 state |

*These letter symbols appear at the AFFECTING input (or output) and are followed by a number. Each input (or output) AFFECTED by that input is labeled with that same number. When the labels EN, R, and S appear at inputs without the following numbers, the descriptions above do not apply. The action of these inputs is described under "Symbols Inside the Outline".

8-68. G (AND) DEPENDENCY. A common relationship between two signals is to have them ANDed together. This has traditionally been shown by explicitly drawing an AND gate with the signals connected to the inputs of the gate. The 1972 IEC publication and the 1973 IEEE/ANSI standard showed several ways to show this AND relationship using dependency notation. While nine other forms of dependency have since been defined, the ways to invoke AND dependency are now reduced to one.

8-69. In *Figure 8-6* input **b** is ANDed with input **a** and the complement of **b** is ANDed with **c**. The letter G has been chosen to indicate AND relationships and is placed at input **b**, inside the symbol. A number considered appropriate by the symbol designer (1 has been used here) is placed after the letter G and also at each affected input. Note the bar over the 1 at input **c**.

8-70. In *Figure 8-7*, output **b** affects input **a** with an AND relationship. The lower example shows that it is the internal logic state of **b**, unaffected by the negation sign, that is ANDed. *Figure 8-8* shows input **a** to be ANDed with a dynamic input **b**.

8-71. The rules for G dependency can be summarized thus:

When a G_m input or output (m is a number) stand at its internal 1 state, all inputs and outputs affected by G_m stand at their normally defined internal logic states. When the G_m input or output stands at its 0 state, all inputs and outputs affected by G_m stand at their internal 0 states.

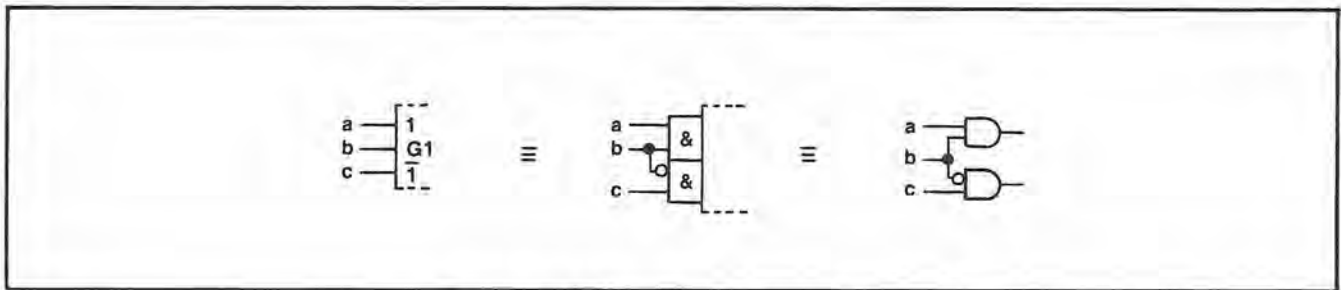

Figure 8-6. G Dependency Between Inputs

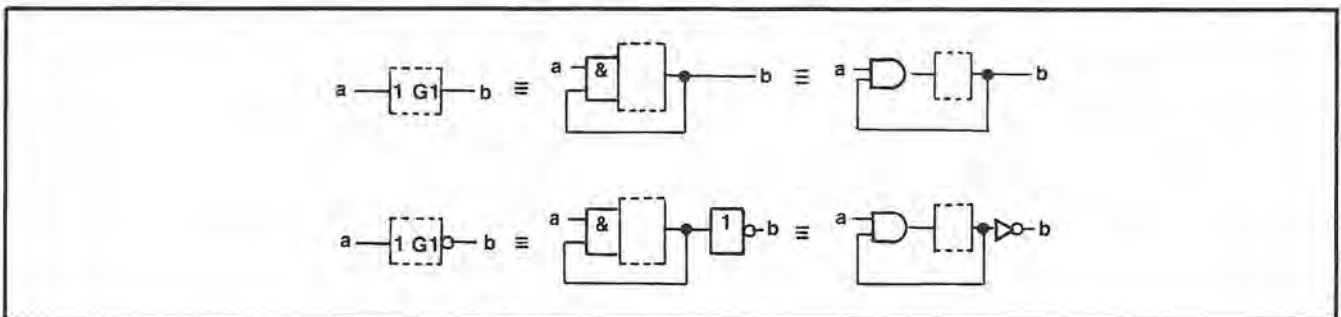

Figure 8-7. G Dependency Between Outputs and Inputs

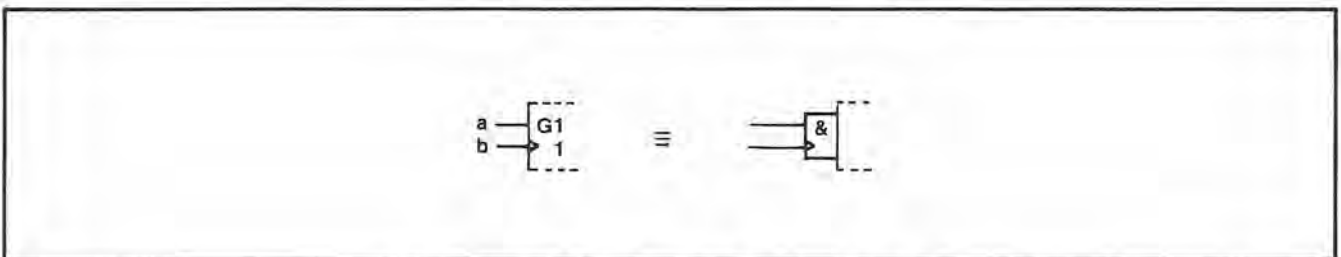

Figure 8-8. G Dependency with A Dynamic Input

8-72. CONVENTIONS FOR THE APPLICATION OF DEPENDENCY NOTATION IN GENERAL. The rules for applying dependency relationships in general follow the same pattern as was illustrated for G dependency.

8-73. Application of dependency notation is accomplished by:

- a. Labeling the input (or output) affecting other inputs or outputs with the letter symbol indicating the relationship involved (e.g., G for AND) followed by an identifying number, appropriately chosen, and;
- b. Labeling each input or output affected by that affecting input (or output) with the same number.

8-74. If it is the complement of the internal logic state of the affecting input or output that does the affecting, then a bar is placed over the identifying numbers at the affected inputs or outputs. See Figure 8-6.

8-75. If two affecting inputs or outputs have the same letter and same identifying number, they stand in an OR relationship to each other. See Figure 8-9.

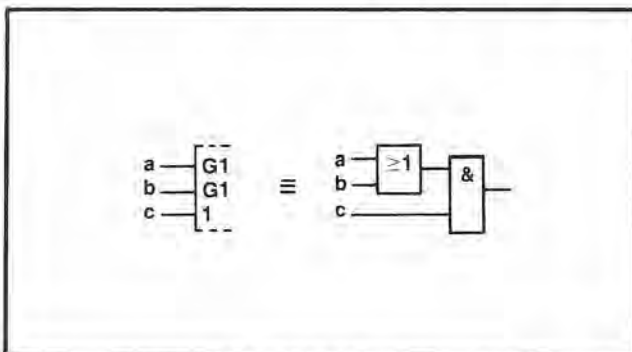

Figure 8-9. OR'ed Affecting Inputs

8-76. If the affected input or output requires a label to denote its function (e.g., "D"), this label will be prefixed by the identifying number of the affecting input. See Figure 8-15.

8-77. If an input or output is affected by more than one affecting input, the identifying numbers of each of the affecting inputs will appear in the label of the affected one, separated by commas. The normal reading order of these numbers is the same as the sequence of the affecting relationships. See Figure 8-15.

8-78. If the labels denoting the functions of affected inputs or outputs must be numbers (e.g., outputs of a coder), the identifying numbers to be associated with both affecting inputs and affected inputs or outputs will be replaced by another character selected to avoid ambiguity, e.g., Greek letters. See Figure 8-10.

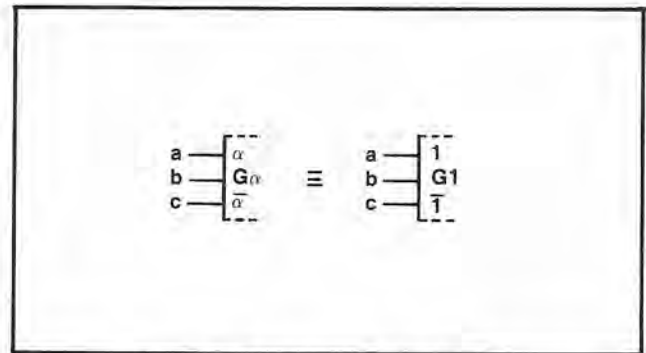

Figure 8-10. Substitution for Numbers

8-79. V (OR) DEPENDENCY. The symbol denoting OR dependency is the letter V. See Figure 8-11.

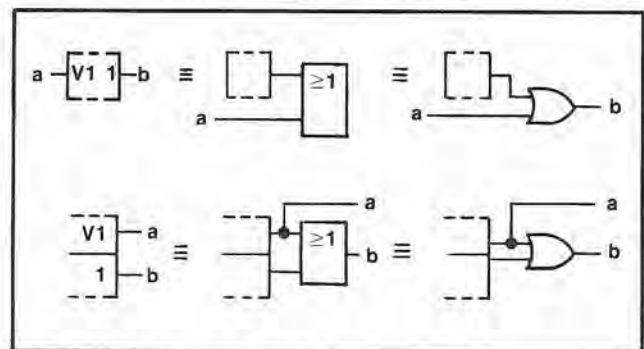

Figure 8-11. V (OR) Dependency

8-80. When a V_m input or output stands at its internal 1 state, all inputs and outputs affected by V_m stand at their internal 1 states. When the V_m input or output stands at its internal 0 state, all inputs and outputs affected by V_m stand at their normally defined internal logic states.

8-81. N (NEGATE, X-OR) DEPENDENCY. The symbol denoting negate dependency is the letter N. See Figure 8-12. Each input or output affected by an N_m input or output stands in an exclusive-OR relationship with the N_m input or output.

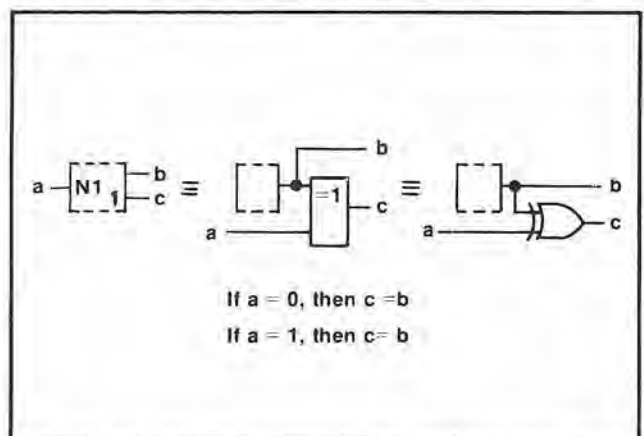

Figure 8-12. N (Negate, X-OR) Dependency

8-82. When an N_m input or output stands at its internal 1 state, the internal logic state of each input and each output affected by N_m is the complement of what it would otherwise be. When an N_m input or output stands at its internal 0 state, all inputs and outputs affected by N_m stand at their normally defined internal logic states.

8-83. Z (INTERCONNECTION) DEPENDENCY. The symbol denoting interconnection dependency is the letter Z.

8-84. Interconnecting dependency is used to indicate the existence of internal logic connections between inputs, outputs, internal inputs, and/or internal outputs.

8-85. The internal logic state of an input or output affected by a Z_m input or output will be same as the internal logic state of the Z_m input or output, unless modified by additional dependency notation. See Figure 8-13.

NOTE

Paragraphs 8-86 to 8-89 and Figure 8-14 are not taken from Texas Instruments publications.

8-86. X (TRANSMISSION) DEPENDENCY. The symbol X denotes transmission dependency.

8-87. When an X_m input or an X_m output stands at its internal 1 state, all input-output lines affected by this X_m input or X_m output are bidirectionally connected together and stand at the same internal logic state or analog signal level.

8-88. When a X_m input or X_m output stands at its internal 0 state, the connection associated with this set of dependency notation is broken.

8-89. If **a** stands at its 1 state, there is a bidirectional connection between **b** and **c**. If **a** stands at its 0 state, there is a bidirectional connection between **c** and **d**. See Figure 8-14.

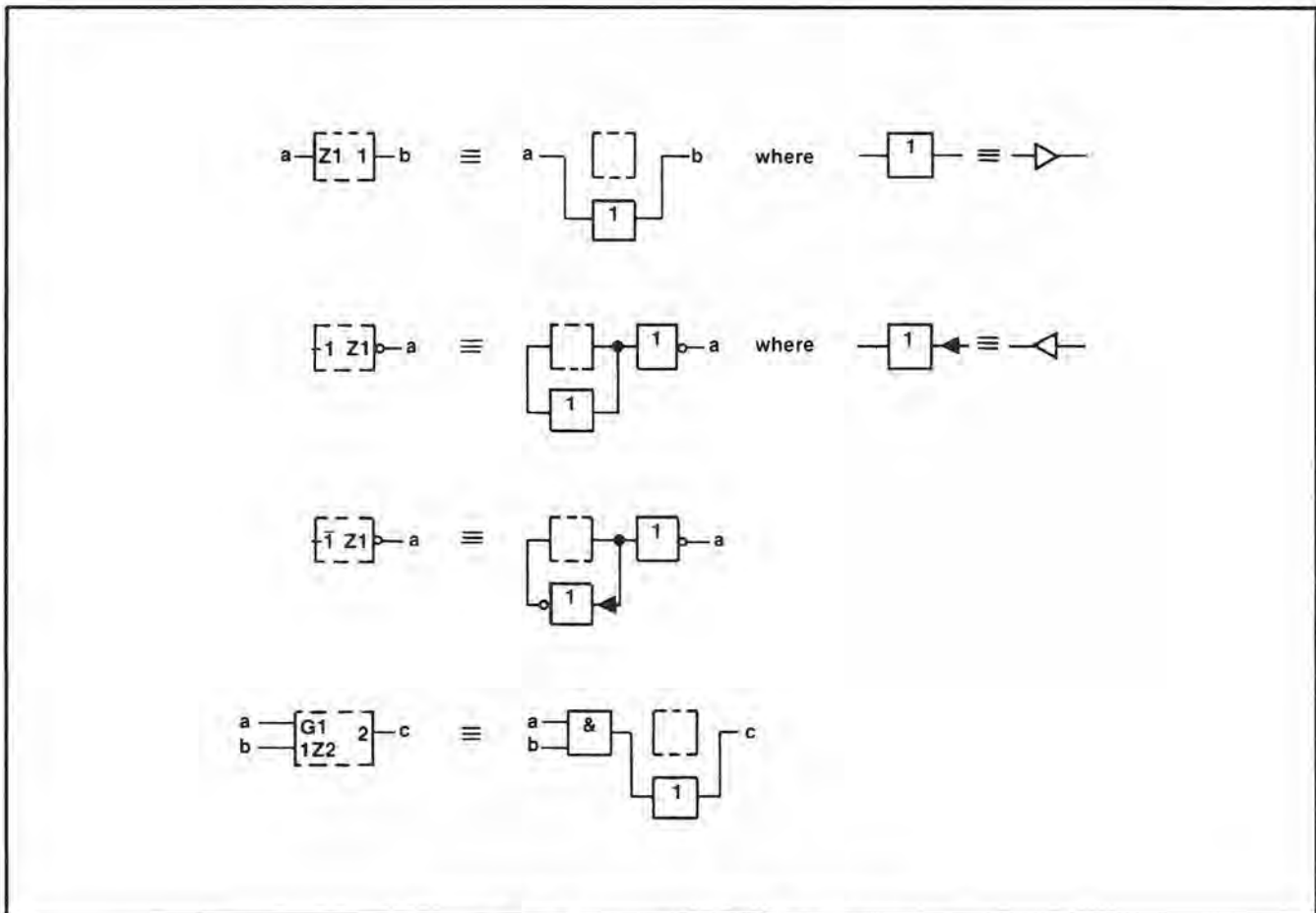

Figure 8-13. Z (Interconnection) Dependency

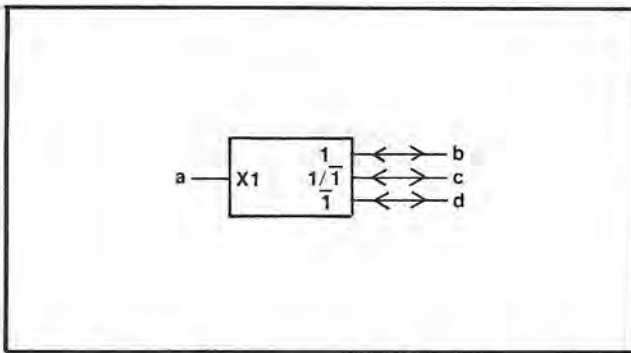

Figure 8-14. X (Transmission) Dependency

8-90. C (CONTROL) DEPENDENCY. The symbol denoting control dependency is the letter C.

8-91. Control inputs are usually used to enable or disable the data (D, J, K, R, or S) inputs of storage elements. They may take on their internal 1 states (be active) either statically or dynamically. In the latter case the dynamic input symbol is used as shown in the third example of Figure 8-15.

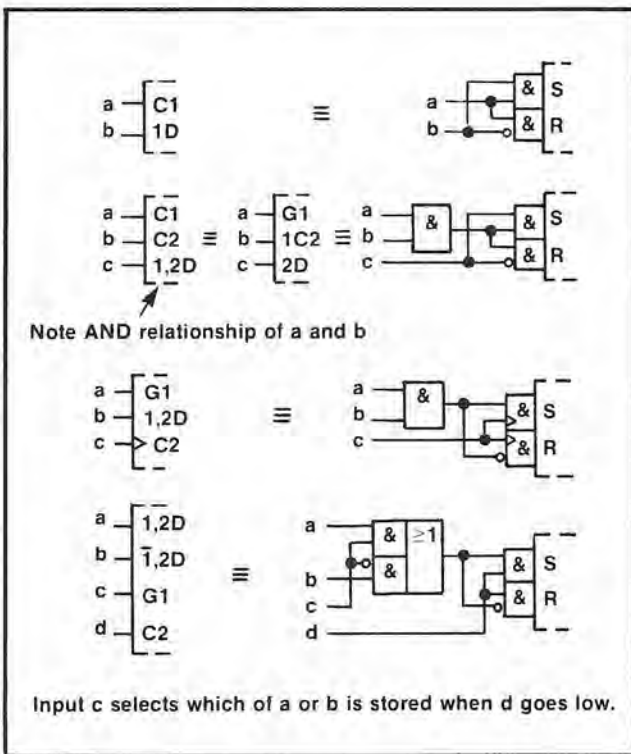

Figure 8-15. C (Control) Dependency

8-92. When a C_m input or output stands at its internal 1 state, the inputs affected by C_m have their normally defined affect on the function of the element, i.e., these inputs are enabled. When a C_m input or output stands at its internal 0 state, the inputs affected by C_m are disabled and have no effect on the function of the element.

8-93. S (SET) and R (RESET) DEPENDENCIES. The symbol denoting set dependency is the letter S. The symbol denoting reset dependency is the letter R.

8-94. Set and reset dependencies are used if it is necessary to specify the effect of the combination $R=S=1$ on a bistable element. Case 1 in Figure 8-16 does not use S or R dependency.

8-95. When an S_m input is at its internal 1 state, outputs affected by the S_m input will react, regardless of the state of an R input, as they normally would react to the combination $S=1, R=0$. See cases 2, 4, and 5 in Figure 8-16.

8-96. When an R_m input is at its internal 1 state, outputs affected by the R_m input will react, regardless of the state of an S input, as they normally would react to the combination $S=0, R=1$. See cases 3, 4, and 5 in Figure 8-16.

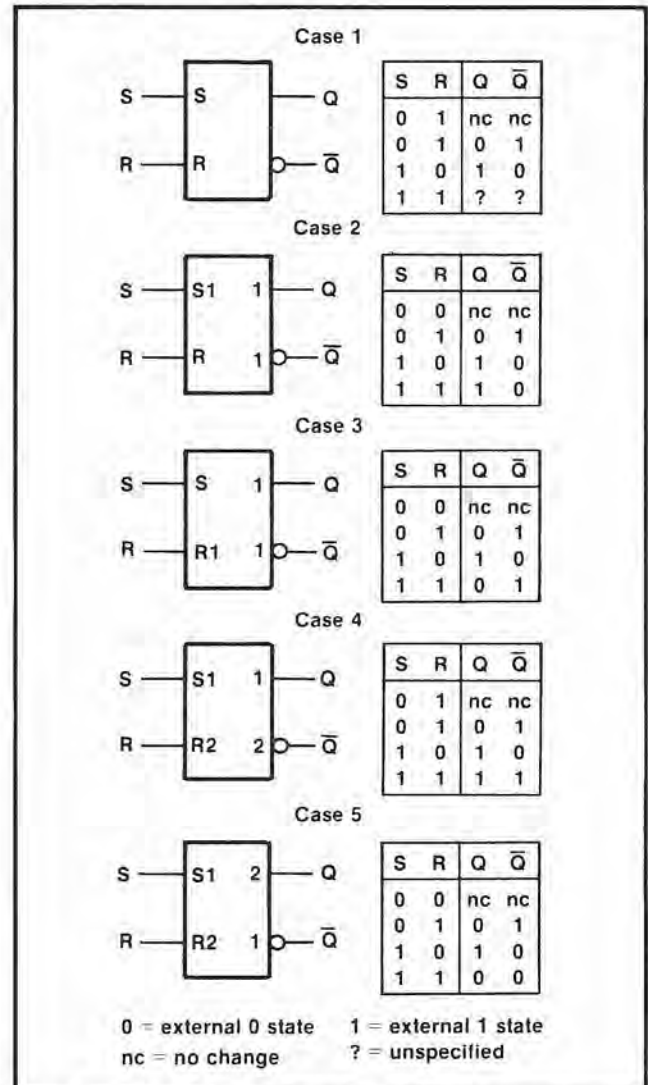

Figure 8-16. S (Set) and R (Reset) Dependencies

8-97. When an S_m or R_m input is at its internal 0 state, it has no effect.

8-98. Note that the noncomplementary output patterns in cases 4 and 5 are only pseudostable. The simultaneous return of the inputs to $S=R=0$ produces an unforeseeable stable and complementary output pattern.

8-99. EN (ENABLE) DEPENDENCY. The symbol denoting enable dependency is the combination of letters EN.

8-100. An EN_m input has the same effect on outputs as an EN input, see paragraph 8-52, but it effects only those outputs labeled with the identifying number m . It also affects those inputs labeled with the identifying number m . By contrast an EN input affects all outputs and no inputs. The effect of an EN_m input on an affected input is identical to that of a C_m input. See Figure 8-17.

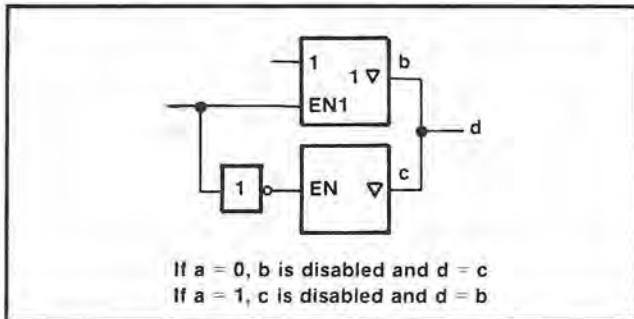

Figure 8-17. EN (Enable) Dependency

8-101. When an EN_m input stands at its internal 1 state, the inputs affected by EN_m have their normally defined effect on the function of the element and the outputs affected by this input stand at their normally defined internal logic states, i.e., these inputs and outputs are enabled.

8-102. When an EN_m input stands at its internal 0 state, the inputs affected by EN_m are disabled and have no effect on the function of the element, and the outputs affected by EN_m are also disabled. Open-collector outputs are turned off, three-state outputs stand at their normally defined internal logic states but externally exhibit high impedance, and all other outputs (e.g., totem-pole outputs) stand at their internal 0 states.

8-103. M (MODE) DEPENDENCY. The symbol denoting mode dependency is the letter M.

8-104. Mode dependency is used to indicate that the effects of particular inputs and outputs of an element depend on the mode in which the element is operating.

8-105. If an input or output has the same effect in different modes of operation, the identifying numbers of the relevant affecting M_m inputs will appear in the label of that affected input or output between parentheses and separated by solidi. See Figure 8-22.

8-106. M DEPENDENCY AFFECTING INPUTS. M dependency affects inputs the same as C dependency. When an M_m input or M_m output stands at its internal 1 state, the inputs affected by this M_m input or M_m output have their normally defined effect on the function of the element, i.e., the inputs are enabled.

8-107. When an M_m input or M_m output stands at its internal 0 state, the inputs affected by this M_m input or M_m output have no effect on the function of the element. When an affected input has several sets of labels separated by solidi (e.g., $C_4/2-/3+$), any set in which the identifying number of the M_m input or M_m output appears has no effect and is to be ignored. This represents disabling of some of the functions of a multifunction input.

8-108. The circuit in Figure 8-18 has two inputs, b and c , that control which one of four modes (0, 1, 2, or 3) will exist at any time. Inputs d , e , and f are D inputs subject to dynamic control (clocking) by the a input. The numbers 1 and 2 are in the series chosen to indicate the modes so inputs e and f are only enabled in mode 1 (for parallel loading) and input d is only enabled in mode 2 (for serial loading). Note that input a has three functions. It is the clock for entering data. In mode 2, it causes right shifting of data, which means a shift away from the control block. In mode 3, it causes the contents of the register to be incremented by one count.

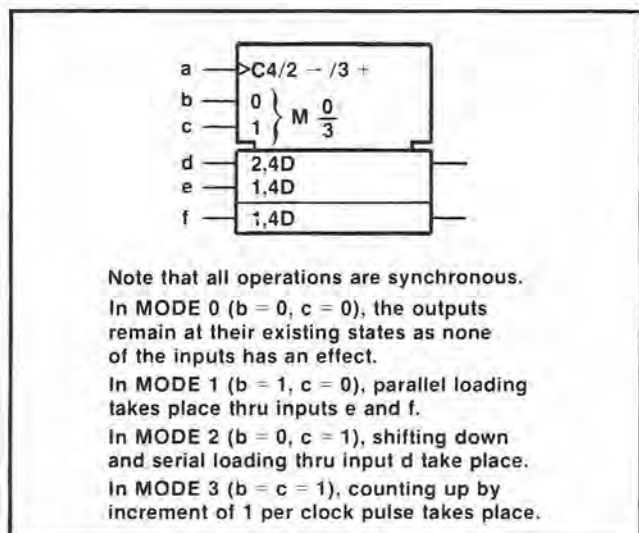

Figure 8-18. M (Mode) Dependency

8-109. M DEPENDENCY AFFECTING OUTPUTS. When an Mm input or Mm output stands at its internal 1 state, the affected outputs stand at their normally defined internal logic states, i.e., the outputs are enabled.

8-110. When an Mm input or Mm output stands at its internal 0 state, at each affected output any set of labels containing the identifying number of that Mm input or Mm output has no effect and is to be ignored. When an output has several different sets of labels separated by solidi (e.g., 2, 4/3, 5), only those sets in which the identifying number of this Mm input or Mm output appears are to be ignored.

8-111. In Figure 8-19, mode 1 exits when the a input stands at its internal 1 state. The delayed output symbol is effective only in mode 1 (when input a = 1) in which case the device functions as a pulse-triggered flip-flop. See paragraphs 8-124 through 8-128. When input a = 0, the device is not in mode 1 so the delayed output symbol has no effect and the device functions as a transparent latch.

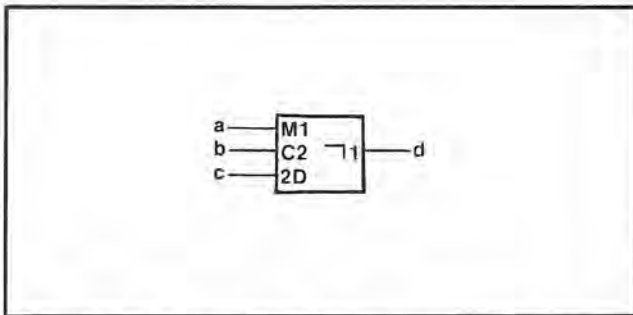

Figure 8-19. Type of Flip-Flop Determined by Mode

8-112. In Figure 8-20, if input a stands at its internal 1 state establishing mode 1, output b will stand at its internal 1 state only when the content of the register equal 9. Since output b is located in the common-control block with no defined function outside of mode 1, this output will stand at its internal 0 state when input a stands at its internal 0 state, regardless of the register content.

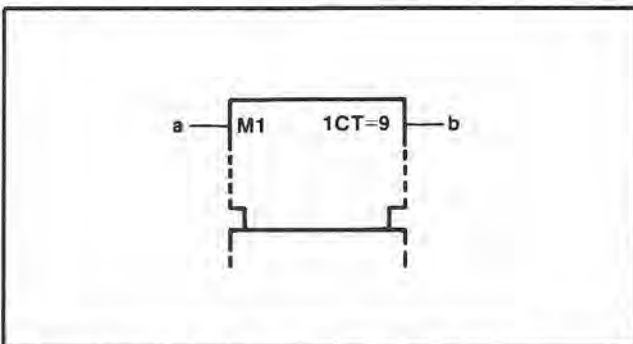

Figure 8-20. Disabling an Output of the Common Control Block

8-113. In Figure 8-21, if input a stands at its internal 1 state establishing mode 1, output b will stand at its internal 1 state only when the content of the register equals 15. If input a stands at its internal 0 state, output b will stand at its internal 1 state only when the content of the register equals 0.

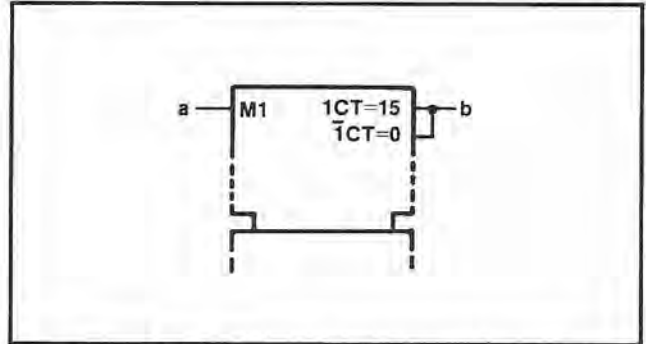

Figure 8-21. Determining an Output Function

8-114. In Figure 8-22 inputs a and b are binary weighted to generate the numbers 0, 1, 2, or 3. This determines which one of the four modes exists.

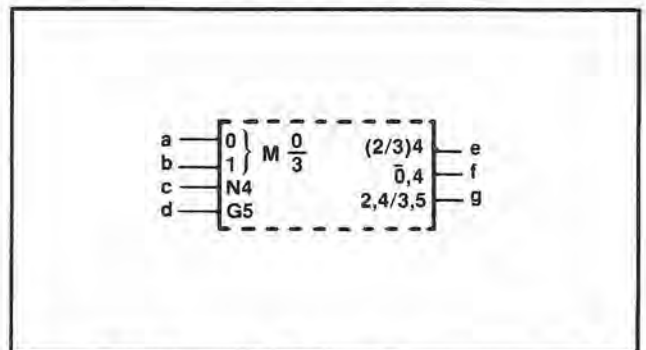

Figure 8-22. Dependent Relationship Affected by Mode

8-115. At output e the label set causing negation (if c = 1) is effective only in modes 2 and 3. In modes 0 and 1 this output stands at its normally defined state as if it had no labels. At output f the label set has effect when the mode is not 0 so output e is negated (if c = 1) in modes 1, 2, and 3. In mode 0 the label set has no effect so the output stands at its normally defined state. In this example 0, 4 is equivalent to (1/2/3)4. At output g there are two label sets. the first set, causing negation (if c = 1), is effective only in mode 2. The second set, subjecting g to AND dependency on d, has effect only in mode 3.

8-116. A (ADDRESS) DEPENDENCY. The symbol denoting address dependency is the letter A.

8-117. Address dependency provides a clear representation of those elements, particularly memories, that use address control inputs to select specified

sections of a multidimensional array. Such a section of a memory array is usually called a word. The purpose of address dependency is to allow a symbolic presentation of the entire array. An input of the array shown at a particular element of this general section is common to the corresponding elements of all selected sections of the array. An output of the array shown at a particular element of this general section is the result of the OR function of the outputs of the corresponding elements of selected sections. If the label of an output of the array shown at a particular element of this general section indicates that this output is an open-circuit output or a three-state output, then this indication refers to the output of the array and not to those of the sections of the array.

8-118. Inputs that are not affected by any affecting address input have their normally defined effect on all sections of the array, whereas inputs affected by an address input have their normally defined effect only on the section selected by that address input.

8-119. An affecting address input is labeled with the letter A followed by an identifying number that corresponds with the address of the particular section of the array selected by this input. Within the general section presented by the symbol, inputs and outputs affected by an A_m input are labeled with the letter A, which stands for the identifying numbers, i.e., the addresses, of the particular sections.

8-120. Figure 8-23 shows a 3-word by 2-bit memory having a separate address line for each word and uses EN dependency to explain the operation. To select word 1, input a is taken to its 1 state, which establishes mode 1. Data can now be clocked into the inputs marked "1, 4D". Unless words 2 and 3 are also selected, data cannot be clocked in at the inputs marked "2, 4D" and "3, 4D". The outputs will be the OR functions of the selected outputs, i.e., only those enabled by the active EN functions.

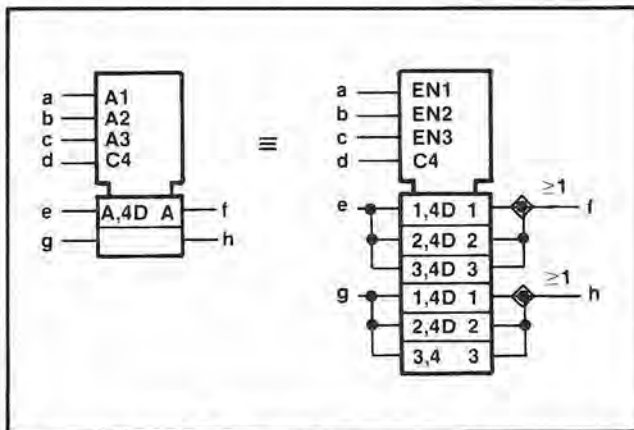

Figure 8-23. A (Address) Dependency

8-121. The identifying numbers of affecting address inputs correspond with the addresses of the sections selected by these inputs. They need not necessarily differ from those of other affecting dependency-inputs (e.g., G, V, N, ...), because in the general section presented by the symbol they are replaced by the letter A.

8-122. If there are several sets of affecting A_m inputs for the purpose of independent and possibly simultaneous access to sections of the array, then the letter A is modified to 1A, 2A, ..., because they have access to the same sections of the array, these sets of A inputs may have the same identifying numbers.

8-123. Figure 8-24 is another illustration of the A (Address) dependency.

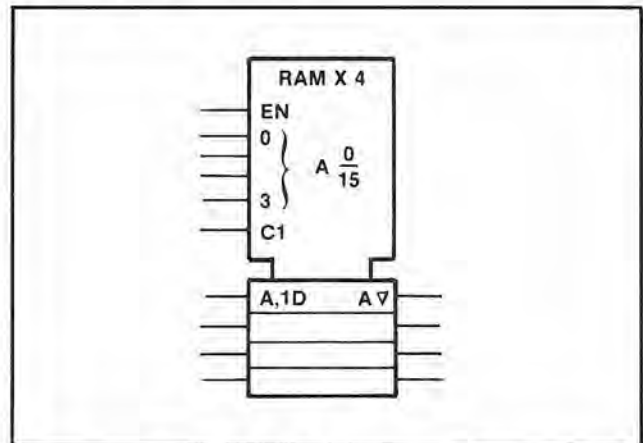

Figure 8-24. RAM Example*

*Array of 16 sections of four transparent latches with three-state outputs comprising a 16-word by four-bit random access memory.

8-124. Bistable Elements

8-125. The dynamic input symbol, the postponed output symbol, and dependency notation provide the tools to differentiate four main types of bistable elements and make synchronous and asynchronous inputs easily recognizable. See Figure 8-25. The first column shows the essential distinguishing features; the other columns show examples.

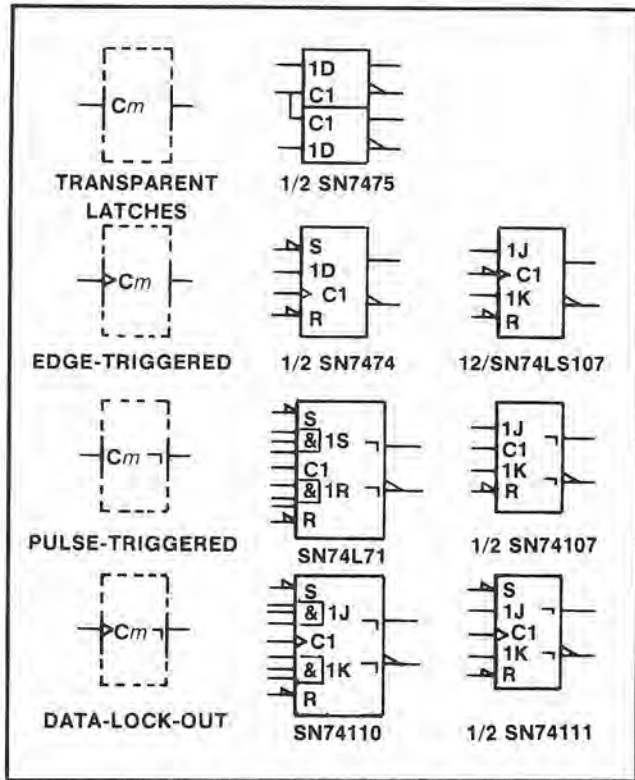

Figure 8-25. Four Types of Bistable Circuits

8-126. Transparent latches have a level-operated control input. The D input is active as long as the C input is at its internal 1 state. The outputs respond immediately. Edge-triggered elements accept data from D, J, K, R, or S inputs on the active transition of C. Pulse-triggered elements require the setup of data before the start of the control pulse; the C input is considered static since the data must be maintained as long as C is at its 1 state. The output is postponed until C returns to its 0 state. The data-lock-out element is similar to the pulse-triggered version except that the C input is considered dynamic in that shortly after C goes through its active transition, the data inputs are disabled and data does not have to be held. However, the output is still postponed until the C input returns to its initial external level.

8-127. Notice that synchronous inputs can be readily recognized by their dependency (1D, 1J, 1K, 1S, 1R) compared to the asynchronous inputs (S,R), which are not dependent on the C inputs.

8-128. Coders

8-129. The general symbol for a coder or code converter is shown in Figure 8-26. X and Y may be replaced by appropriate indications of the code used to represent the information at the inputs and at the outputs, respectively.

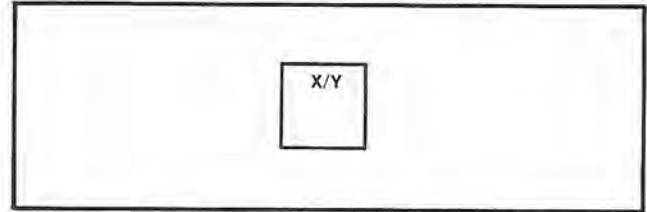

Figure 8-26. Coder General Symbol

8-130. Indication of code conversion is based on the following rule:

Depending on the input code, the internal logic states of the inputs determine an internal value. This value is reproduced by the internal logic states of the outputs, depending on the output code.

8-131. The indication of the relationships between the internal logic states of the inputs and the internal value is accomplished by:

- a. Labeling the inputs with numbers. In this case the internal value equals the sum of the weights associated with those inputs that stand at their internal 1 state, or by;
- b. Replacing X by an appropriate indication of the input code and labeling the inputs with characters that refer to this code.

8-132. The relationships between the internal value and the internal logic states of the outputs are indicated by:

- a. Labeling each output with a list of numbers representing those internal values that lead to the internal 1 state of that output. These numbers shall be separated by solidi (slant:/) as in Figure 8-27. This labeling may also be applied when Y is replaced by a letter denoting a type of dependency (see paragraphs 8-134 and 8-135). If a continuous range of internal values produces the internal 1 state of an output, this can be indicated by two numbers that are inclusively the beginning and the end of the range, with these two numbers separated by three dots, e.g., 4...9 = 4/5/6/7/8/9, or by;

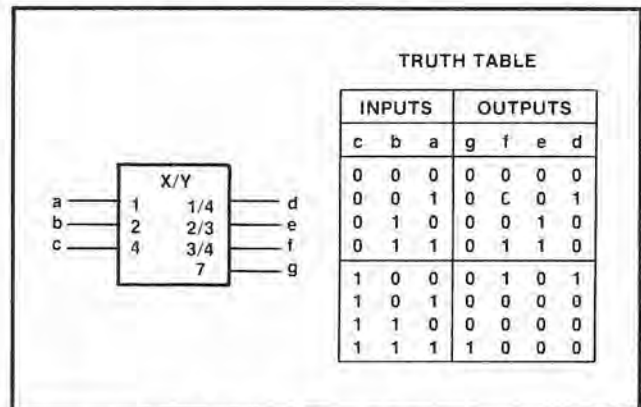

Figure 8-27. An X-Y Code Converter

b. Replacing Y by an appropriate indication of the output code and labeling the outputs with characters that refer to this code as in Figure 8-28.

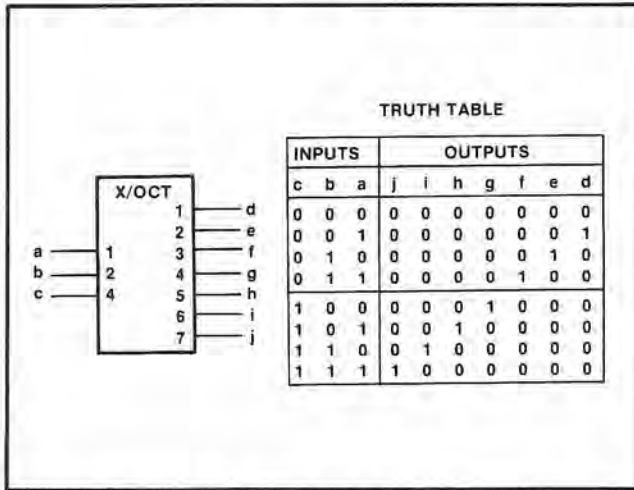

Figure 8-28. An X-Octal Code Converter

8-133. Alternatively, the general symbol may be used together with an appropriate reference to a table in which the relationship between the inputs and outputs is indicated. This is a recommended way to symbolize a PROM after it has been programmed.

8-134. USE OF A CODER TO PRODUCE AFFECTING INPUTS. If often occurs that a set of affecting inputs for dependency notation is produced by decoding the signals on certain inputs to an element. In such a case use can be made of the symbol for a coder as an embedded symbol. See Figure 8-29.

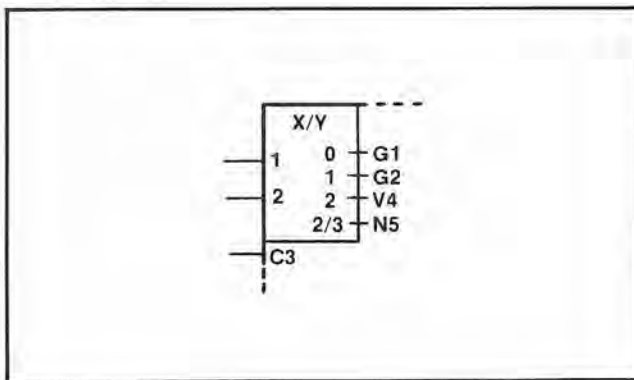

Figure 8-29. Coder Producing Several Dependencies

8-135. If all affecting inputs produced by a coder are of the same type and their identifying numbers correspond with the numbers shown at the outputs of the coder, Y (in the qualifying symbol X/Y) may be replaced by the letter denoting the type of dependency. The indications of the affecting inputs should then be omitted. See Figure 8-30.

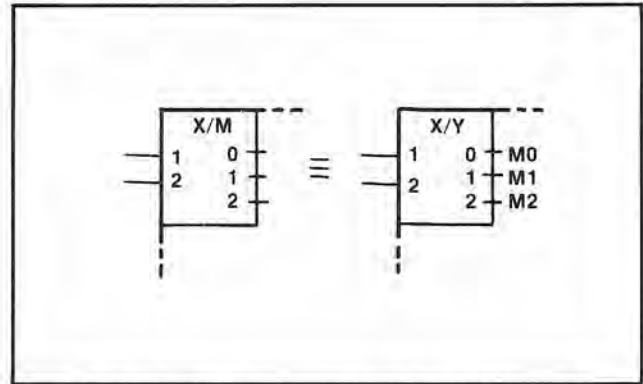

Figure 8-30. Coder Producing One Type of Dependency

8-136. Use of Binary Grouping to Produce Affecting Inputs

8-137. If all affecting inputs produced by a coder are of the same type and have consecutive identifying numbers not necessarily corresponding with the numbers that would have been shown at the outputs of the coder, use can be made of the binary grouping symbol (see paragraph 8-60), k external lines effectively generate $2k$ internal inputs. The bracket is followed by the letter denoting the type of dependency followed by $m1/m2$. The $m1$ is to be replaced by the smallest identifying number and the $m2$ by the largest one, as shown in Figure 8-31.

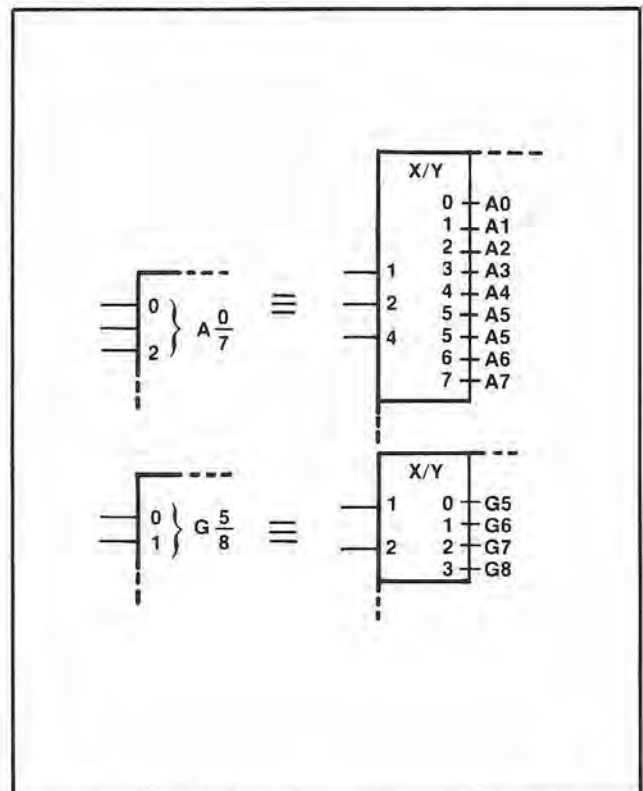

Figure 8-31. Use of Binary Grouping Symbol

8-138. Sequence of Input Labels

8-139. If an input having a single functional effect is affected by other inputs, the qualifying symbol (if there is any) for that functional effect is preceded by the labels corresponding to the affecting inputs. The left-to-right order of these preceding labels is the order in which the effects or modifications labels must be applied. The affected input has no functional effect on the element if the logic state of any one of the affecting inputs, considered separately, would cause the affected input to have no effect, regardless of the logic states of other affecting inputs.

8-140. If an input has several different functional effects or has several different sets of affecting inputs, depending on the mode of action, the input may be shown as often as required. However, there are cases in which this method of presentation is not advantageous. In those cases the input may be shown once with the different sets of labels separated by solidi. See Figure 8-32. No meaning is attached to the order of these sets of labels. If one of the functional effects of an input is that of an unlabeled input of the element, a solidus will precede the first set of labels shown.

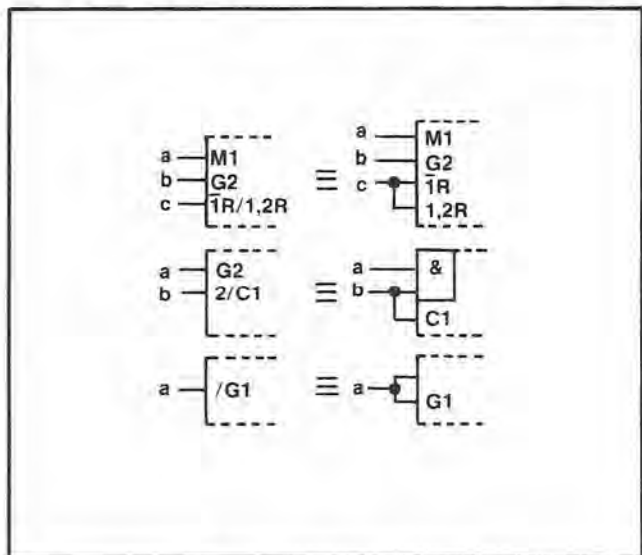

Figure 8-32. Input Labels

8-141. If all inputs of a combinational element are disabled (caused to have no effect on the function of the element), the internal logic states of the outputs of the element are not specified by the symbol. If all inputs of a sequential element are disabled, the content of this element is not changed and the outputs remain at their existing internal logic states.

8-142. Input labels may be factored using algebraic techniques. See Figure 8-33.

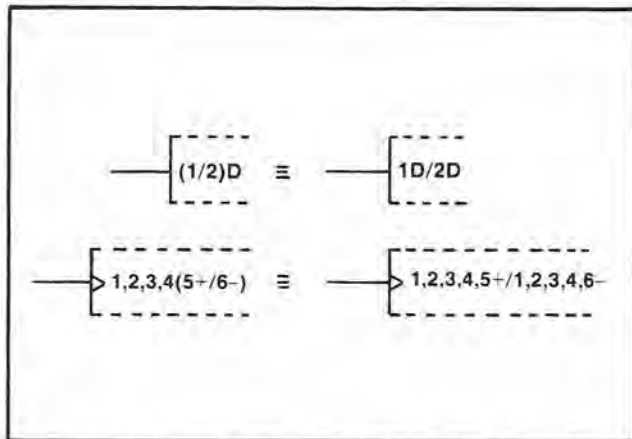

Figure 8-33. Factoring Input Labels

8-143. Sequence of Output Labels

8-144. If an output has a number of different labels, regardless of whether they are identifying numbers of affecting inputs or outputs or not, these labels are shown in the following order:

- a. If the postponed output symbol has to be shown, this comes first, if necessary preceded by the indications of the inputs to which it must be applied;
- b. Followed by the labels indicating modifications of the internal logic state of the output, such that the left-to-right order of these labels corresponds with the order in which their effects must be applied;
- c. Followed by the label indicating the effect of the output on inputs and other outputs of the element.

8-145. Symbols for open-circuit or three-state outputs, where applicable, are placed just inside the outside boundary of the symbol adjacent to the output line. See Figure 8-34.

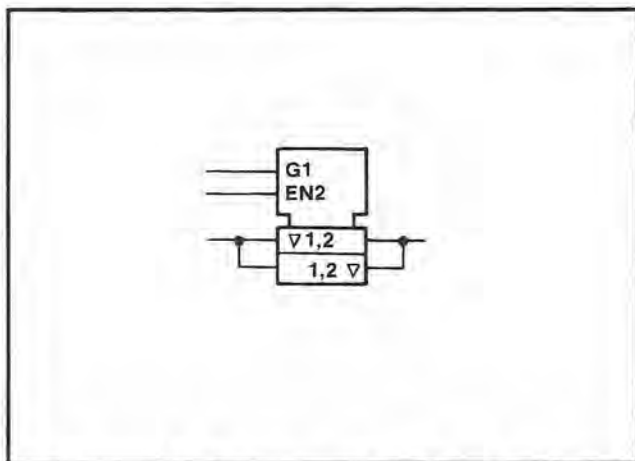

Figure 8-34. Placement of Three-State Symbols

8-146. If an output needs several different sets of labels that represent alternative functions (e.g., depending on the mode of action), these sets may be shown on different output lines that must be connected outside the outline. However, there are cases in which this method of presentation is not advantageous. In those cases the output may be shown once with the different sets of labels separated by solidi. See *Figure 8-35*.

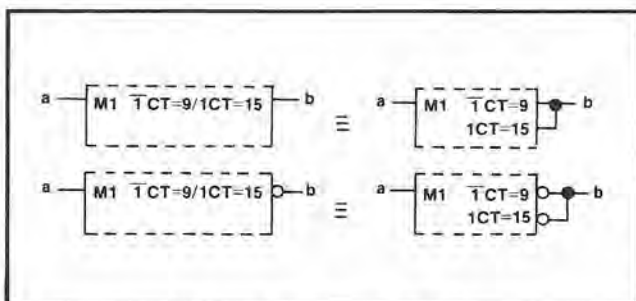

Figure 8-35. Output Labels

8-147. Two adjacent identifying numbers of affecting inputs in a set of labels that are not already separated by a nonnumeric character should be separated by a comma.

8-148. If a set of labels of an output not containing a solidus contains the identifying number of an affecting Mm input standing at its internal 0 state, this set of labels has no effect on that output.

8-149. Labels may be factored using algebraic techniques. See *Figure 8-36* for output label factoring.

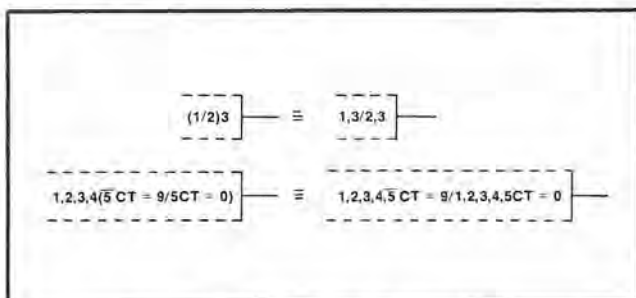

Figure 8-36. Factoring Output Labels

8-150. THEORY OF OPERATION

8-151. Overall Counter Operation

8-152. The HP Model 5335A is a Universal Counter, with measurement capabilities that include frequency, period, time, ratio, totalize, and volts. The following description introduces the major functional circuit blocks, and refers to the Simplified Block Diagram in *Figure 8-37*.

8-153. The overall operation of the counter centers on the continuous interaction of the multiple-register-counter (MRC) and the controlling microprocessor system. The MRC, referred to as a "counter-on-a-chip" is an LSI circuit, which contains the counting registers used to accumulate the raw input measurement data. The microprocessor system contains the processor, counter operating program (in ROM), and memory space (in RAM).

8-154. Inputs to channel A (and/or Channel B) are routed through signal conditioning circuits which perform the operator selections of coupling, impedance, and attenuation. The signal is directed through a parallel input buffer stage, (which provides separate buffers for high and low frequency signals), through a protective limiter, to the input Schmitt amplifier where it is buffered, shaped, level-shifted and input to the respective channel signal multiplexer. The A and B channel signal multiplexers accept the various input signals and direct the required signal to the MRC inputs. The trigger mode circuit configures the type of input channel triggering selected; either manual or automatic, preset or adjustable. Both input channels have peak detector circuits which during automatic modes, are used to derive DC levels representing the positive and negative peaks of the input. From these, the 50%, 10% and 90% points of the input signals can be used.

8-155. The outputs of the channel A and channel B signal multiplexers are directed to the MRC, where they are accumulated in registers, counted, and stored as raw measurement data. The data is then retrieved by the microprocessor system, manipulated to achieve the desired measurement mode, modified by special functions (if required) and routed to the display. The local reference oscillator is directed to the MRC through the oscillator select circuit. An interpolating configuration divides up the time between time base pulses, and allows the MRC to count with much finer resolution. For a typical measurement, the microprocessor reads the MRC registers, reads the interpolator counters, performs the necessary calculations and displays the result. In between measurements, the MRC registers and the interpolator counters are reset. The microprocessor system operates on a program, permanently stored in ROM, which allows it to continually cycle, making measurements, while routinely monitoring the MRC, the front panel keyboard, and the HP-IB for inputs and interrupts. Additionally, the program in ROM provides for operator interactive diagnostics, used during troubleshooting.

Figure 8-37. Simplified Block Diagram

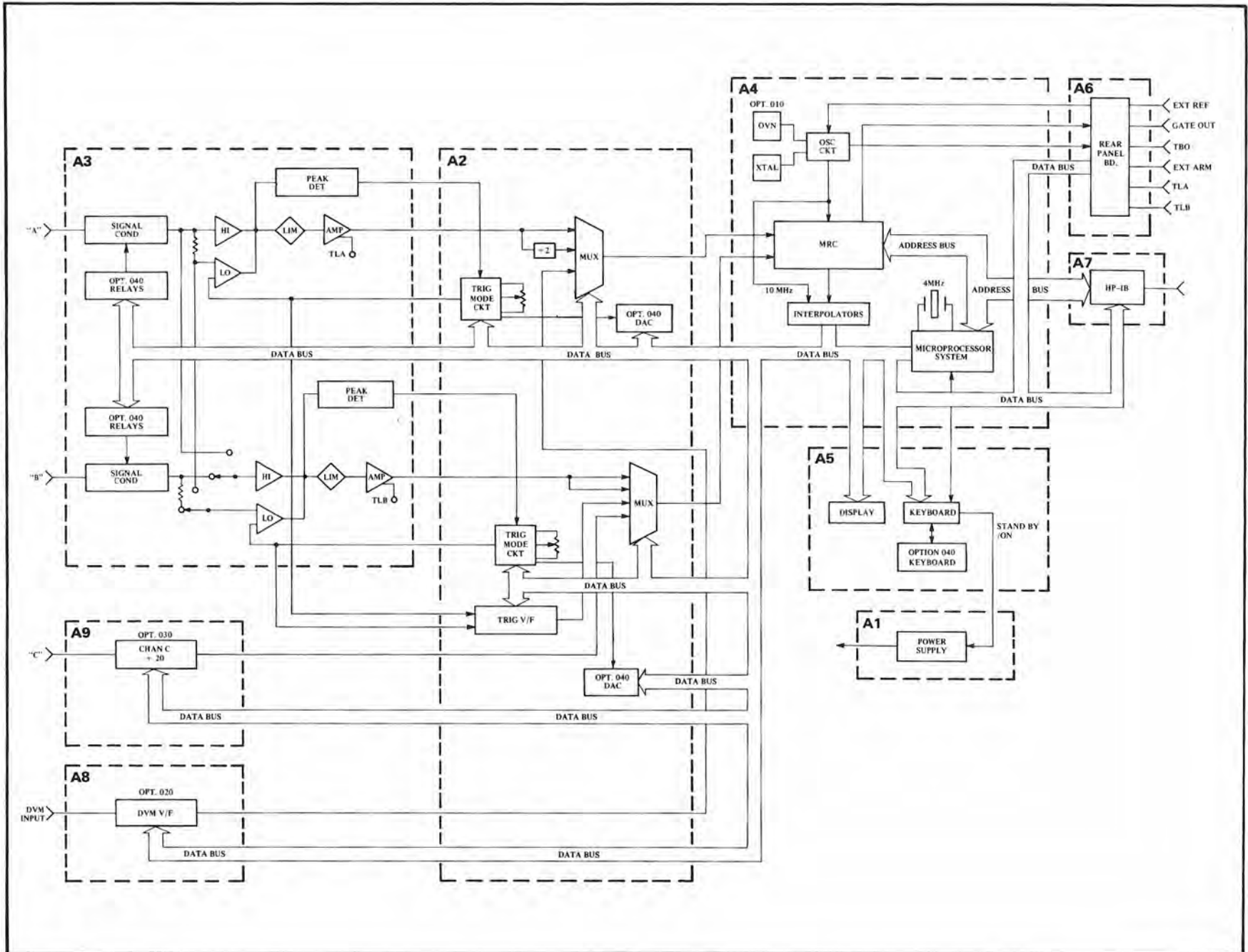

8-156. FUNCTIONAL DESCRIPTIONS OF ASSEMBLIES

8-157 A complete functional description of all individual assemblies and interaction among assemblies is given in the following paragraphs. Use the individual schematic diagrams for each assembly for reference while reading the descriptions.

8-158. A1 POWER SUPPLY ASSEMBLY

8-159. This assembly processes and provides all electrical power for the 5335A. The power transformer, T1, has multiple primary windings for several possible power line voltages from 100 volts to 240 volts at 50 to 60 Hz. The secondary of T1 has two center-tapped windings, 19 volts and 9.5 volts. AC power is provided from the 19-volt winding for the digital voltmeter, Option 020. Both secondaries have bridge rectifiers with large capacitor filters and bleeder resistors. Outputs of the bridge rectifiers are switched by the power relay K1 which is controlled by the front panel POWER switch (A4S1). The two bridge rectifier filter supplies are connected separately to the voltage regulators. Five separate regulated voltages are produced: Negative 15 volts, negative 5.2 volts, positive 15.7 volts, positive 5 volts, and positive 3 volts. A separate positive 10-volt reference voltage is produced for the internal voltmeter in A2. The ventilating fan receives power through a contact on the power relay. All of the regulators receive power through the relay which is controlled by the front panel POWER switch, S1. AC power is supplied to the Option 020 Digital Voltmeter from transformer T1 through relay K1. The five voltage regulators are linear. The positive +15.7 volt, positive 3 volt and negative 15 volt regulators are three-terminal units. The positive 5 volt and negative 5.2 volt regulators are Darlington pass transistors driven by operational amplifiers. Refer to the foldout schematic and block diagrams at the rear of this manual.

8-160. There are three levels of overcurrent protection for the power supply. First, a fuse in series with the power line protects the power transformer and all following circuits. Then a glass fuse after each of the four filter capacitors protects each power source individually from defects from the power relay and on to all the circuits of the 5335A. The third level of overcurrent protection is fast electrical sensing of the overcurrent by the regulator circuits and automatic regulation of the current output. Overvoltage crowbar protection is provided for the outputs of the positive 5 and 15 volt and negative 5.2 volt supplies.

8-161. A13 LINE MODULE

8-162. The A13 line power module schematic diagram is on the same page as the A1 power supply schematic because functionally A1 and A13 are closely related and electrically connected. External AC power is connected to the 5335A through a power cable (cord) and through the A13 line power module. The A13 module has the power line fuse, a radio frequency interference filter, and the line voltage selector printed circuit board.

8-163. A2 AMPLIFIER SUPPORT BOARD

8-164. The A2 Amplifier support board has the trigger mode and level selection circuits, trigger level voltmeter, channel selection circuits, and control data latch circuits. Refer to the foldout schematic and block diagrams at the rear of this manual.

8-165. The triggering for each input channel is determined by the trigger level selector, U2, from the four major modes of triggering available; Manual, Preset, Auto-Preset, and Auto-Adjustable. Other unique modes set trigger points to 10% and 90%, for rise and fall time measurements. Many of the triggering modes involve the channel peak detectors (on A3) which detect the voltage extremes of the incoming signal. The microprocessor (on A4) responding to operator instruction and the selected function mode sets the proper trigger level, and directs it through the trigger mode selector to the input buffer A3U4 or A3U3).

8-166. Auto-Triggering and Peak-Detectors

8-167. There are four major trigger modes used in the 5335A. The comparative signal level relationships between these modes is illustrated in Figure 8-38.

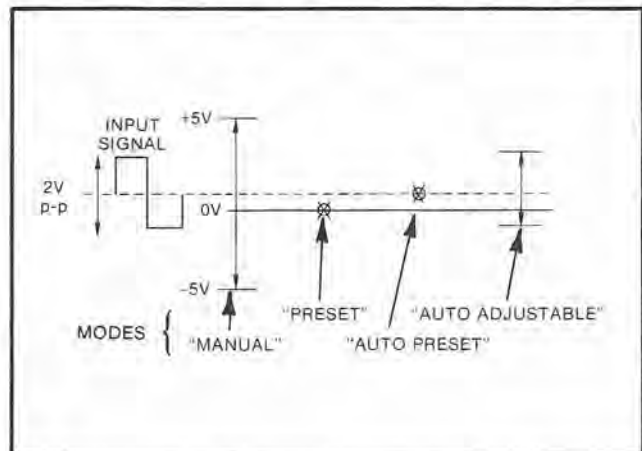

Figure 8-38. Trigger Modes Relationships

8-168. The MANUAL and PRESET modes derive the trigger level in a conventional fashion by setting the trigger level adjustment to some point between the fixed limits of negative 5 volts dc and positive 5 volts dc. The AUTO triggering modes, however, derive their trigger levels, based on the amplitude of the input signal. The AUTO PRESET mode sets the trigger level at the 50% point of the input signal, and the AUTO ADJUSTABLE mode allows selection of any level between the positive and negative peak levels of the input signal.

8-169. An essential part of the AUTO TRIGGERING modes is the operation of the peak detectors, which are used to produce dc levels, representative of the positive and negative peaks of the input signal. Using these levels, the 50%, 10%, and 90% points of the input signal can be determined. These points, totally relative to the input, are made available as trigger levels for AUTO modes. Most measurements use the 50% point. Rise and Fall measurements use the 10% and 90% points. Figure 8-39 is a simplified peak detector schematic.

8-170. A basic peak-detector consists of a diode and a capacitor. This circuit, however, presents several inherent problems; primarily the 0.6 volt drop across the diode and the nonlinear response related to the duty cycle of the input. The peak detector circuit in the 5335A compensates for these factors by providing two parallel peak detectors in a balanced configuration. One peak detector is used to compensate the other for any errors. For example, if the positive peak

of an input sine wave is at 2V, the lower detector will charge the capacitor to about $2V - V_d$. The upper detector will charge the capacitor to about $2V - 2V_d$ and pass through a unity gain buffer, to offset the lower detector buffered output. The output will be +2V, and all factors due to the diodes cancel out. There are four peak-detectors in the counter input, one for each peak of both channels. The diodes are reversed in the negative detectors.

8-171. To turn off the peak-detectors, the diodes must be back-biased. The operator switches the detectors off by pressing the AUTO TRIG key on the front panel so the key is out. This switch position is sensed by the microprocessor, which controls the auto circuitry that back biases the detectors.

8-172. The outputs of the A and B channel peak detectors are connected to either end of the trigger level adjustment pot. When AUTO TRIG is off, the ends of the pot are at +5.2 and -5.2 volts which is the Manual range of adjustment. When the AUTO mode is turned on, the ends of the trigger level adjustment control (R66) are the positive and negative peak levels of the input signal, provided by the respective peak detector. The entire range of trigger level adjustability is repositioned within the peak-to-peak amplitude of the input signal; which for most situations increases the resolution of the setting.

8-173. The Trigger Level multiplexers, controlled by the microprocessor, configure the selected trigger level mode. In the MANUAL ADJUSTABLE mode, the

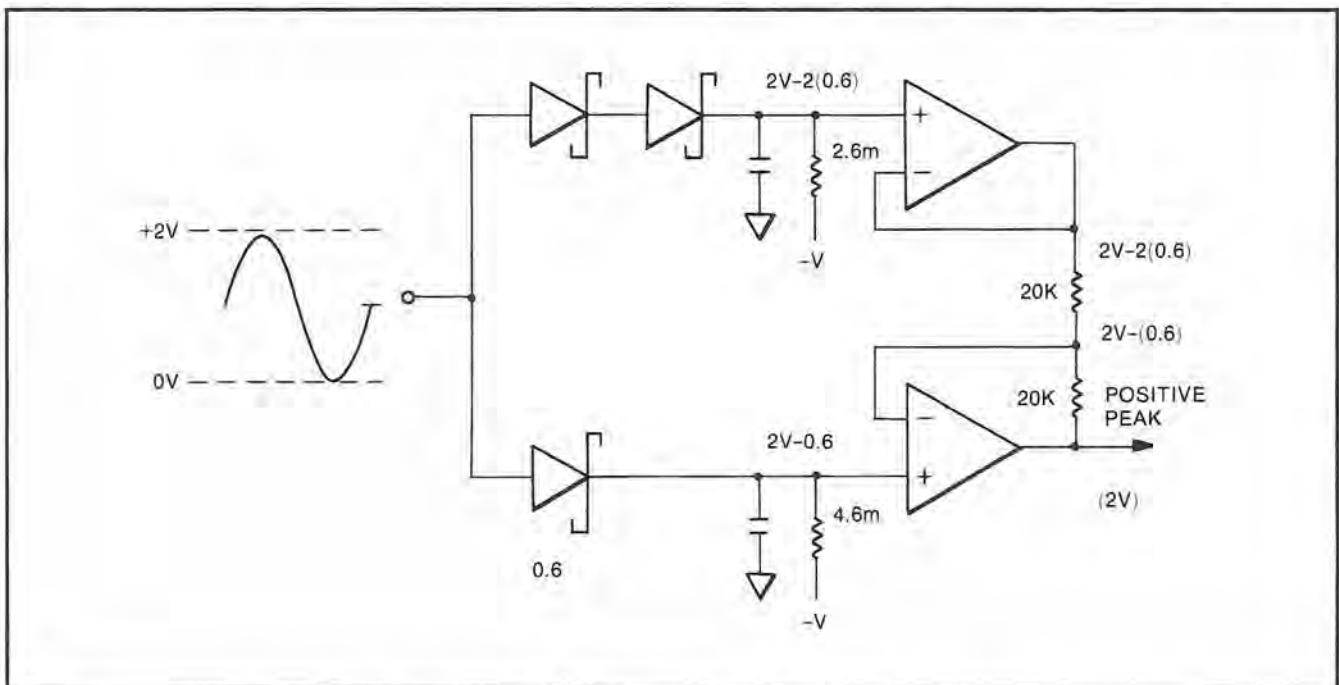

Figure 8-39. Peak Detector Simplified Schematic

trigger level goes through the Trigger Level multiplexer, then through the Auto/Man multiplexer (A2U5A) to the input level shifting buffer. The +5.2V and -5.2V levels used in the MANUAL mode are derived from circuitry that sets the peak detectors to +5.2V and -5.2V. In the AUTO ADJUSTABLE mode, the trigger level (derived from the input peak detectors) go through the trigger level multiplexer (A2U2) and then through an error integrator (A2U3), which tries to adjust the trigger level to about zero. The difference error is then routed through an analog switch to the input level shifting buffer (A3U3), which correspondingly shifts the "input signal dc level" to the error value. It is important to realize that in the 5335A, the input amplifier trigger level is always set to zero, and that it is the level of the input signal that is varied by the trigger level adjustment. In other words, instead of bringing the trigger point up to the desired trigger setting, the input signal level is brought down to the trigger point, which is always zero volts.

8-174. The other two trigger modes, PRESET and AUTO PRESET, are special cases of Manual and Auto Adjustable. For PRESET, the trigger level multiplexer selects the analog ground input. The error integrators are not used. For AUTO PRESET (the 50% point) the midpoint of the resistor divider is selected. Since the resistor divider network is tied to the peak detectors, the Error Integrators are used. The resistor divider also provides the 10% and 90% points, selectable by the trigger level multiplexer for RISE and FALL modes.

8-175. Reading Trigger Levels

8-176. The 5335A has the ability to measure its trigger levels, using an internal dedicated dc voltmeter (A2U4/U9). A single voltage-to-frequency DVM is used to measure all of the combinations of trigger levels, for both channels.

8-177. Using this arrangement, the microprocessor (A4U28) selects any one of the DC inputs to feed the voltage-to-frequency converter. The output frequency is measured by the MRC and the microprocessor calculates the proportional voltage. The calculations use three known calibration points, -5V, 0V, and +5V, derived from a precision voltage reference on the power supply assembly (+10.00V). Pressing the TRIG LVL key on the front panel directs the microprocessor to measure and display the current channel A and channel B trigger levels. The voltmeter alternately measures channel A and channel B; the display of both levels, however, appears constant.

8-178. Address Bus and Data Bus Signals

8-179. Signals on the address bus and data bus to and from the microprocessor (A4U28) and the MRC (A4U6) are use in A2 to address and control functions in A2.

8-180. A3 INPUT AMPLIFIER BUFFER

8-181. The A3 board has the A and B input signal channel amplifiers and the A and B peak detector circuits. Refer to the A3 schematic and block diagrams while reading the following paragraphs.

NOTE

The A and B input channels are basically identical circuits, but the description will only reference components in the A channel.

8-182. Inputs to the counter are received through Channel A (A3), Channel B (A3), Channel C (A9), and the DVM (A8).

8-183. The input amplifiers (Channel A and B) are a pair of high performance 200 MHz matched circuits. They have a sensitivity of 25 mV rms, and can trigger at any point between + and - 5 volts. The input signal passes through the ac/dc select circuit, (switch S10) through the 50Ω/1 MΩ select switch (S9) through the X1/X10 attenuator switch (S9) to the offset converter buffer. The selection of the COM A (Separate/Common) function is accomplished by a relay, controlled by the microprocessor (A4U28). This allows the selection of COM A either by front panel control or via the HP-IB.

8-184. The input buffer circuit is a parallel amplifier configuration. The signal is split and buffered in two parts. One part is ac coupled to a FET voltage follower (Q5), which buffers all the high frequencies (above 10 kHz). The other part is dc coupled to an Operational Amplifier (U4), which buffers the lower frequencies. The Trigger Level from the Trigger Level multiplexer is also input at this point to offset the signal. This signal is inverted, then reunited with the high frequency path. The combined signal is then passed through an emitter-follower transistor (Q8), through a protective bridge limiter (CR20-CR22) to the Schmitt-Amplifier (A3U5). The Schmitt-Amplifier is a high performance, 500 MHz band width device with settable hysteresis and a built-in three-state trigger light circuit. The square wave output of the input amplifier is then level-shifted to ECL, and sent to the A2 board.

8-185. The peak detector circuits on the A3 board are described in paragraph 8-166.

8-186. A4 MAIN LOGIC BOARD

8-187. The A4 board has the microprocessor system, the multiple register counter (MRC), time base oscillator, and the interpolator circuits. Refer to the A4 schematic diagram.

8-188. The 5335A is based on microprocessor architecture. It uses a Motorola MC6802 microprocessor (U28), which has a built-in clock circuit and 128 bytes (8 bits by 128 words) of read/write memory (RAM). Supporting the microprocessor are two 65K-bit ROMs (U22, U23) that form approximately 16K bytes of program storage area. There is an additional 256 bytes of program RAM provided by two 1K-bit static memories (U25, U26) used to provide buffering and address decoding. The microprocessor, directed by the permanently stored program routines (in ROM), actively controls the overall operation of the counter. It monitors for interrupts and for operator instructions, either through the front panel keyboard or the HP-IB, and directs the appropriate circuit configurations. It retrieves data, performs all the necessary mathematical computations, and displays the results.

8-189. The RESET circuit for the microprocessor is designed to give a several millisecond pulse whenever the +5 volt power is switched off. Reset occurs even for extremely quick power ON-OFF-ON sequences. The reset pulse is active low. The timing circuit which determines the length of the reset pulse is C42 and R43. Transistors Q10 and Q11 are a Schmitt trigger that supplies the fast RESET pulse to the microprocessor, to U28 and to the A7 HP-IB interface.

8-190. The desired output(s) of the channel A and B signal multiplexers are selected by the microprocessor, level-shifted (to MRC specific logic levels) and input to the MRC as channel A and channel B, respectively.

8-191. Operation of the counter centers on the interaction between the microprocessor system and the MRC. The MRC is a large-scale-integration, bipolar, integrated circuit utilizing both emitter-function logic and integrated-injection logic. It is a programmable, universal, counter-on-a-chip, containing four sets of registers: Events, Time, Status, and Control. The E (Events) and T (Time) registers collect the raw input measurement data. The S (Status) register includes E and T register overflow flags and information on the state of the measurement. The C (Control) register,

directed by the microprocessor sets up the various measurement modes of the MRC, and resets the counters, synchronizers, and overflow flags. The MRC has inputs for Channels A, B, C, a time base, and an external arm signal. Outputs include two gate status lines, two interpolator lines, and a register reset line. When a measurement is completed, the MRC signals the microprocessor by pulling the IRQ (Interrupt Request) line. Using the accumulated Events and Time data, the microprocessor can then calculate the selected function mode measurement. For example, dividing the contents of the Events register by the contents of the Time register produces the frequency of the measurement. Likewise, dividing T by E yields Period, and Time Interval uses the contents of T directly.

8-192. The measurement gate time is dictated either by the microprocessor or by a one-shot under front panel control. The time constant for the specified measurement time has two ranges; NORM, nominally 20 milliseconds to 4 seconds, and FAST, 100 microseconds to 20 milliseconds. Gate Times are continuously adjustable (as opposed to decade steps) through these ranges and the microprocessor automatically includes gate time in its calculations. A buffered TTL level output is provided to the rear panel representing the gate signal. The Gate open and Gate closed signals from the MRC are combined in an EXCLUSIVE OR gate (A4U30) to produce a $\overline{\text{GATE OUT}}$ signal. This signal is high when the gate is closed and low when the gate is open.

8-193. The MRC is fully synchronous with both the input and the time base. A "triple" synchronization circuit is used, which means that, with the use of interpolators, the exact gate time of a measurement is used for computations.

8-194. Interpolator Technique

8-195. A major feature of the 5335A is the pulse count interpolators. By using interpolators the inherent one count error is effectively reduced by a factor of 200. The basic principle is to detect the slight error factor, and then proportionally expand it (200X) to a time length which can be measured by the counter. Then, by using known calibration pulses, the actual error factor can be interpolated. The error is then effectively cancelled by compensating the MRC's adjustable gate time. The use of interpolators allows measurements to be resolved to near one nanosecond. Refer to *Figure 8-40*.

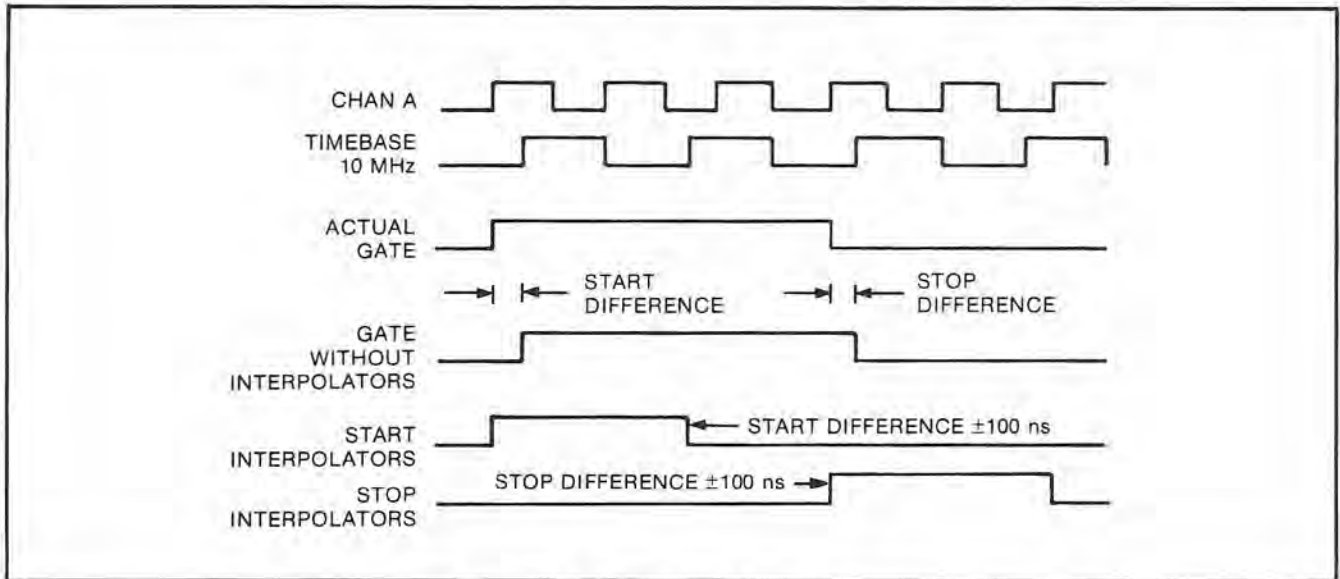

Figure 8-40. Interpolator Timing Diagram

8-196. Without interpolators, the gate signal during a measurement would normally be synchronous with the main clock (time base). The slight time difference between the actual events of Channel A triggering, and the opening and closing of the gate, would represent an unrecoverable error factor, limiting the accuracy of the measurement. The start and stop interpolators within the 5335A provide a method of determining the amount of time error (for both start and stop events) and adjusting the microprocessor gate time factor to compensate.

between channel A trigger events and the time base. To measure these pulses, a dual slope integration scheme is used. Basically, the short interpolation pulse, from the MRC, is used to rapidly charge a capacitor, via a constant current source. When the pulse ends, the capacitor begins a scaled discharge at about 1/200th the charge rate. This proportionally expands the interpolator error pulse by a factor of 200X. This integrated waveshape is then squared and used to gate a time base signal into the interpolator counter. The count in the counter will proportionally reflect the length of the interpolator pulse. Refer to Figure 8-41.

8-197. The MRC provides start and stop interpolator pulses, representing the time difference (error factor)

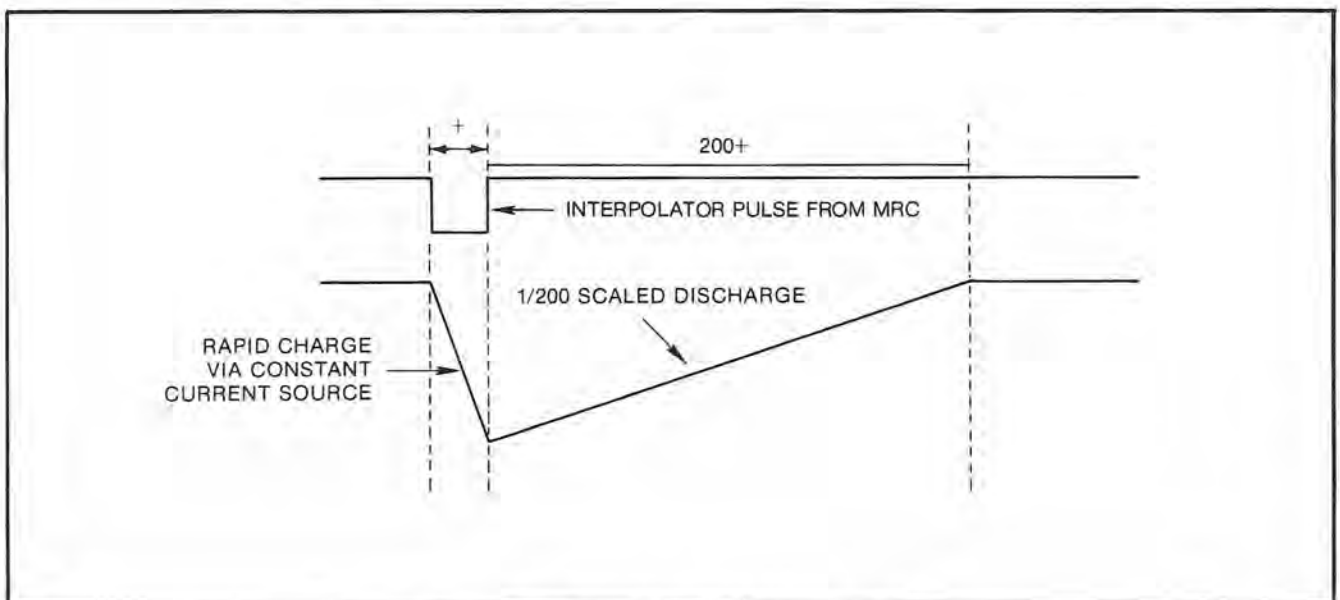

Figure 8-41. Expanded Interpolator Error Pulse

8-198. To convert the count in the interpolator counter to real nanoseconds, the MRC provides two calibration pulses; a short calibration pulse of 100 ns and a long calibration pulse of 200 ns. By inputting each of these known length pulses into the same integrator and noting the number of counts produced, a mathematical proportion is established, with which the true time for any pulse length can be interpolated. For example, if the short (100 ns) calibration pulse produced 200 counts, and the long (200 ns) calibration pulse produced 400 counts, a pulse of 150 ns would produce 300 counts. Inversely, if 300 was the number of counts accumulated during the interpolator pulse integrator cycle, then the error factor would be 150 ns. Refer to *Figure 8-42*.

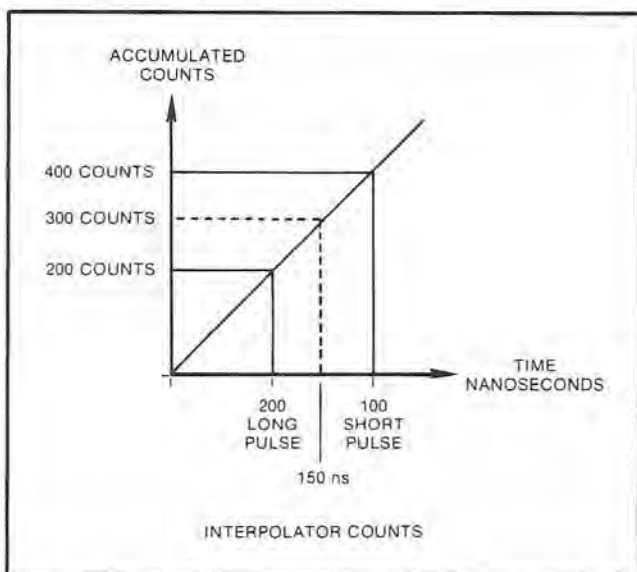

Figure 8-42. Short and Long Calibration Pulses Example

8-199. The final equation for determining the actual gate time is:

$$\begin{aligned} \text{GATE TIME} &= (\text{Counts in T-register}) \times 100 \text{ ns} \\ &+ \frac{\text{Count X} - \text{Count S}}{\text{Count L} - \text{Count S}} \times 100 \text{ ns} \\ &\quad \text{(for the Start Interpolator)} \\ &- \frac{\text{Count X} - \text{Count S}}{\text{Count L} - \text{Count S}} \times 100 \text{ ns} \\ &\quad \text{(for the Stop Interpolator)} \end{aligned}$$

where:

Count X = effective counts from interpolation pulse
 Count S = effective counts from short calibration pulse
 Count L = effective counts from long calibration pulse

For example, given the following values:

Count in MRC T register = 10
 Count from Start Interpolator = 100 (+256)*
 Count from Stop Interpolator = 230
 Count from short calibration pulse = 200
 Count from long calibration pulse = 150 (+256)*

$$\begin{aligned} \text{GATE TIME} &= (10 \times 100 \text{ ns}) + \frac{356 - 200}{406 - 200} \times 100 \text{ ns} - \frac{230 - 200}{406 - 200} \\ &\times 100 \text{ ns} = 1000 + 75.7 - 14.6 = 1061.1 \text{ ns} \end{aligned}$$

***NOTE**

Any count less than 200 is increased by 256 to compensate for overflow of the eight-bit counter at 255.

8-200. If this were a time interval measurement, the microprocessor would be able to tell you the exact answer to about one nanosecond accuracy. In actual measurements the interpolators will yield different counts, other than the 200 and 400 counts indicated here.

8-201. The general measurement program routine is to make a measurement, read the MRC registers, read the interpolator counters, perform the calculations, and display the results. In between measurements, the MRC registers and the interpolator counters are reset.

8-202. The standard time base for the MRC is a 10 MHz crystal oscillator (A4U2B). Additionally, provisions are made to allow for an optional high-stability ovenized oscillator (e.g., HP 10811A). The microprocessor has its own associated oscillator, which generates an approximate 4 MHz clock. This signal is divided to 1 MHz within the microprocessor, and output to the counter as the main enable clock. All timing parameters within the counter are referenced to this clock.

8-203. Either 5 or 10 MHz signals may be used as an external reference. An external reference buffer circuit (U2A & U1) accepts any submultiple of 10 MHz, and outputs a 10 MHz frequency. The buffer automatically determines whether or not the input has enough amplitude to be used.

8-204. The switching between the internal and external time base signals is automatic. Whenever an external reference is connected to the rear panel TIME BASE IN connector, an external reference detector (U2A) circuit senses the signal and configures the time base multiplexer to pass the external signal instead of the local oscillator. The output of the external reference detector also goes to the microprocessor, which prompts the microprocessor to turn on the front panel EXT TIME BASE annunciator and send the status to any devices on the HP-IB. The selected time base is also buffered and provided to the rear panel for an auxiliary TIME BASE OUT connector.

8-205. A5 KEYBOARD AND DISPLAY

8-206. The A5 board has the visual output display and the operator control pushbutton keys. Refer to the A5 schematic diagram.

8-207. The DISPLAY assembly receives already decoded segment data from the microprocessor, latches it and inputs it to three LSI display IC's (U1, U2 and U7). These IC's then output the data, scanning the display with self-contained strobe circuitry. All information from the keyboard is transferred to the microprocessor through an interrupt scheme. The front panel keys are arranged into a matrix. In the quiescent state, no regular scanning of the matrix is performed. However, when a key is pressed, an interrupt line to the microprocessor is activated. The microprocessor scans its I/O bus and identifies the keyboard. It then performs a subroutine that scans the keyboard matrix, and responds to whatever key was pressed. If no key, or more than one key is found pressed, the program ignores the interrupt.

8-208. A6 REAR PANEL BOARD

8-209. THE A6 board has five separate functions associated with six connectors: J6 is $\overline{\text{GATE OUT}}$, J1 and J4 are TRIGGER LEVEL OUT A and B, J5 and J2 are TIME BASE IN and OUT, J3 is EXTERNAL ARM IN, and two switches EXTERNAL ARM START and STOP. (Refer to section III for details of uses of these functions.)

8-210. An amplifier (Q4-Q5) level shifts and buffers the $\overline{\text{GATE OUT}}$ signal from the MRC on A4. The TTL $\overline{\text{GATE OUT}}$ signal is available for external use.

8-211. A signal from other equipment may be applied to the EXTERNAL ARM IN connector to enable circuits in the 5335A. Amplifier Q1-Q2 isolates this signal. The EXTERNAL ARM input, in conjunction with a pair of three-position switches (S1 and S2), allows external arming of the start and/or stop of a measurement. The TTL EXT ARM input is buffered and converted to MRC-compatible logic levels, and directed to the MRC. The MRC internally compensates for external arming. Although externally armed, the measurement does not start or stop until an input signal is received.

8-212. The TRIGGER LEVEL OUT signals from the A and B input channels are available for external use at J1 (channel A) and J4 (channel B).

8-213. The TIME BASE IN (J5) connector allows an external signal to be used to control the timing of the 5335A counter, and the TIME BASE OUT connector

(J2) provides the internal time base signal for use to external equipment. If the optional oven (temperature-controlled) oscillator is in the 5335A, the signal at the TIME BASE OUT connector would be derived from the Option 010 high quality oscillator.

8-214. A7 HEWLETT-PACKARD INTERFACE BUS BOARD

8-215. The A7 HP-IB Board serves to interconnect the 5335A and an external controller, via the Hewlett-Packard Interface Bus. The circuitry includes bus buffers, decoding ROMS and an LSI HP-IB interface IC. These circuits perform the handshake and interpret commands, data, interrupts.

8-216. The HP-IB interfaces with the A4 microprocessor system through A7U1 with an eight-bit bidirectional bus, a chip-select line, a Read/Write line, a Reset line, three register select lines, interrupt request line, two DMA control lines, and an address switch enable line. The microprocessor system on A4 controls HP-IB interface with commands to A7U1.

8-217. The HP-IB signals interface with the 5335A through the A14 assembly directly to A7, the HP-IB Logic board. The 16 HP-IB signals pass through individual transceivers. Four quad-bidirectional IC's U3, U4, U6, and U7 accommodate all 16 lines. Direction of data flow is controlled by three-state disabling of the undesired direction element. With power off the 5335A does not load the HP-IB. "HP-IB" is the implementation by Hewlett-Packard of the IEEE 488-1978 "Digital Interface for Programmable Instrumentation". Hewlett-Packard and many other sources have literature about IEEE 488-1978.

8-218. A14 HP-IB CONNECTOR BOARD

8-219. The A14 HP-IB Connector Board schematic is on the same page with A7 board because two assemblies are directly related and physically connected. The A14 board connects the HP-IB functions to external equipment on the HP-IB, and allows the HP-IB address of the 5335A to be set as desired.

8-220. A8 DIGITAL VOLTMETER BOARD

8-221. The A8 board has the optional (020) Digital Voltmeter circuit for the 5335A.

8-222. The Digital Voltmeter input passes through U11, a buffer amplifier, then a programmable gain select (Q4-Q6), controlled by the microprocessor, through a multiplexer (U7) to a voltage-to-frequency converter (U6). The dc level is compared to a voltage

reference (U4–U5), and converted to a pulse train with frequency proportional to the input voltage. The output of U2 is then buffered and routed to the Channel A Signal multiplexer in A2 or A11, and eventually to the MRC (A4U6), where it can be counted, interpreted and sent to be displayed as a voltage. Data signals from the microprocessor are clocked through U3 and the optic-isolators U9, U10, U12 and U13 to control the gain (attenuation) select transistor, Q4–Q6. The Input Logic Switching Control circuitry consists of A8U3 register, that latch four bits from the microprocessor controlled data bus, U9, U10, U12, U13 optic-isolators, and A8Q2, Q3, and Q7, which decodes and provides range selection information, as well as control bits for U7, the reference multiplexer. A8U4 and A8U5 provide the +5V, Ground, and –5V references to the input of A8U7 multiplexer. The microprocessor utilizes these three voltage references to compute the unknown input voltage. The U7 control bits originate in U9 and U10 optic-isolators. The Voltage-to-Frequency converter circuit is composed of A8U6 V-to-F, U8 unity gain buffer, C12 the integrating capacitor, C8 the one-shot capacitor, and U2 optic-isolator converts the floating frequency output to a chassis-referenced output). Transformer T1 (1:1 ratio), full wave rectifier CR1, and U1 dual-tracking regulator, form the floating power supply of A8.

8-223. A9 CHANNEL C INPUT AMPLIFIER BOARD (OPTION 030)

8-224. The A9 board has the optional third input amplifier with a 1.3 gigahertz upper frequency range limit.

8-225. The channel C input signal passes through a fused input BNC connector, through a protective limiter (CR8, CR9, CR11, and CR12) to the pin diode attenuator (CR1–CR4). This attenuator provides a nominal amount of control of input SENSITIVITY, with the front panel control. The output of the attenuator feeds the broadband amplifier, U1. The output of the amplifier is divided by 20, by a decade divider (U2) and a binary divider, U3. This prescaled signal is then routed to the channel B signal multiplexer. A peak detector and Schmitt trigger (U4) are used to effectively disable the channel C output (by U3) whenever the peak detector level is below the threshold level. The microprocessor enables the channel C through a flip-flop (U5) which clocks the U3, allowing the prescaled signal to pass.

8-226. A10 SWITCH PANEL (OPTION 040)

8-227. The A10 switch panel has the 12 front panel INPUT control switches and corresponding lights to

indicate active functions. Refer to the A10 schematic diagram while reading the following paragraph.

8-228. The A10 board switches connect to the A5 keyboard display which passes A10 switch activation conditions through to the 5335A data and address buses. The 12 pushbutton switches are momentary contact single-circuit components. The microprocessor system on A4 indirectly responds to the closure of a pushbutton switch and commands a corresponding relay on the A12 Programmable Input Amplifier.

8-229. A11 AMPLIFIER SUPPORT BOARD (OPTION 040)

8-230. The A11 amplifier support board has circuits for trigger mode selection, trigger level selection, channel selection, trigger level voltmeter, control data latching, and digital-to-analog conversion.

8-231. Trigger level source is selected by the trigger level selector (U2), from the four major modes of triggering available; Manual, Preset, Auto-Preset, and Auto-Adjustable. Other unique modes set trigger points to 10% and 90%, for rise and fall time measurements. Many of these triggering modes involve the A12 peak-detectors, which detect the voltage extremes of the incoming signal. The microprocessor, responding to operator instruction and function mode, selects the proper trigger level, and directs it through the trigger level selector (U2) to the A12 input buffer. The trigger levels for both channels are also directed through a dedicated trigger level DVM (U4, U10), and input to the channel B signal multiplexer (U7).

8-232. The two digital-to-analog trigger level converters (U23 and U21) are used to produce the trigger levels for channels A and B under two conditions. First: when the 5335A is under HP-IB control, the trigger level is programmed through the A4 microprocessor to the trigger level data latches (U16, U17, U24). Digital trigger level data from U16, U17, and U24 is applied to U21 and U23 which convert the data to analog voltages, passed through U22A or U22C to U5, the trigger level selector. Second: when the 5335A is under internal ROM diagnostic control, the trigger level is programmed by the microprocessor to the data latches (U16, U17, U24). And digital trigger level data is applied to U21 and U23, converted and passed to U5.

8-233. Relays K1 through K9 on the A12 board are actuated by the relay driver transistor pairs A11Q1–Q18. The relay drivers receive command data through transfer latch U18. Command data for the relay drivers originates in the microprocessor on A4.

8-234. A12 PROGRAMMABLE INPUT AMPLIFIER (OPTION 040)

8-235. The A12 Input Amplifier is an optional replacement for the A3 Input Amplifier. The A12 unit has all the capabilities of the A3 unit and added capability to have every function be remotely programmed. The A12 board has the A and B input signal channel amplifiers and the peak-detector circuits.

NOTE

The A and B input channels are basically identical circuits, but this description will only reference components in the A channel.

8-236. The A and B input channels are a pair of high-performance 200 MHz amplifiers. They have 25 mV rms sensitivity, and can be triggered at any point between ± 5 volts. The input signal passes through the relay-controlled (K9) ac-dc coupling selection circuit, then through the relay-controlled (K6) 1 M Ω /50 Ω input impedance selection circuit, then through the relay-controlled (K8) X1/X10 attenuator, then through the relay-controlled (K7) input low-pass filter. The relay-controlled (K4) separate/common circuit is between the attenuator and filter circuits.

8-237. The relays (K1-K9) that switch nine functions on A12 are controlled by the A4 microprocessor system through the data and address buses. In turn the microprocessor system receives pushbutton commands to control the relays from A10 (the Option 040 switch panel) through A5 the, keyboard display.

8-238. The input buffer circuit is a parallel amplifier configuration. The signal is split and buffered in two parts. One part is ac coupled to a FET voltage follower (Q8), which buffers all the high frequencies (above 10 kHz). The other part is dc coupled to an Operational Amplifier (U4), which buffers the lower frequencies.

The Trigger Level from the Trigger Mode multiplexer is also input at this point to offset the signal. This signal is inverted, then reunited with the high frequency path. The combined signal is then passed through an emitter follower (Q9), through a protective bridge limiter (CR25-CR30) to the Schmitt-Amplifier. The Schmitt-Amplifier is a high performance, 500 MHz band width device with settable hysteresis and a built-in three-state trigger light circuit. The square wave output of the input amplifier is then level-shifted to ECL, and sent to the A11 board.

8-239. A15 TEMPERATURE-CONTROLLED 10 MHz TIME BASE OSCILLATOR (OPTION 010)

8-240. The optional A15 temperature-controlled oscillator is described in a separate publication supplied with 5335A counters that include this option.

8-241. TROUBLESHOOTING (FAILURE ANALYSIS)

8-242. Troubleshooting or failure analysis of the 5335A as given in this manual includes built-in-diagnostics, conventional specific tests, and signature analysis.

8-243. The built-in diagnostics are stored in read-only-memory (ROM) integrated circuits. Complete instructions for using the diagnostics are given in this section. *Table 8-6* is a list of the built-in diagnostics.

8-244. Conventional specific tests for troubleshooting the assemblies in the 5335A are given in this section. The phrase "Signature Analysis" refers to an efficient system of digital electronic equipment troubleshooting available for the 5335A. More information about signature analysis is available from your Hewlett-Packard sales and service office. "Signatures" for many points in the 5335A circuits are given in this service manual.

Table 8-6. Diagnostics

| DIAGNOSTIC # | DESCRIPTION | COMMENTS |
|--------------|--------------------------------------|--------------------------------|
| 0 | SUPERCHECK | |
| 1 | (SCALE = 0 AUTOSETS TO 1) | |
| 2 | STIM MODE OF SIGNATURE ANALYSIS | |
| 3 | SETS FRONT END CONTROL TO 0'S | ← { programmable input version |
| 4 | SETS FRONT END CONTROL TO 1'S | |
| 5 | DISPLAYS FRONT END SWITCH DATA | |
| 6 | DISPLAYS REAR SWITCH GROUP DATA | |
| 7 | DISPLAYS HP-IB ADDR SWITCHES | |
| 8 | PROD TEST OF ALL SWITCHES | |
| 9 | DOES SHORT CHECK OF MRC | |
| 10 | DOES EXTENDED CHECK OF MRC | checks overflow bit |
| 11 | INTERPOLATE LONG, NO DISPLAY (FAST) | |
| 12 | INTERPOLATE SHORT, W/DISPLAY | |
| 13 | INTERPOLATE LONG, W/DISPLAY | |
| 14 | CHECKS FRONT END USING TIME BASE OUT | |
| 15 | URNS ON ALL DISPLAY ANNUNCIATORS | |
| 16 | DISPLAYS THE HP-IB ADDRESS | |
| 17 | DISPLAYS KEY # (OPER-CODE) | |
| 18 | TWEEK DACS TO ZERO | |
| 19 | TWEEK DACS TO -5.12V | |
| 20 | DVM MUX = -5V REF | ← DVM V-F |
| 21 | DVM MUX = GND REF | |
| 22 | DVM MUX = +5V REF | |
| 23 | DVM MUX = INPUT, RANGE = LOW | |
| 24 | DVM MUX = INPUT, RANGE = MED | |
| 25 | DVM MUX = INPUT, RANGE = HIGH | |
| 26 | TRIG DVM = -5V REF | |
| 27 | TRIG DVM = GND REF | |
| 28 | TRIG DVM = +5V REF | |
| 29 | TRIG DVM = TRIG A INPUT | ← { AUTO TRIG must be OUT |
| 30 | TRIG DVM = TRIG B INPUT | |
| 31 | TRIG DVM = +5 VOLT SUPPLY | |
| 32 | TRIG DVM = +3 VOLT SUPPLY | |
| 33 | TRIG DVM = -5.2 VOLT SUPPLY | |
| 34 | INCREMENTAL TESTING OF DACS | |

NOTE: All DIAG volts read in (volts) with "RANGEHOLD" off and read in V/F frequency out (Hz-volts) with "RANGEHOLD" on.

8-245. BUILT-IN DIAGNOSTICS

8-246. Introduction

8-247. The 5335A Universal Counter is a microprocessor-based system with 34 built-in diagnostic subroutines. These diagnostics can be used for automatic testing, and as an aid in troubleshooting the 5335A. Most of the diagnostic subroutines are used in a SUPER-CHECK routine. They can also be accessed directly for testing and troubleshooting of a specific section of the counter. A combination of diagnostic subroutines can be used to isolate a faulty section or

group of components within the 5335A. Once the 5335A has been set in the diagnostic mode, switching from one diagnostic to another may be as simple as keying in the desired diagnostic number, with the exception of three diagnostics. (i.e., to exit Diagnostic #2, Diagnostic #6, and Diagnostic #17, you must cycle the 5335A power switch to STBY and back ON again.)

8-247. Accessing the Built-In Diagnostics

8-248. To access the built-in diagnostics from the front panel, there are certain conditions that must be met:

First, it is necessary to verify the proper operation of the **KERNEL**. The **KERNEL** is the heart of the system, the minimum hardware that must be functioning properly to operate the system. The **KERNEL** of the 5335A Universal Counter is the microprocessor (A4U28), the ROMS (A4U22 and A4U23), the RAMS (A4U25 and A4U26), the bidirectional buffers (A4U16 and A4U24), and the buffer (A4U27). (To verify the proper operation of the **KERNEL**, start with the POWER-UP SELF-CHECK, refer to paragraph 8-322.)

Second, the Address and the Data bus lines must not be shorted.

Third, the front panel display and keyboard must function properly.

Fourth, the power supplies and the microprocessor oscillators must be within specifications.

8-250. After successful completion of the POWER-UP SELF-CHECK, the 5335A must be set in the diagnostic mode. This is done by calling up Special Function 99. To call up Special Function 99 press the 5335A keys: SCALE, SMOOTH, 99, ENTER. To address a specific diagnostic, press: SCALE, the diagnostic number, and ENTER. Make sure the SCALE key lamp flashes after it is pressed. The noncyclic diagnostic sub-routines can be reenabled by simply pressing RESET.

8-251. Any failures during the power-up cycle will disable the counter and produce one of the following:

- a. A blank display.
- b. A hieroglyphic is displayed.
- c. Display shows a missing segment or digit.
- d. Numbered ERROR or FAIL message is displayed.

NOTE

The fail messages are displayed in a continuous loop, and generally indicate a hardware related problem. Error messages indicate that the user has attempted an improper operation, either through the keyboard or the HP-IB. *Table 4-1* lists the Error Messages, and *Table 4-2* lists the Fail Messages.

8-252. Shaded Block Diagrams

8-253. Simplified block diagrams with some gray areas are interspersed with the numbered diagnostic tests. The white (not-shaded-gray) areas on these diagrams indicates which sections of the 5335A are tested by the associated numbered diagnostic. Conversely, the gray-shaded sections on the block diagram indicates which parts of the 5335A are NOT tested by the associated numbered diagnostic test.

8-254. DIAGNOSTIC #1 "SUPER CHECK"

NOTE

The 5335A rear panel TIME BASE OUT BNC connector must be connected by cable to the front panel INPUT A connector.

8-255. This diagnostic exercises a large portion of the 5335A Universal Counter. First, the microprocessor must be functioning properly. If it is not, the display may be blanked, a hieroglyphic may be displayed, or the 5335A will not respond to the front panel keys. If this is the case, the microprocessor can be tested using the Signature Analysis troubleshooting technique, with the microprocessor set in the FREERUN MODE. Refer to paragraph 8-408, Signature Analysis of the Microprocessor, for the FREERUN procedure. (See *Figure 8-60*, Troubleshooting Flowchart, for further information concerning display types and possible failure messages.)

NOTE

For Signature Analysis troubleshooting, ensure that the 5335A is NOT connected to the HP-IB bus.

8-256. Second, the ROMS (A4U22 and A4U23) are tested by the microprocessor, using a CHECKSUM. Each 8K ROM is divided into four 2K blocks. The 16-bit CHECKSUM is stored in the first two bytes of each 2K block. The CHECKSUM represents the correct arithmetic sum of the rest of the bits in each 2K block. The microprocessor adds all the words stored in the remaining bits of each 2K block and compares this with the CHECKSUM. If the resulting sum does not

match the CHECKSUM, FAILURES 1.0 → 1.9 will be displayed, or the 5335A display will be blanked. Refer to paragraph 8-406 for the Signature Analysis of the ROMS.

8-257. If no failure is indicated at this point, there is a high probability that A4U28 (microprocessor), A4U22 and A4U23 (ROMS), A4U24 and A4U27 (buffers), and A4U21 and A4U10 are functioning properly.

8-258. The next test performed is on the RAMS. They are tested for their ability to be written to and read from. The 5335A contains two RAMS, the microprocessor on-board RAM (internal to the 6802 microprocessor) and the U25/U26 RAM. When the same bit pattern that was written is not read back, FAILURES 2.0 → 2.2 will be displayed, the display will be blank, or a hieroglyphic could be displayed. If any of these failures are displayed by the 5335A, refer to paragraph 8-410 for the Signature Analysis of the Output Ports. The procedure given in paragraph 8-410, uses the RAMS to write the stimulus pattern for “key signature” troubleshooting in the A4 Main Logic Assembly, A5 Keyboard and Display Assembly, A7 HP-IB Logic Assembly and in the A8 DVM Assembly.

8-259. The microprocessor then proceeds to test the front panel display board which includes the annunciators, the momentary switches, the switch LED's, and the front panel display LED's. All display and annunciator lamps turn on for about one second. Visual failures such as a defective seven-segment-display, key lamp, or display annunciator will be detected during this portion of the test.

8-260. Next, the Data Bus is checked in two ways. First a ground signal is forced through Data line six (D6). The microprocessor sets up the conditions for A4U20(12) to enable A4U16 and A4U10. In turn A4U10 enables A4U19. Then A4U19(15) enables A4U15, which sets up the ground signal, and forces the signal onto D6. Data line six sends the signal through A4U16 and A4U24 and back to the microprocessor. The second part of the check is done by reading the Data Bus at the output of the Interpolator Counters which were reset by the MRC [A4U6(29)]. Errors 3.1 through 3.3 will be displayed if the microprocessor does not receive the given expected conditions. The procedure in paragraph 8-410 should isolate any problem developed while performing this test.

8-261. The proper internal operation of the MRC is verified next. The Status, Events and Time registers are

thoroughly tested, (i.e., reset condition, end-of-measurement status, and their overflow conditions). Bidirectional buffer A4U7 is also tested in conjunction with the MRC. Any 4.X failure displayed indicates a faulty MRC or a defective A4U7.

8-262. The next block of circuitry tested is the START and STOP interpolators. The MRC generates a set of calibrating pulses and a Reset pulse. The calibrating pulses are used for testing the Charge and Discharge current sources and A4U4 and A4U5. The Reset pulse resets the interpolator counters at the end of each measurement test. A4U6, A4U4, A4U5, A4U8, A4U9, A4U13, A4U14, and the interpolator circuits are tested in this section. If a failure occurs at this point in the test, checkout the START and STOP interpolators by referring to paragraph 8-415.

8-263. The internal Trigger Level Voltmeter in the Amplifier Support Assembly (A2) is tested next. The +5V, 0V and -5V references are read through A2U4 (selected by A2U15), and converted to a frequency in A4U9, then level shifted by A2U8. The signal is then selected by A4U7 the multiplexer, and again level shifted by A2U6 into the MRC. Failures 6.1 through 6.3 will be displayed if these circuits do not function properly.

8-264. The next major test is performed on the 5335A Front End. The Time Base Out (TBO) must be connected to INPUT A. The presence of the signal in Channel A is sensed (if no signal is present at INPUT A, ERROR 7.0 is displayed), then the accuracy of the applied signal is checked, the COM A/SEP relay is checked in SEP and then in COM A (the presence and accuracy of the signal in Channel B is verified), then the Channel A prescaler is tested (A2U11 and A2U7). Failures 7.1 through 7.5 will be displayed if any malfunction is detected at this time. An “FE PASS” message will be displayed if all the above tests are successfully completed.

8-265. Three supplies are checked next in the A2 Amplifier Support Assembly. The +5V by A2U4(2,6), the +3V by A2U4(12) and the -5.2V by A2U2(3). These voltages are converted into their equivalent frequencies by A2U9 then routed through A2U8, A2U7, and A2U6 the MRC. Refer to paragraph 8-338 for the power supplies nominal voltages and their tolerances.

8-266. The whole procedure is then repeated, looping back to check the ROMS again. Refer to *Figure 8-43*, Diagnostic #01 Shaded Block Diagram.

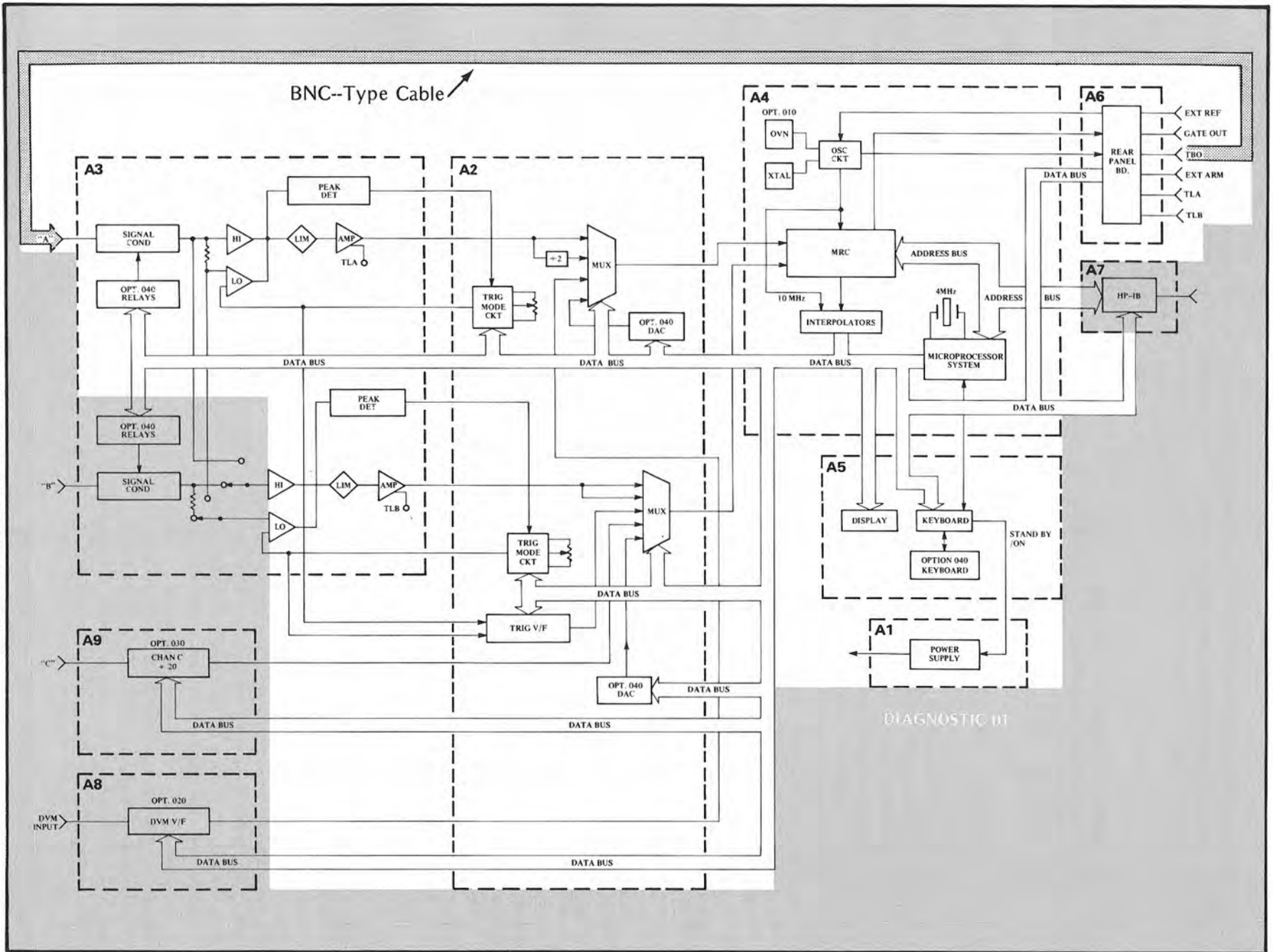

Figure 8-43. Diagnostic #01 Shaded Block Diagram

8-267. DIAGNOSTIC #2: SIGNATURE ANALYSIS STIMULUS MODE

8-268. This diagnostic procedure is designed to test all the output ports of the microprocessor system. They are:

Gate Range – Output Control Flip/Flops, A4U11 and U18

Keyboard – Display Control latch, A5U4

Keyboard – Display Data latch, A5U5

HP-IB Data Output port, A7U1, U4, U7 and A14J3

DVM option Control latch, (A8U3)

8-269. The Signature Analysis Stimulus Mode can be evoked through software (via the front panel keys) or by hard-wire (using a jumper wire on A14). Paragraph 8-410 describes the procedures for activating the Signature Analysis Stimulus Mode, and provides the expected output port signatures. Refer to *Figure 8-44*, Diagnostic #02 Shaded Block Diagram.

NOTE

To exit this diagnostic the 5335A POWER switch must be cycled to STBY and back to ON.

8-270. DIAGNOSTIC #3 AND #4: FRONT END LATCH CONTROL TEST

8-271. These diagnostic subroutines are designed to aid in the troubleshooting of the Front End Latch Control IC's A2U15 and U12 and related circuitry, including A3K1 in the standard front end.

8-272. They are also used to troubleshoot the latches of the programmable front end input (Option 040), A11U16, U17, U18, and U24 and the related circuitry, including A12K1 through K9.

8-273. Diagnostic #3 sets the outputs of the latches to a TTL "LOW" and Diagnostic #4 sets them to a TTL "HIGH". Use a logic probe, oscilloscope, or voltmeter to verify the logic levels of the latch outputs, and that the levels change when going from Diagnostic #3 to #4.

8-274. DIAGNOSTIC #5: FRONT END SWITCH TEST

8-275. This subroutine tests each of the following 5335A front end data switches:

Channel A and B X10
Channel A and B Slope
Channel A and B Preset
COM A
AUTO TRIG

Refer to *Figure 8-45*, Diagnostic #05 Shaded Block Diagram.

NOTE

The Channel A and B 1 M Ω /50 Ω and AC/DC switches are not tested.

8-276. In this diagnostic, the leftmost eight digits of the display are used to give an active response for each of the tested front end data switches. Begin by pressing all of the tested switches (listed above) to the "IN" position. Key-up Diagnostic #5 and observe the display in *Figure 8-46*.

8-277. When a switch is active ("IN" position), the indicated LED should light. When released ("OUT" position) the indicated LED should blank out.

NOTE

This diagnostic is not operational with Option 040.

8-278. DIAGNOSTIC #6: REAR PANEL ARM-SLOPE SWITCH TEST

8-279. This is a subroutine that tests the A6 rear panel arming switches in their different modes of operation; also tested is the External Time Base Input. In this diagnostic, the third through eighth (from the left) digits are used to give an active response for various switches and inputs. Key up Diagnostic #6 and observe the display in *Figure 8-47*.

8-280. Placing the EXTERNAL ARM switches to the \mathcal{F} or \mathcal{E} positions should light up the indicated LED. The OFF position should blank out both digits. During this test, if any of the software-read front panel switches are pressed, the segments and decimal point of the third digit from the left will cycle once (e.g.,

Figure 8-44. Diagnostic #02 Shaded Block Diagram

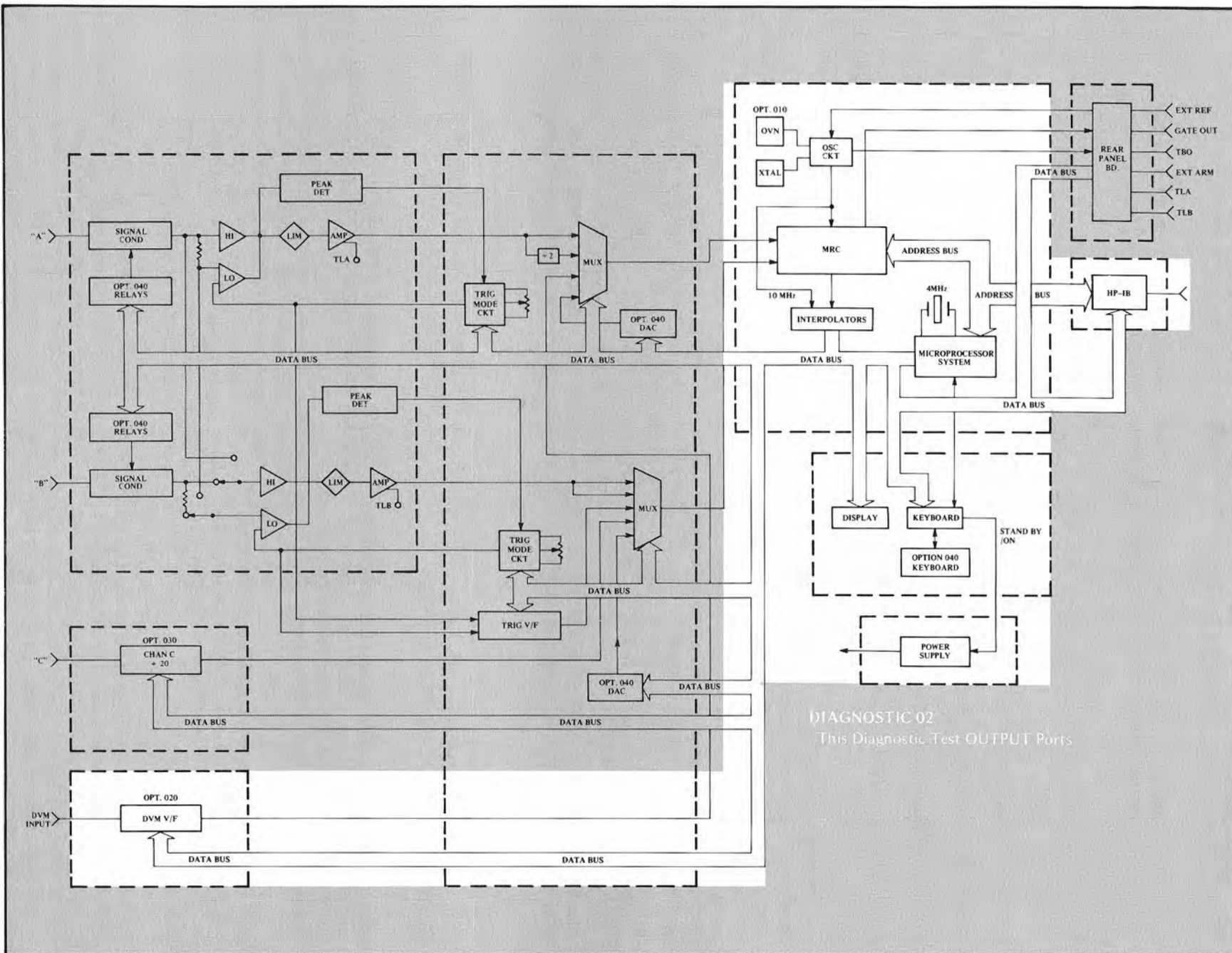

DIAGNOSTIC #02
This Diagnostic Test OUTPUT Ports

Figure 8-45. Diagnostic #05 Shaded Block Diagram

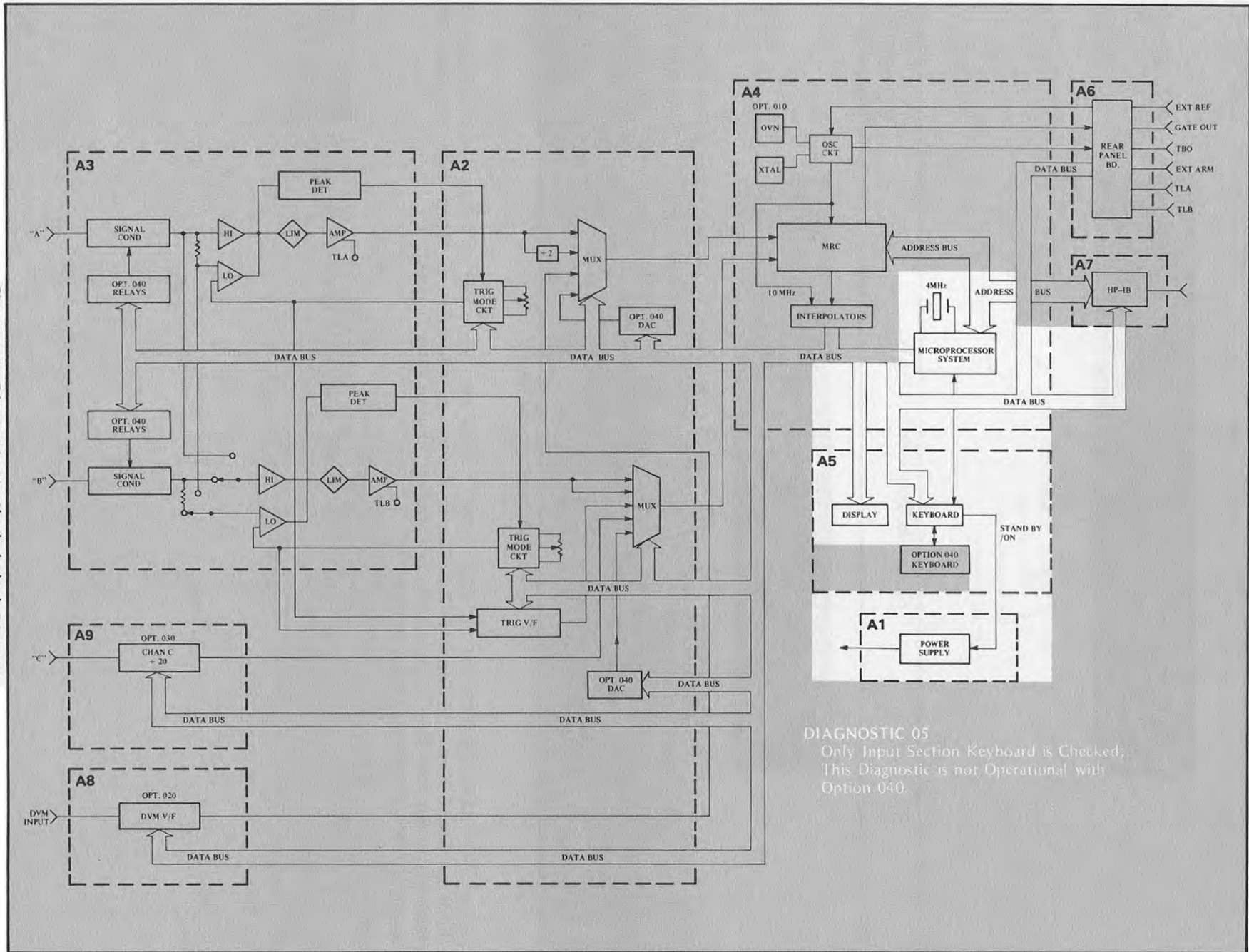

DIAGNOSTIC 05
 Only Input Section Keyboard is Checked;
 This Diagnostic is not Operational with
 Option 040.

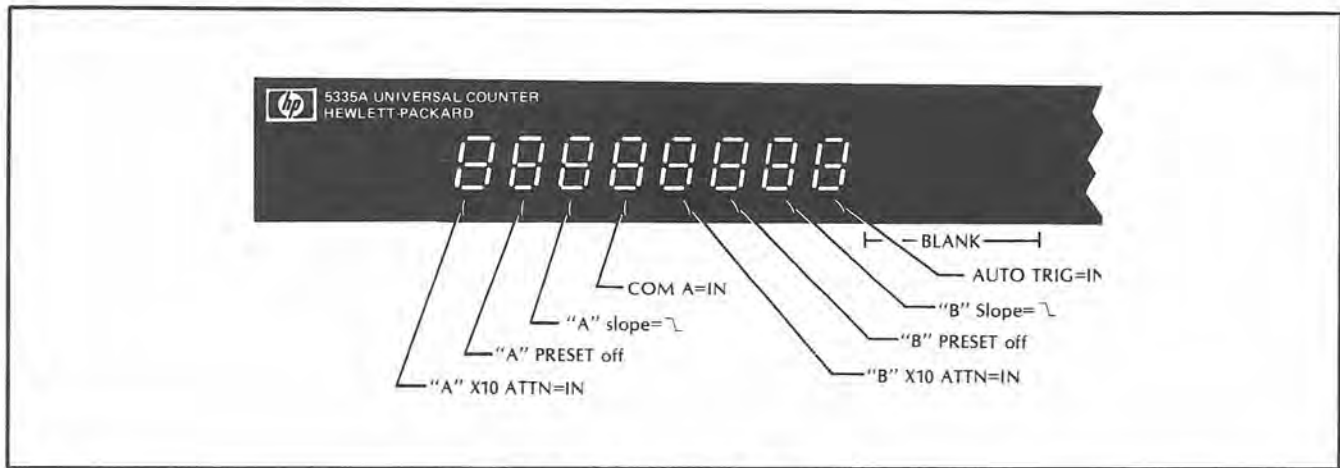

Figure 8-46. Diagnostic #05 Display

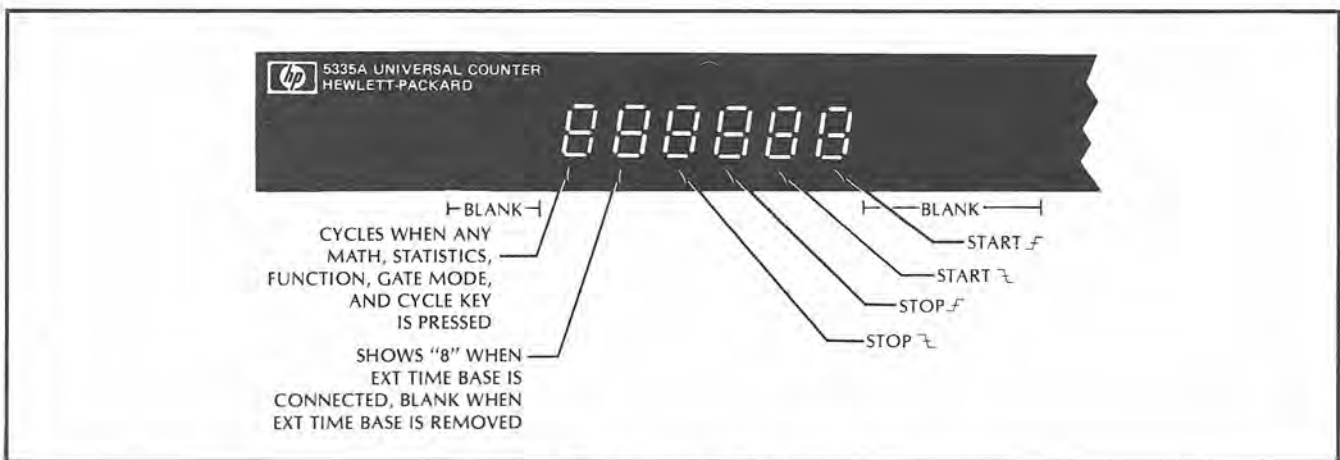
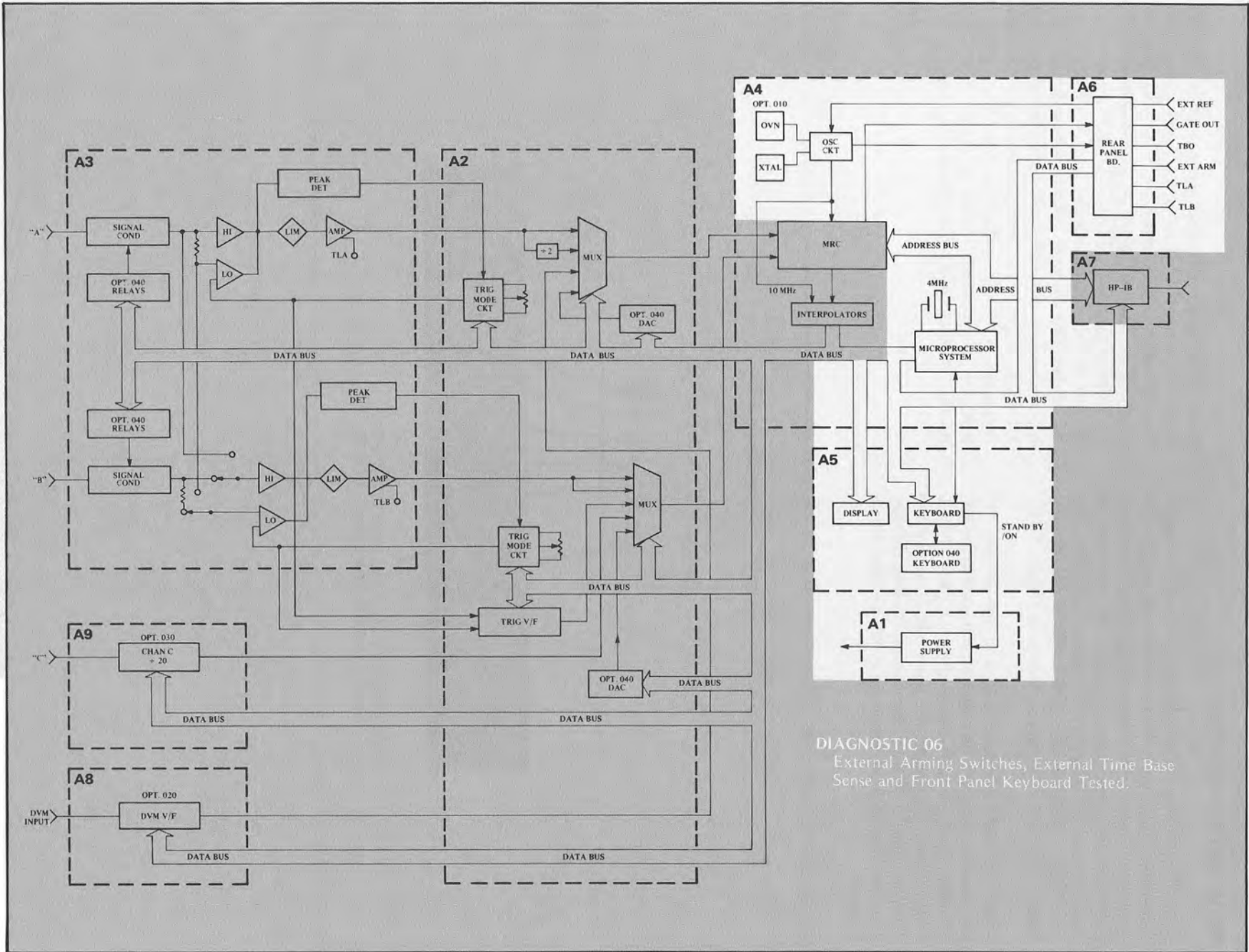

Figure 8-47. Diagnostic #06 Display

keys from the MATH, STATISTICS, FUNCTION, GATE MODE or CYCLE blocks). If the Time Base Out is connected to the Time Base In while in this test, the fourth digit from the left will display an eight "8". To

exit this subroutine, the 5335A power should be turned off. Refer to Figure 8-48, Diagnostic #06 Shaded Block Diagram.

Figure 8-48. Diagnostic #06 Shaded Block Diagram



DIAGNOSTIC 06
External Arming Switches, External Time Base Sense and Front Panel Keyboard Tested.

8-281. DIAGNOSTIC #7: HP-IB SWITCH STATUS

8-282. This subroutine is designed to test the *Status* of the HP-IB address switches. In this diagnostic, the second through eighth (from the left) digits are used to give an active response for each of the seven HP-IB switches. Key up Diagnostic #7 and observe the display. The individual LEDs will indicate the current status of the HP-IB switch as shown in *Figure 8-49*.

8-283. If the individual switch is set in the "1" position, the digit will be blanked; if it is set in the "0" position, the digit will be turned on, i.e., an "8" will be displayed. Changing the positions of any of the switches should change the corresponding display. Refer to *Figure 8-50*, Diagnostic #07 Shaded Block Diagram.

8-284. DIAGNOSTIC #9: MRC SHORT TEST

8-285. This diagnostic does a check of the Multiple Register Counter (MRC) and the Time Base, without testing the overflow network. The MRC status is checked at various points of a measurement. The contents of the MRC "E" and "T" registers are tested to see if they match under check measurement tolerances. The absolute value of the time base count is also checked. The 5335A will display messages "FAIL 4.1 → 4.6" if any of the tests fail. See *Table 4-2* for Fail Messages. A "PASS" message will be displayed if all tests are within limits. Refer to *Figure 8-51*, Diagnostics #09 and #10 Shaded Block Diagram.

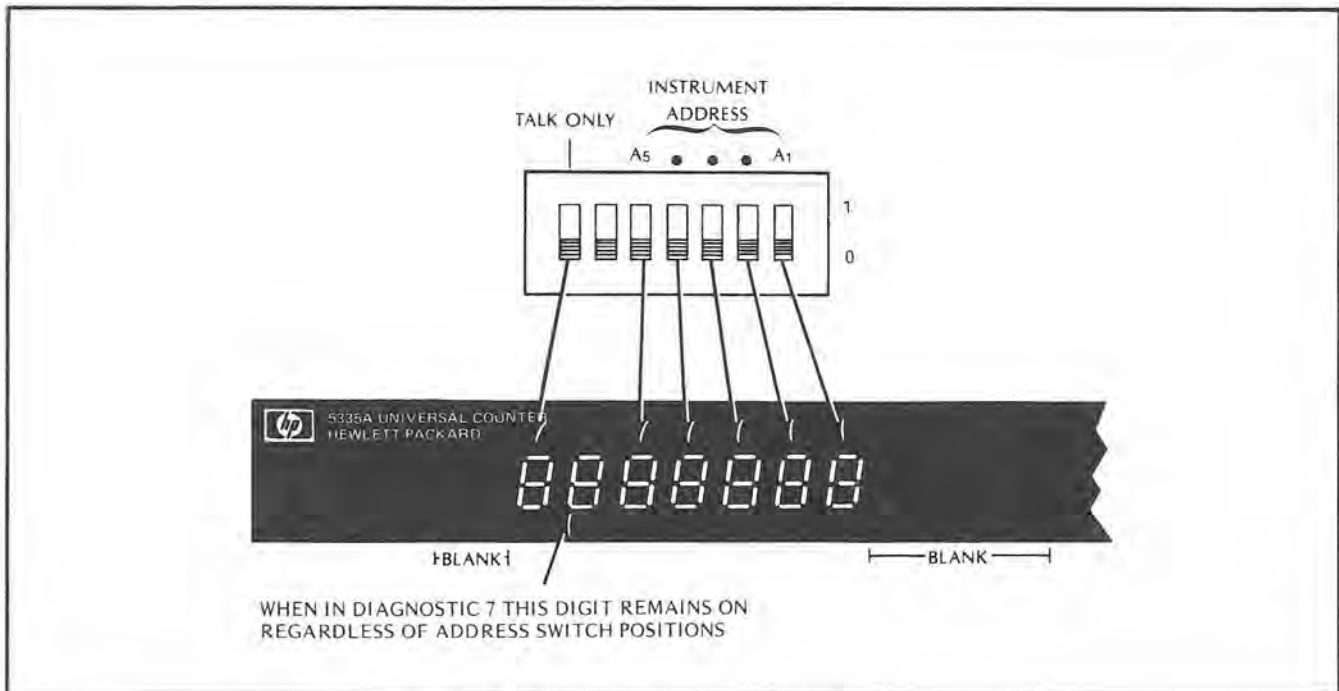

Figure 8-49. Diagnostic #07 Display

Figure 8-50. Diagnostics #07 and #16 Shaded Block Diagram

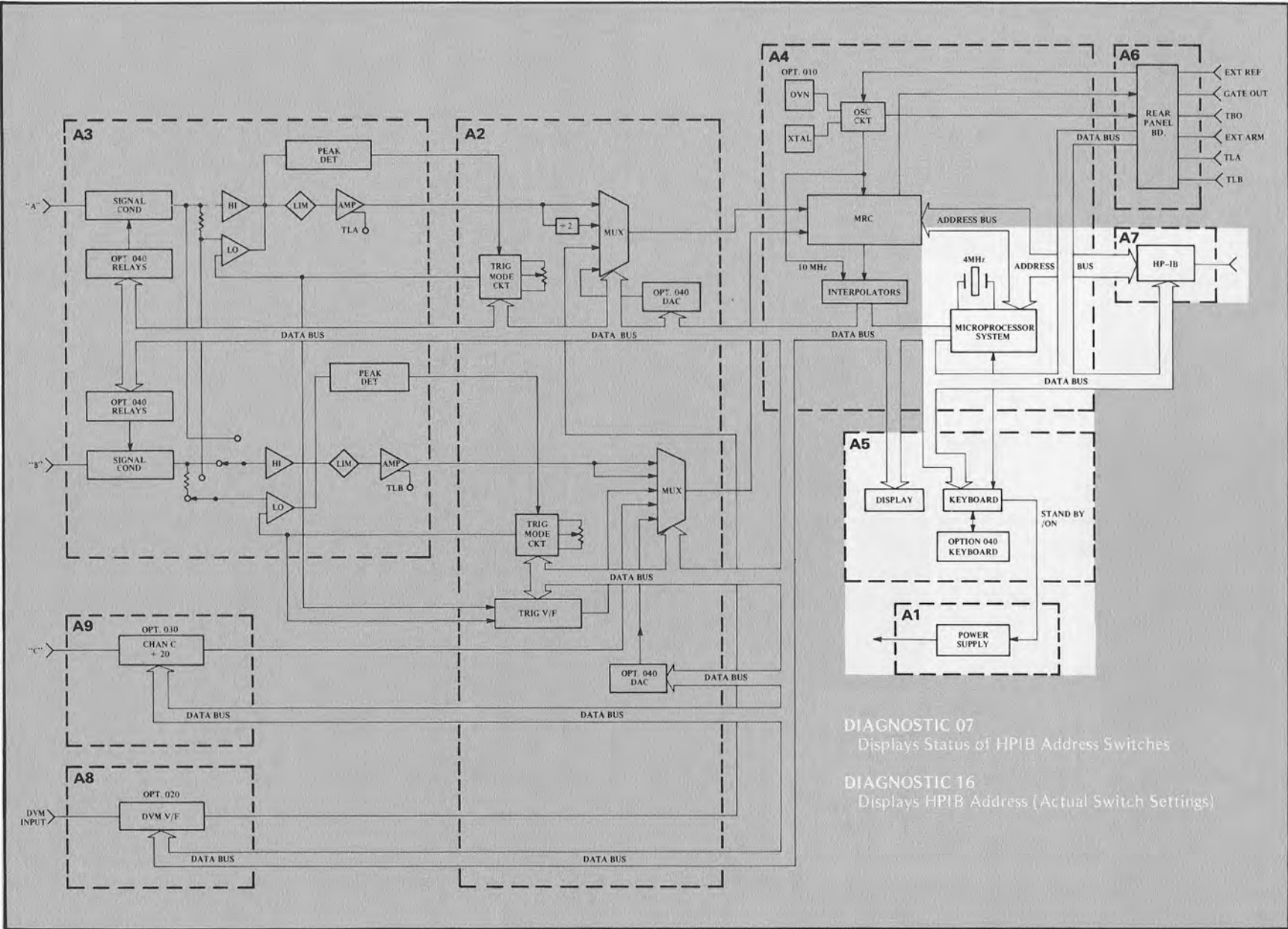
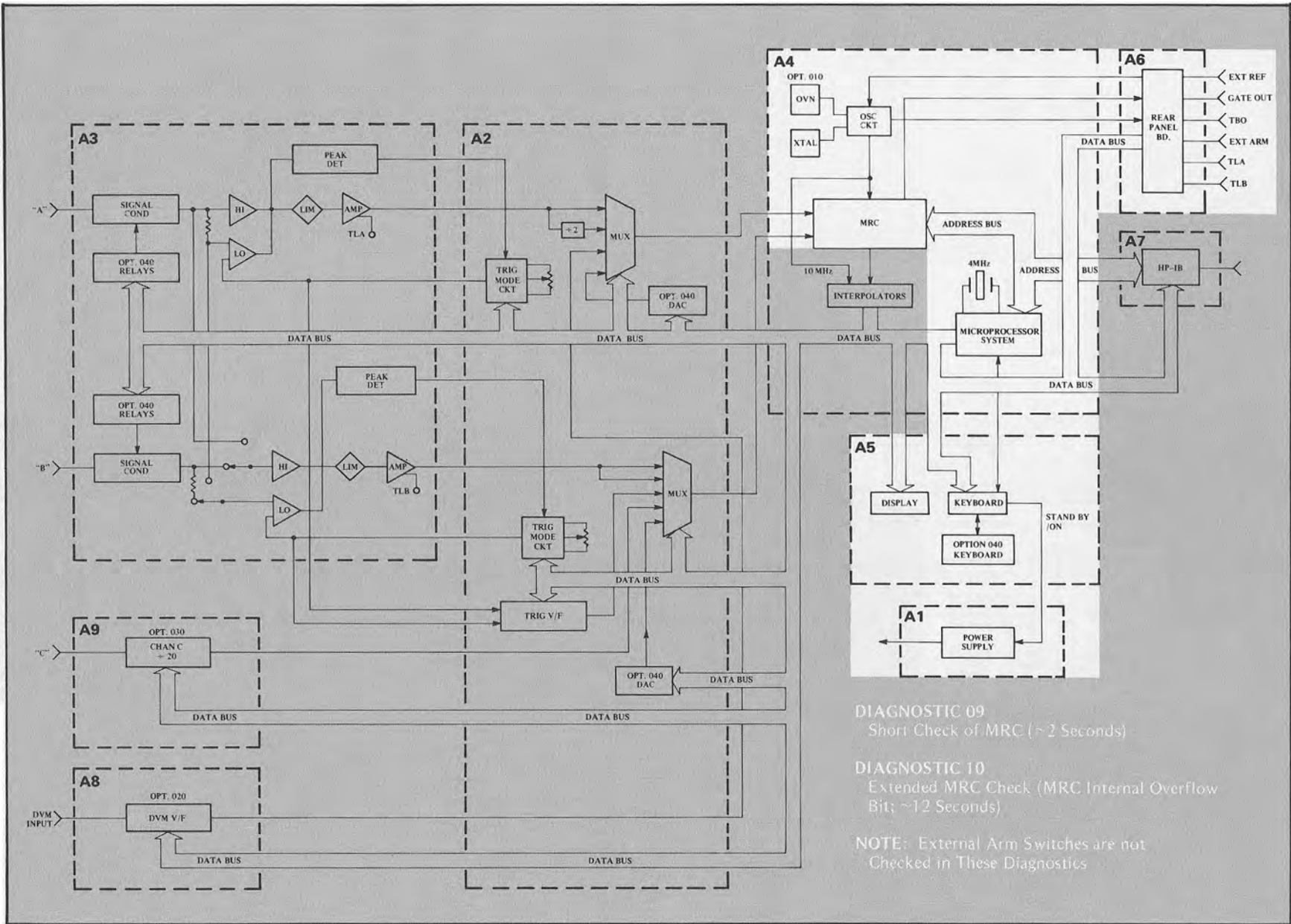

Figure 8-51. Diagnostics #09 and #10 Shaded Block Diagram



**8-286. DIAGNOSTIC #10:
MRC EXTENDED TEST**

8-287. This diagnostic does a basic check of time base and the MRC as in Diagnostic #9. Additionally, an extended test of the MRC is done by checking the slower decades and the overflow network. Failure message 4.7 – 4.9 may be displayed during this subroutine. This diagnostic routine takes about 10 seconds. If the MRC tests are within limits, a “PASS” message will be displayed.

**8-288. DIAGNOSTICS #11, #12 AND #13:
INTERPOLATOR COUNTERS TEST**

8-289. These diagnostic subroutines are designed to aid in the troubleshooting of the START and STOP interpolators: A4U5, U8, U4, U13, U14, U9, the Current Sources (U31A and B) plus related circuitry. Short and long calibrating pulses are used to set up the interpolators for troubleshooting. Diagnostic #11 is set up with a long calibrating pulse and it is cycled as fast as possible for better oscilloscope viewing. While in this subroutine, the 5335A will display: “DIAG 11”.

8-290. Diagnostic #12 is set up with a short calibrating pulse. The contents of the interpolator counter will be displayed; two 3-digit numbers will be representing the START count (left number) and the STOP count (right number). Both numbers should be similar (± 10 counts).

8-291. Diagnostic #13 is similar to Diagnostic #11, but when in this subroutine the contents of the interpolator counters are displayed. The numbers displayed should be approximately 26 to 86 counts less than the numbers displayed in Diagnostic #12.

8-292. See paragraph 8-415 for typical waveforms; and refer to *Figure 8-52*, Diagnostics #11, #12, and #13 Shaded Block Diagram.

**8-293. DIAGNOSTIC #14:
FRONT END CHECK**

8-294. This diagnostic subroutine is designed to check out the 5335A front end circuitry with a 10 MHz signal

applied to INPUT A. Connect the rear panel TBO, (or an external 10 MHz sine wave at $\approx 1V$ rms) to INPUT A. When Diagnostic #14 is keyed up, the following sequence of tests will be performed automatically:

- a. Presence of the signal in Channel A (if no signal, ERROR 7.0 is displayed)
- b. Accuracy of the signal in Channel A (FAIL 7.1 if wrong frequency)
- c. Check Channel B for Cross Talk (FAIL 7.2 if 10 MHz is detected in Channel B; SEP/COM A in SEP)
- d. Presence of signal in Channel B (FAIL 7.3 if no trigger through COM A)
- e. Accuracy of signal in Channel B (FAIL 7.4 if wrong frequency)
- f. Check Channel A prescaler (A2U11 and U7) (FAIL 7.5 if malfunctioning)
- g. A “FE PASS” message will be displayed if all of the above tests are successfully completed. Refer to *Figure 8-53*, Diagnostic #14 Shaded Block Diagram.

**8-295. DIAGNOSTIC #15:
FRONT PANEL DISPLAY TEST**

8-296. This diagnostic subroutine turns on all of the 5335A front panel display LED's, including the annunciators and the momentary switches. The Channel A and B trigger lights and the standby (STBY) LED are not tested. When Diagnostic #15 is keyed up, verify that all the indicated LEDs light up. Refer to *Figure 8-54*, Diagnostics #15 and #17 Shaded Block Diagram.

NOTE

The display may flicker a bit. This is because the circuitry is being continuously written to by the microprocessor.

Figure 8-52. Diagnostics #11, #12, and #13 Shaded Block Diagram

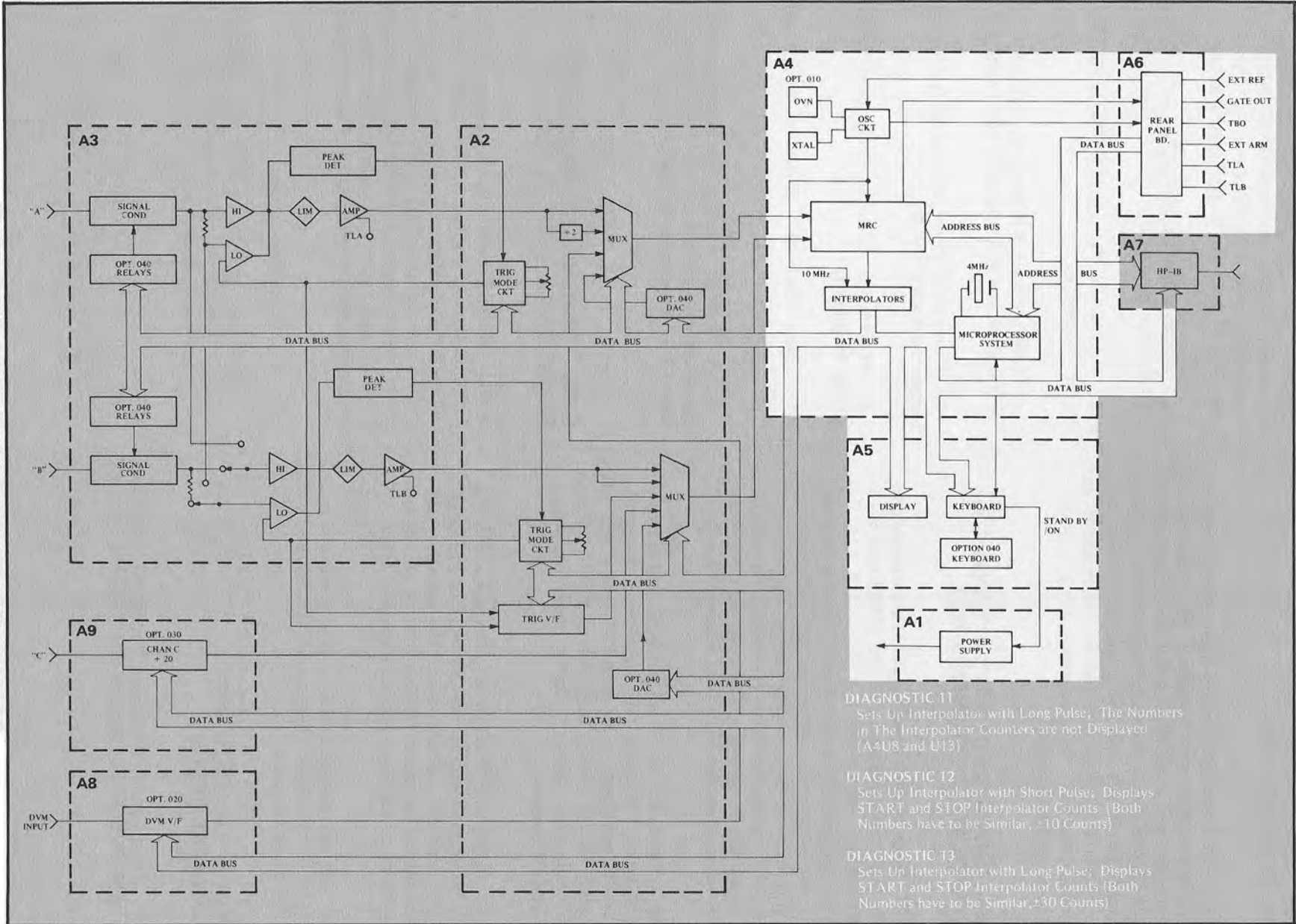
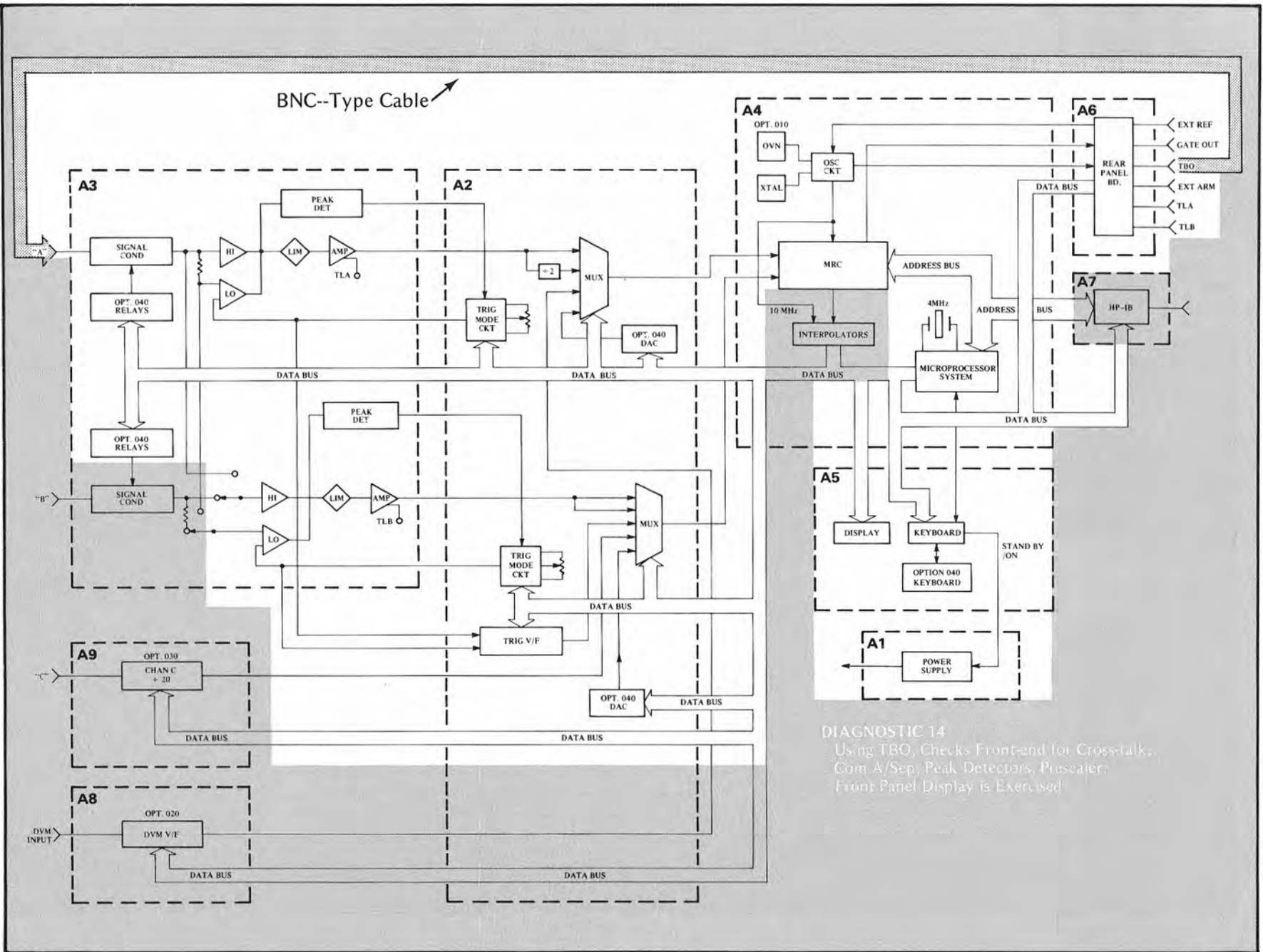
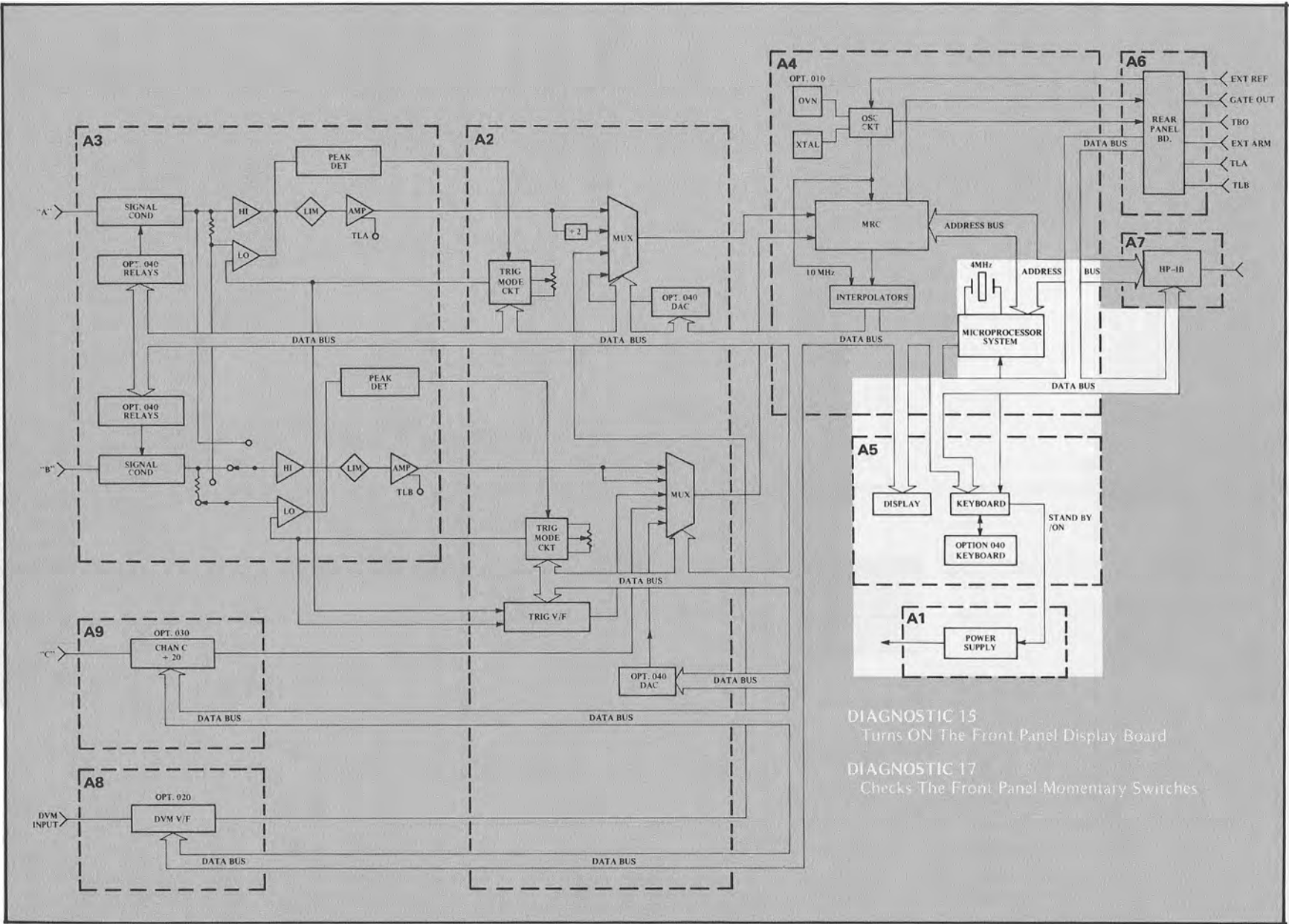

Figure 8-53. Diagnostic #14 Shaded Block Diagram



DIAGNOSTIC 14
 Using TBO, Checks Front-end for Cross-talk,
 Com A/Sep, Peak Detectors, Pluscaler,
 Front Panel Display is Exercised

Figure 8-54. Diagnostics #15 and #17 Shaded Block Diagram



**8-297. DIAGNOSTIC #16:
HP-IB ADDRESS SWITCH**

8-298. This diagnostic will check the status of the HP-IB address switches, similar to Diagnostic #7. This routine, however, decodes this information and displays a decimal HP-IB Bus address (i.e., HP-IB Addr 28). While in this subroutine, any change in the setting of the switches will be immediately decoded and the corresponding HP-IB Bus address will be displayed. Refer to *Figure 8-55* for example display.

**8-299. DIAGNOSTIC #17:
KEYBOARD CHECK**

8-300. This diagnostic subroutine is designed to verify the ability of the microprocessor to identify an individual software-read front panel momentary switch when it is pressed. When Diagnostic #17 is keyed up, a number should be displayed when any switch is pressed corresponding to *Figure 8-56*. The selected key's LED will remain ON while the number is being displayed. A "+ 0" will be displayed in the exponent section of the display during the test.

NOTE

To exit this diagnostic, the 5335A Power Switch must be cycled to STBY and back ON.

**8-301. DIAGNOSTIC #18 AND #19:
DAC ADJUSTMENT (OPTION 040)**

8-302. These diagnostic subroutines (#18 and #19) are designed to set up the trigger level DAC's (A11U23 and A11U21), for adjustment. These DAC's are on A11 Assembly of the 5335A Option 040 programmable front end. These two diagnostics are also used to troubleshoot A11 (Option 040). Refer to *Figure 8-57*, Diagnostics #18 and #19 Shaded Block Diagram.

8-303. When Diagnostic #18 is keyed up, this subroutine programs the Channel A and B trigger level DAC's to "0" volts.

8-304. When Diagnostic #19 is keyed up, this subroutine programs the Channel A and B trigger level DAC's for "-5.12" volts.



Figure 8-55. Diagnostic #16 Display Example

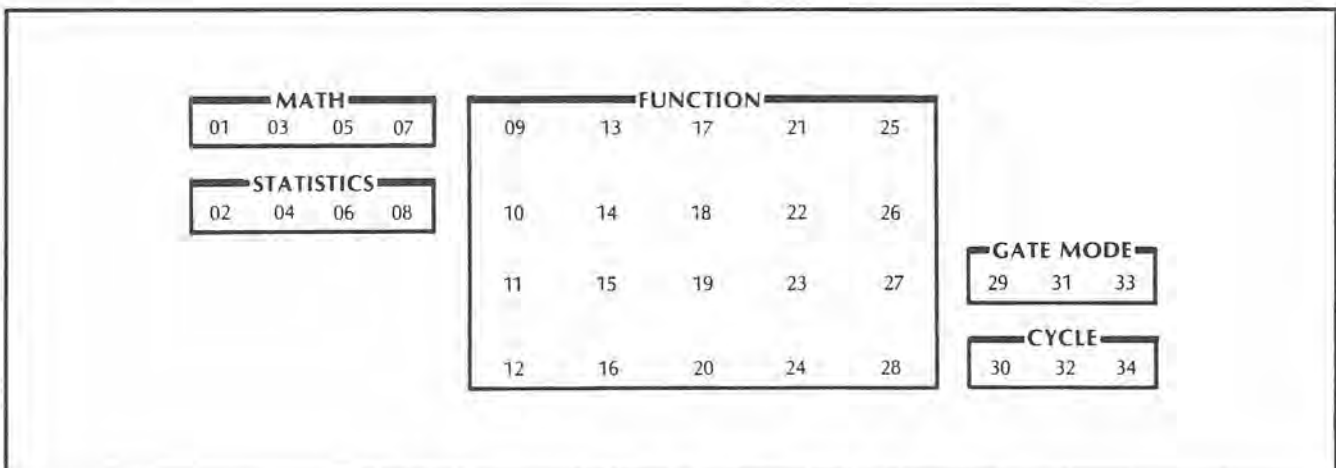
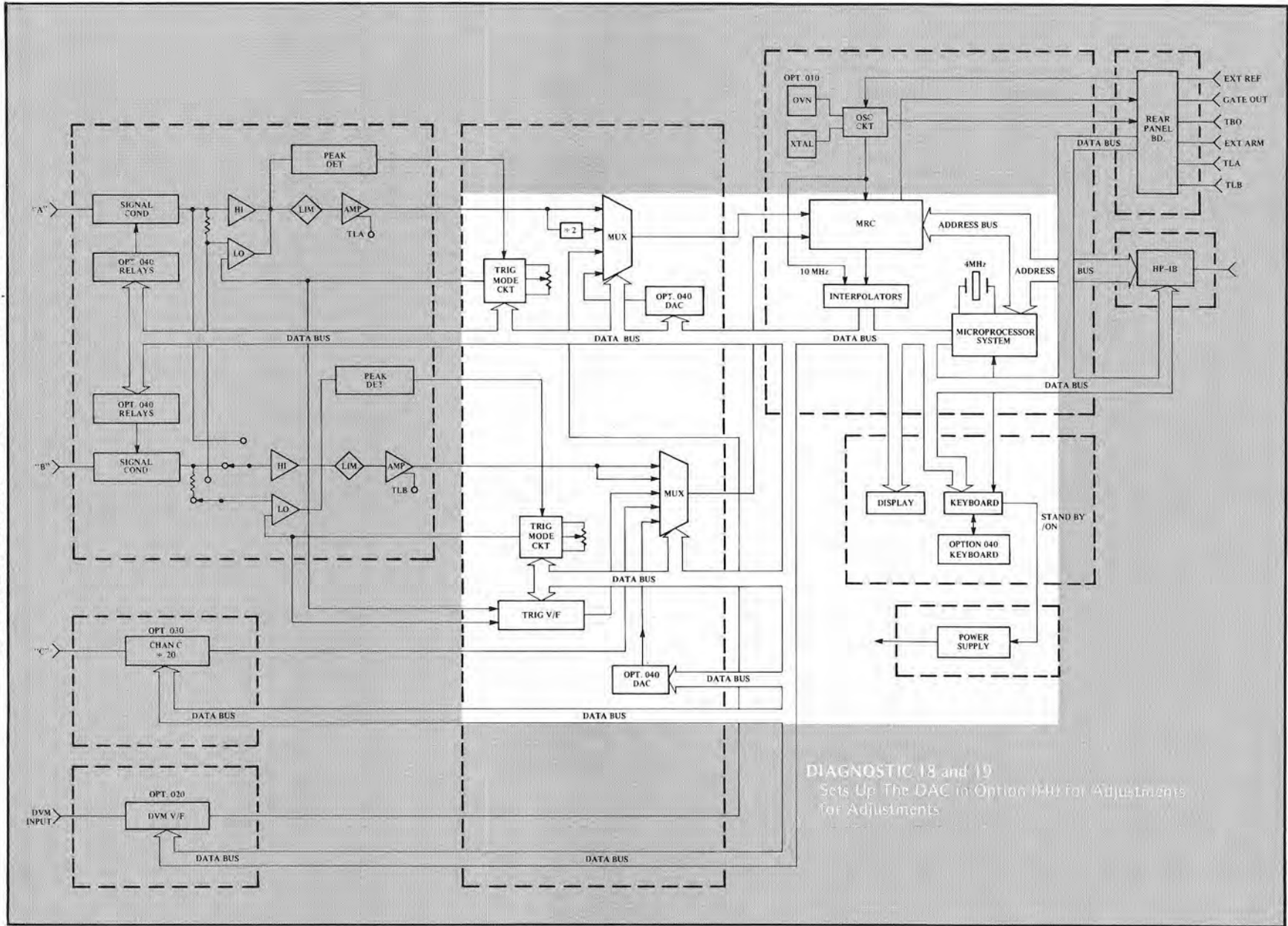

Figure 8-56. Diagnostic #17 Keyboard Check Key Assignments

Figure 8-57. Diagnostics #18 and #19 Shaded Block Diagram



**8-305. DIAGNOSTIC #20, #21 AND #22:
DVM REFERENCE TEST (OPTION 020)**

8-306. These diagnostic subroutines are designed to set up the DVM option to measure and display the voltage and frequency of the -5V, GND and +5V references. These subroutines verify all the A8 DVM circuitry, with the exception of A8U11. Refer to *Figure 8-58*, Diagnostics #20 through #25.

8-307. When Diagnostic #20 is keyed up, with the "RANGE HOLD" OFF, the 5335A will display the voltage of the -5V reference. With "RANGE HOLD" ON, the corresponding -5V reference frequency will be displayed. (This is true for all diagnostics that read in volts.) In the same manner, Diagnostics #21 and #22 measure and display the voltage and frequency of the GND (0.00V) and +5V references. Refer to the following table for expected results:

| | DIAGNOSTIC | | |
|----------------|------------|-----------|------------|
| | 20 | 21 | 22 |
| RANGE HOLD OFF | -5.00000V | 0.00000V | +5.00000V |
| RANGE HOLD ON | 900 Hz-V | 6.1 kHz-V | 11.3 kHz-V |

**8-308. DIAGNOSTIC #23, #24 AND #25:
DVM RANGE TEST (OPTION 020)**

8-309. These diagnostic subroutines force the DVM option into its LOW, MED, and HIGH range, respectively. By inputting a known dc voltage to the DVM input, the input amplifier A8U11, the FET's and transistor, which select the different ranges, can be tested. The autorange feature of the DVM is disabled in these tests.

**8-310. DIAGNOSTIC #26, #27 AND #28:
TRIGGER LEVEL DVM REFERENCE TEST**

8-311. Refer to *Figure 8-59*, Diagnostics #26 through #33 Shaded Block Diagram. These diagnostic subroutines set up the trigger level DVM in the A2 amplifier support assembly so that the -5 volt, GND, (0.0 volt) and +5 volt reference voltages and frequencies can be measured and displayed. These subroutines operate the same as Diagnostics #20, #21 and #22. Diagnostic #26 programs the A2U4 multiplexer to read the -5V reference; Diagnostics #27 and #28 program the multiplexer to read the ground and +5 references respectively. A2U14, U15, U12, U4, U8, U9, and U7 are exercised with these subroutines. The following table lists the results:

| | DIAGNOSTIC | | |
|----------------|------------|-----------|-----------|
| | 26 | 27 | 28 |
| RANGE HOLD OFF | -5.00000V | GND REF | +5.00000V |
| RANGE HOLD ON | 190 Hz-V | 1.9 kHz-V | 3.7 kHz-V |

**8-312. DIAGNOSTIC #29 AND #30:
TRIGGER LEVELS A AND B TEST**

8-313. These diagnostic subroutines are similar to Diagnostics #26 through #28, except that the actual trigger level voltage for both Channels A and B can be varied over the entire range during this exercise. Again, the corresponding frequency for a given voltage can be displayed by activating "RANGE HOLD".

**8-314. DIAGNOSTIC #31, #32, #33:
A4 DVM POWER SUPPLIES TEST**

8-315. These three diagnostics are similar to Diagnostics #26 through #28, except that the voltage and frequency of the three power supplies are measured and displayed. Diagnostic #31 measures the +5 volt supply, #32 measures the +3 volt supply, and #33 measures the -5.2 volt supply. Pressing "RANGE HOLD" will display the corresponding frequencies. The following table lists the results:

| | DIAGNOSTICS | | |
|----------------|-------------|------------|-----------|
| | 31 | 32 | 33 |
| RANGE HOLD OFF | +5.00000V | +3.00000V | -5.20000V |
| RANGE HOLD ON | 3.75 kHz-V | 3.05 kHz-V | 100 Hz-V |

**8-316. DIAGNOSTIC #34: INCREMENTAL
TESTING OF THE DAC'S (OPTION 040)**

8-317. This diagnostic subroutine programs the DAC's in the Option 040 to step through their voltage range (from -5.11V to +5.11V) in increments of 10 mV. This subroutine performs a "functional" test on the DAC, verifying its proper operation. A visual check on the functioning of the DAC can be obtained by connecting Trigger Level A (or B) from the 5335A rear panel to an oscilloscope. The level will vary from -5.11 volts to +5.11 volts continuously. This subroutine exercises the data latches A11U16, 17 and 24, the DAC's A11U21 and U23, and the multiplexer A11U5, plus associated circuitry. When this diagnostic is accessed the 5335A will display: "DIAG 34".

Figure 8-58. Diagnostics #20 through #25 Shaded Block Diagram

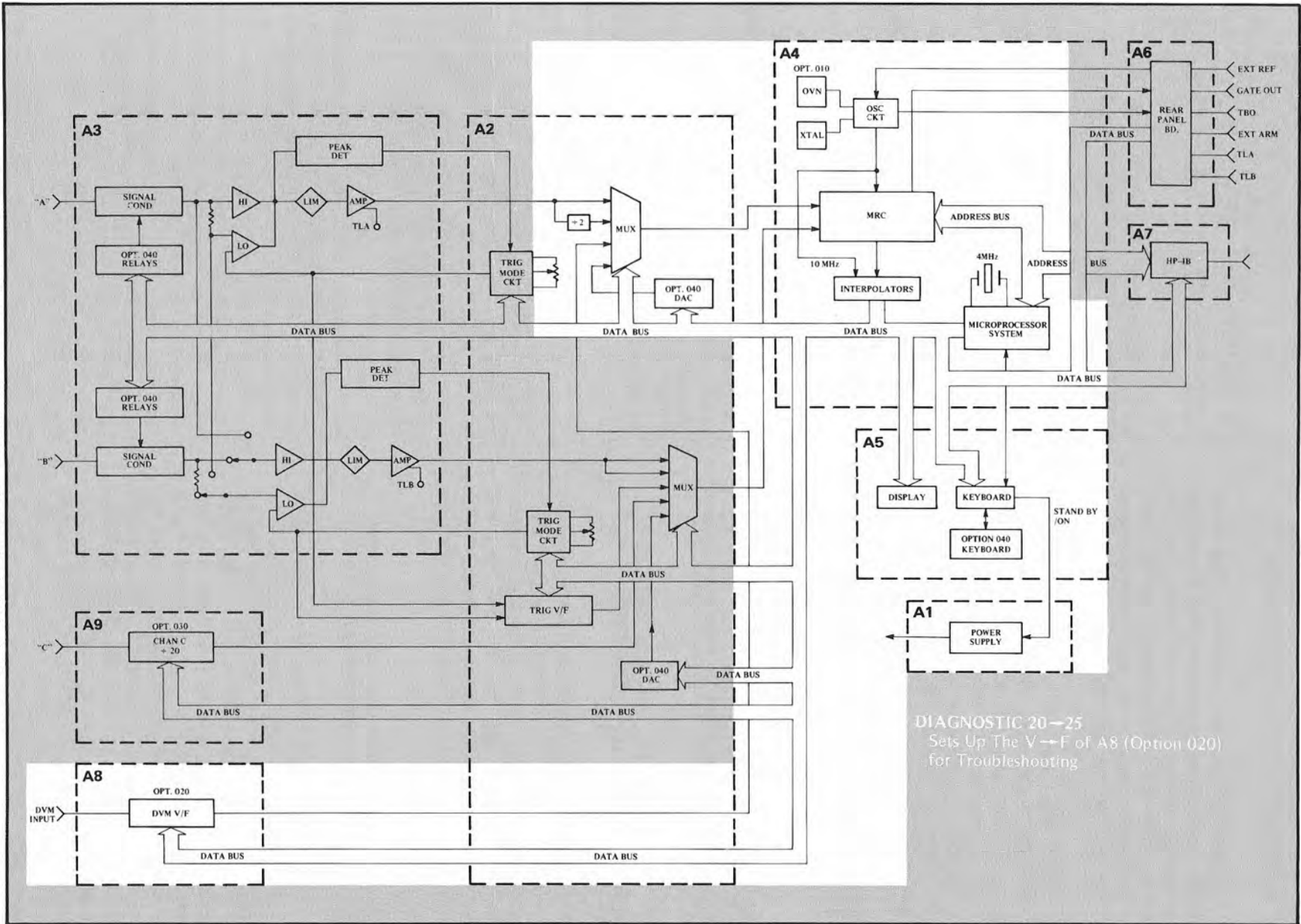
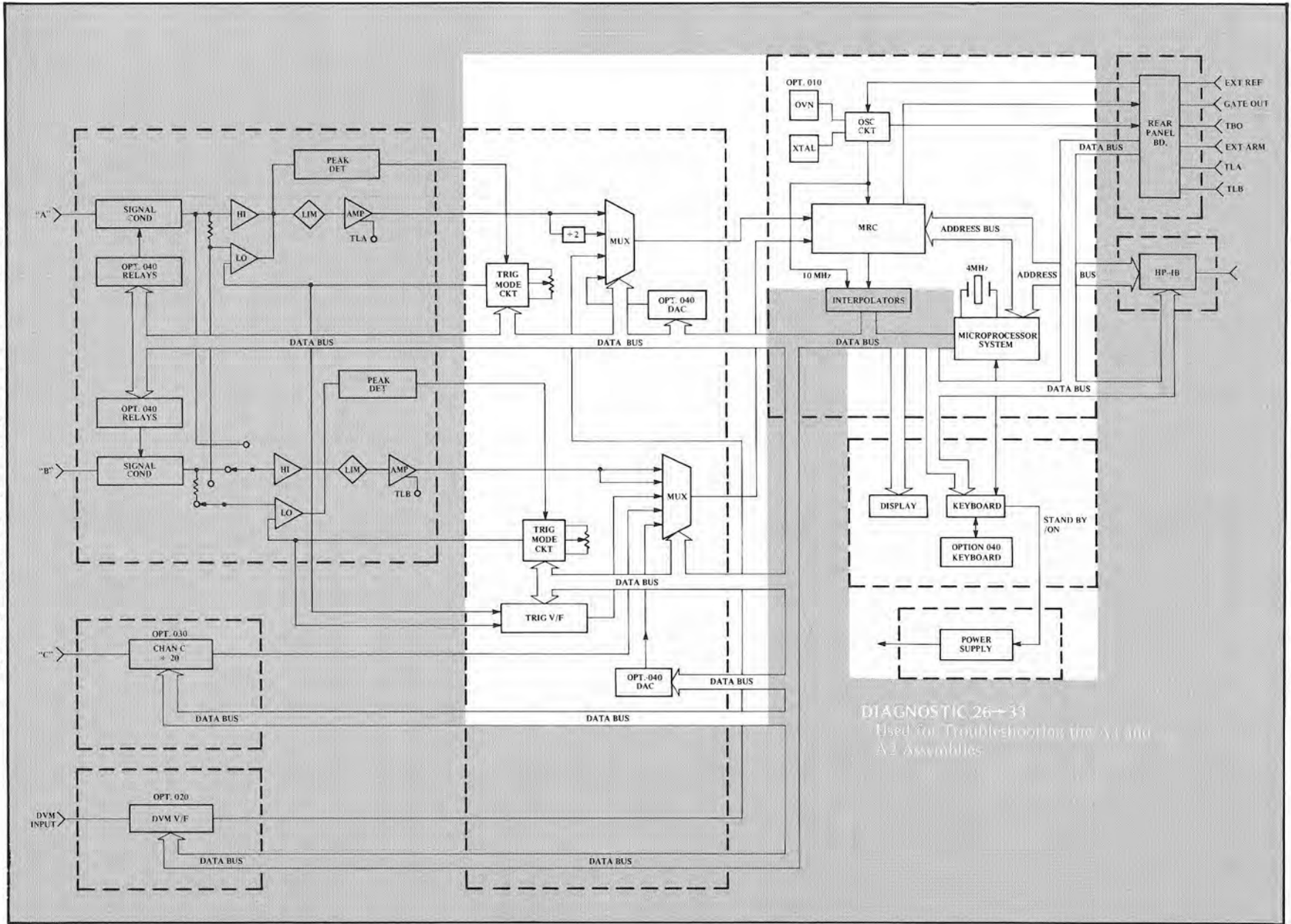

Figure 8-59. Diagnostics #26 through #33 Shaded Block Diagram



8-318. OVERALL TROUBLESHOOTING

8-319. The troubleshooting of the 5335A is keyed with the power-up self-test. The service technician should follow the flowchart procedure to isolate faulty assembly area. Once the problem source is identified, the technician can proceed to the appropriate assembly troubleshooting paragraphs and assembly schematic diagram. However, a complete list of all failure modes is impossible, and this text and schematic information can be expanded by the technician or user.

8-320. For any observed failure mode, it is recommended that the power supplies be checked first. The 5335A power supply contains seven dc supplies: +25 volts, +15.7 volts, -15 volts, +15 volts, +10 volts, +5 volts, +3 volts, and -5.2 volts. These supplies are generated in the A1 assembly; verify that they are within tolerance per *Table 8-7*. Next the 4 MHz microprocessor oscillator should be checked, as well as the 10 MHz timebase oscillator, per paragraph 8-423.

8-321. Once the 5335A power supplies and the microprocessor oscillator are verified to be working OK, the very next step is to verify the proper operation of the 5335A **KERNEL**.

CAUTION

Before switching on the instrument, ensure the following:

1. The transformer primary is matched to the available line voltage.
2. The correct fuse is installed.
3. All safety precautions have been observed.

For details see Power Requirements, Line Voltage Selection, Power Cables, and associated warnings and cautions in Section II of this manual.

8-322. POWER-UP/SELF-CHECK

8-323. First it is necessary to verify the proper operation of the **KERNEL**. The **KERNEL** is the heart of the system, the minimum hardware that must be functioning properly to operate the system. The **KERNEL** of the 5335A Universal Counter is the microprocessor (A4U28), the ROMS (A4U22 & A4U23), the RAMS (A4U25 & A4U26), the bidirectional buffers (A4U16 & A4U24), and the buffer (A4U27).

8-324. When the counter is turned on an automatic internal check is made of the **KERNEL**, the MRC (A4U6), the Start and Stop Interpolators, the A2 Voltage-to-Frequency converter, the input circuitry, the front panel keyboard and display, and the interconnecting data buses. After the power-up sequence, the counter will initialize itself. All Math and Statistics will be OFF, the function will be **FREQ A**, and the Gate and Cycle Modes will be in **NORM**. All of the input controls will be set according to their switch positions.

8-325. Any failures during the power-up cycle will disable the counter and produce one of the following:

- a. A blank display.
- b. A hieroglyphic is displayed.
- c. Display shows a missing segment or digit.
- d. Numbered **ERROR** or **FAIL** message is displayed.

8-326. Refer to *Figure 8-60*, Troubleshooting Flowchart, for further information concerning display types and possible failure messages.

8-327. Proceed with the **POWER-UP/SELF-CHECK** as follows:

- a. **PRESET:** 5335A Power Switch to **STBY (OUT)**.
- b. **VERIFY:** Red Standby Lamp is **ON**.
- c. **SET:** 5335A Power Switch to **ON (IN)**.
- d. **VERIFY:**
 1. Red Standby Lamp is **OFF**.
 2. All display and annunciator lamps turn on for about one second (excluding standby and trigger lamps).
 3. Then the display shows the **HP-IB Address** for about one second.
- e. Successful completion of the **POWER-UP SELF-CHECK** is denoted by the following:
 1. **NO FAIL** or **ERROR** messages Displayed.
 2. Display shows "0."
 3. **Hz lamp** is **ON**.
 4. **FREQ A lamp** is **ON**.
 5. All other lamps are off (except trigger).
 6. **Fan** is **ON**.

NOTE

If the 5335A passes the **POWER-UP SELF-CHECK**, proceed to **SECTION IV** of this manual and perform the **Operation Verification** in paragraph 4-9.

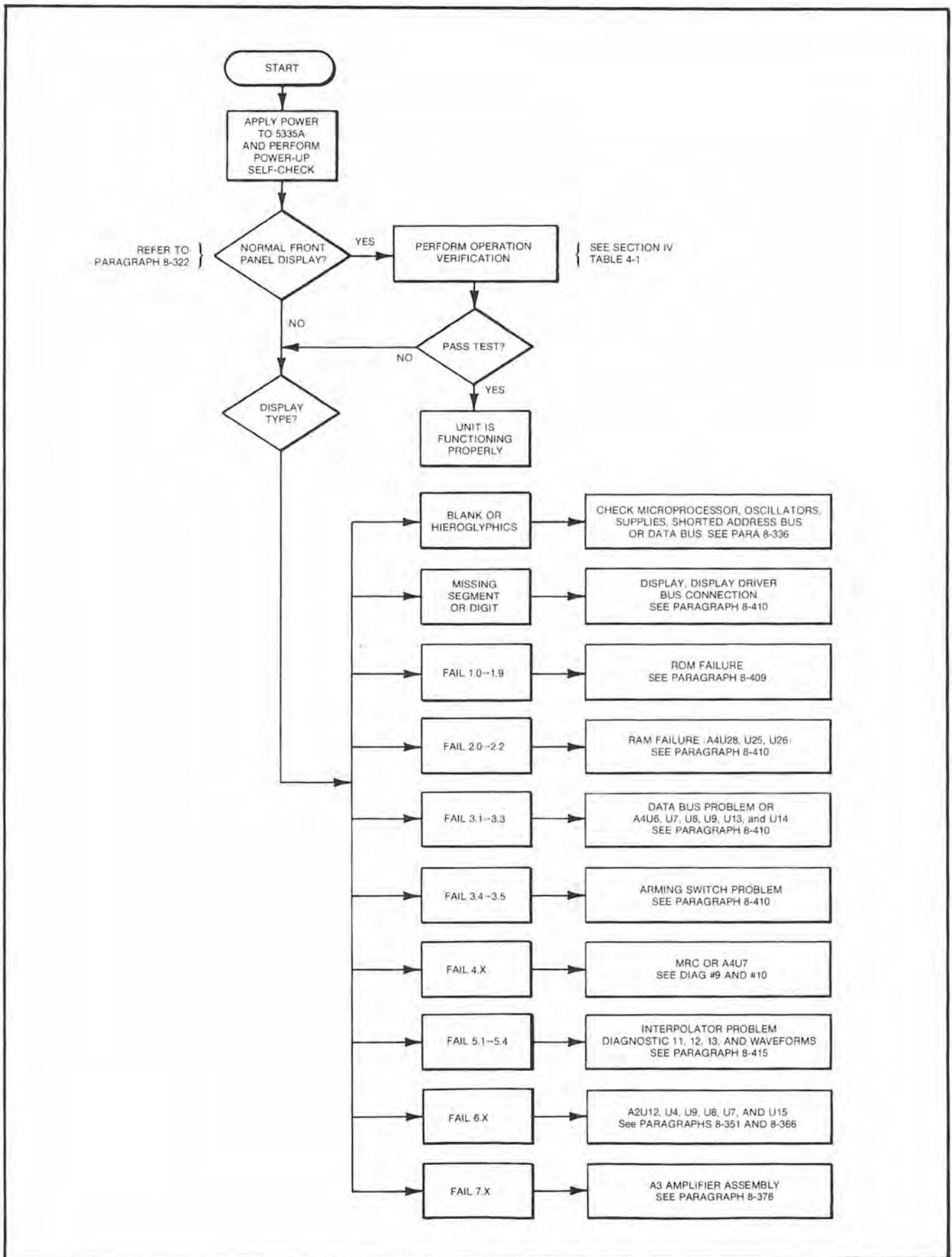

Figure 8-60. Troubleshooting Flowchart

8-328. If a failure occurs at POWER-UP, one of the diagnostics from *Table 8-6* may be used to isolate the failure. (Refer to *Figure 8-60*, Troubleshooting Flowchart, for further information concerning display types and possible failure messages.)

8-329. First establish that the 5335A responds to the keyboard commands by pressing any one of the FUNCTION, MATH, STATISTICS, GATE MODE, or CYCLE keys. If the keyboard responds correctly the key lamp will light, with the exception of the blue MATH keys. If one of the blue MATH keys is pressed the key lamp should flash.

8-330. If the 5335A responds to the keyboard commands proceed to the SUPER CHECK. If the keyboard does not respond as indicated, proceed to paragraph 8-406 for the Signature Analysis of the microprocessor.

8-331. SUPER CHECK (Diagnostic #01)

8-332. The SUPER CHECK is a continuous diagnostic loop which will repeat until manually reset; during this cycle the front end amplifiers are checked for accuracy, cross talk, attenuation and separate/common with the input signal. In addition the 5335A checks the operation of the following:

ROMS
RAMS
DATA BUS
FRONT PANEL DISPLAY
MRC
INTERPOLATORS
TRIGGER LEVEL REFERENCES (GND, +5V, -5V)
CHANNEL A & B TRIGGERING
SEP/COM RELAY
PRESCALER
POWER SUPPLY VOLTAGES (+5V, +3V, -5.2V)

NOTE

For a complete description of the SUPER CHECK refer to paragraph 8-254, and to the Troubleshooting Flowchart, *Figure 8-60*.

8-333. To perform the SUPER CHECK proceed as follows:

a. Connect a 4-foot BNC cable (HP P/N 10503A) from the 5335A rear panel TIME BASE OUT to the front panel INPUT A jack. Set the 5335A 1 M Ω /50 Ω input controls to 50 Ω .

b. Call up Special Function 99 by pressing the following 5335A keys:

1. SCALE verify the SCALE key lamp is flashing.
2. SMOOTH (Display will show "SPECIAL +0".)
3. 9
4. 9
5. ENTER (Display will show "dIAG 01" for about 5 seconds.)

c. VERIFY:

1. All display annunciator lamps turn ON for about 5 seconds.
2. Successful completion of the front end test loop displays the message "FE PASS" for about 15 seconds.
3. Display shows nominal values of 3 Supply Voltages:
5. 000 00 V
3. 000 00 V
-5. 200 00 V
4. The test then repeats itself.

NOTE

If TIME BASE OUT is not connected to INPUT A, ERROR 7.0 will be displayed.

8-334. After successful entry into Special Function 99, any diagnostic can then be called up from the table of diagnostics (Refer to *Table 8-6*). Just press SCALE, (Verify the SCALE key lamp is flashing), the diagnostic number, and ENTER. The 5335A will access the given diagnostic.

8-335. Any failures are identified by a numbered ERROR or FAIL message. (For a description refer to ERROR/FAIL MESSAGES, paragraph 4-7.) If a failure occurs, one of the diagnostics from *Table 8-6* may be used to isolate the failure. (Refer to *Figure 8-60*, Troubleshooting Flowchart, for further information concerning display types and possible failure messages.)

8-336. Procedure for Inaccessible Diagnostics

8-337. If the diagnostics cannot be accessed, proceed as follows: (For example, the front panel display is blank and the 5335A does not respond to the keyboard commands.)

a. Check the Power Supplies. Refer to paragraph 8-338.

b. Check the microprocessor oscillators. Refer to paragraph 8-423. (If the supply voltages are correct, and the oscillators are operating properly, go to step c.)

c. Check the **KERNEL** of the 5335A. Refer to paragraph 8-408. This procedure is done with the microprocessor set in the FREERUN MODE and is not dependent on the front panel display. (If the signatures in *Tables 8-14* and *8-15* are correct, then the Address Bus is functioning properly. Proceed to step d.)

d. Check the ROMS and the Data lines. Refer to paragraph 8-406. If the signatures are correct, the Data Bus is functioning properly. Go to step e.)

e. Check the Keyboard and Display Assembly (A5) for open traces or open circuits, and the cable (W4) that connects the Keyboard and Display Assembly to the Main Logic Assembly (A4) for opens.

8-338. A1 POWER SUPPLY TROUBLESHOOTING

8-339. To verify proper operation of the 5335A, A1 Power Supply Assembly (05335-60001), check the seven dc voltages labeled on the A1 Power Supply board and the ac voltage on A1J1 (4, $\overline{4}$). If you have Option 020 (DVM Assembly 05335-60008), check the ac voltage on A1J1($\overline{4}$) going to the DVM via the A2 Assembly (05335-60002), and on the DVM board (05335-60008).

8-340. There are two adjustable supplies on the A1 Power Supply board, the +3.0V supply and the +15.7V supply. Make sure that all supply voltages are within tolerance. See *Table 8-7*.

Table 8-7. A1 Power Supply Voltage Tests

| VOLTAGE (Vdc) | TOLERANCE (Vdc) | ADJUSTMENT |
|---------------|-----------------|------------|
| +15.70 | ± 0.20 | A1R15 |
| -15.00 | ± 0.75 | NONE |
| +10.00 | ± 0.01 | NONE |
| + 5.00 | ± 0.12 | NONE |
| - 5.20 | ± 0.15 | NONE |
| + 3.00 | ± 0.05 | A1R1 |
| +24.50 | ± 2.50 | NONE |

8-341. If any of the voltages are not present at the supplies, check voltages at the fuse holders and at A1CR8 (pins marked + and - on the PC board and the schematic). Refer to the A1 power supply schematic and the block diagram (*Figure 8-61*) for additional information. If the voltages are present at the fuse

holders, but not at the supplies, suspect the A1K1 relay.

8-342. If any of the power supply voltages are low, isolate the A1 Power Supply assembly by disconnecting the following:

a. The A2 Amplifier Support assembly (05355-60002) from the A1 Power Supply assembly.

b. The A4 Main Logic assembly (05335-60004) from the A1 Power Supply via W2.

NOTE

Connect A1J1(16)→A1J1(1) with a jumper.

c. The A5 Keyboard and Display assembly (05335-60005) from the A4 Main Logic Assembly via W4.

8-343. If the Power Supply voltages come back up to the specified values, reconnect a, b, and c above one at a time, checking the supply voltages on A1 after each assembly is reconnected. This will enable you to determine which assembly is loading down the supply voltages.

8-344. If the power supply voltages do not come back up to the specified values, troubleshoot the supply voltages on A1 as follows:

a. Check the +15 volt supply at A1U6(3); it should be at +15.7 volts ± 0.2 volts. If it is not correct, check U1U6, CR2, C6, C7, and K1.

b. Check the +10 volts reference supply at A1U1(2) level should be at +10.00V ± 0.01 V. This supply is used as a reference for the +5 voltage (A1U3), -5.2 volts (A1U2) and also, as a reference voltage for the trigger level voltmeter, in the A2/A11 assemblies. If voltage is lower or higher than specified, check A1U1, U2, and U3.

c. Check the +5 volt supply at A1TP1 for a voltage of +5V ± 0.12 V. If voltage is not at the specified level, check the Q1 on the back panel (TO-3 package), A1Q3, CR3, CR4, U3, U4, C2, C4, and C8.

d. Verify the operation of the +3 volt supply at A1U4(2); voltage should be 3.0V ± 0.05 V. If the voltage is not correct, check U4 and U3.

e. Check the -5.2V supply at A1J1(3), for a value of -5.2V ± 0.12 V. If voltage not present at specified level, check A1Q1; Q2, U2, CR1, C1.

f. Check the -15V supply at A1U7(3), for a voltage level of -15V ± 0.75 V. If it is not correct, check U7, C10, and CR6.

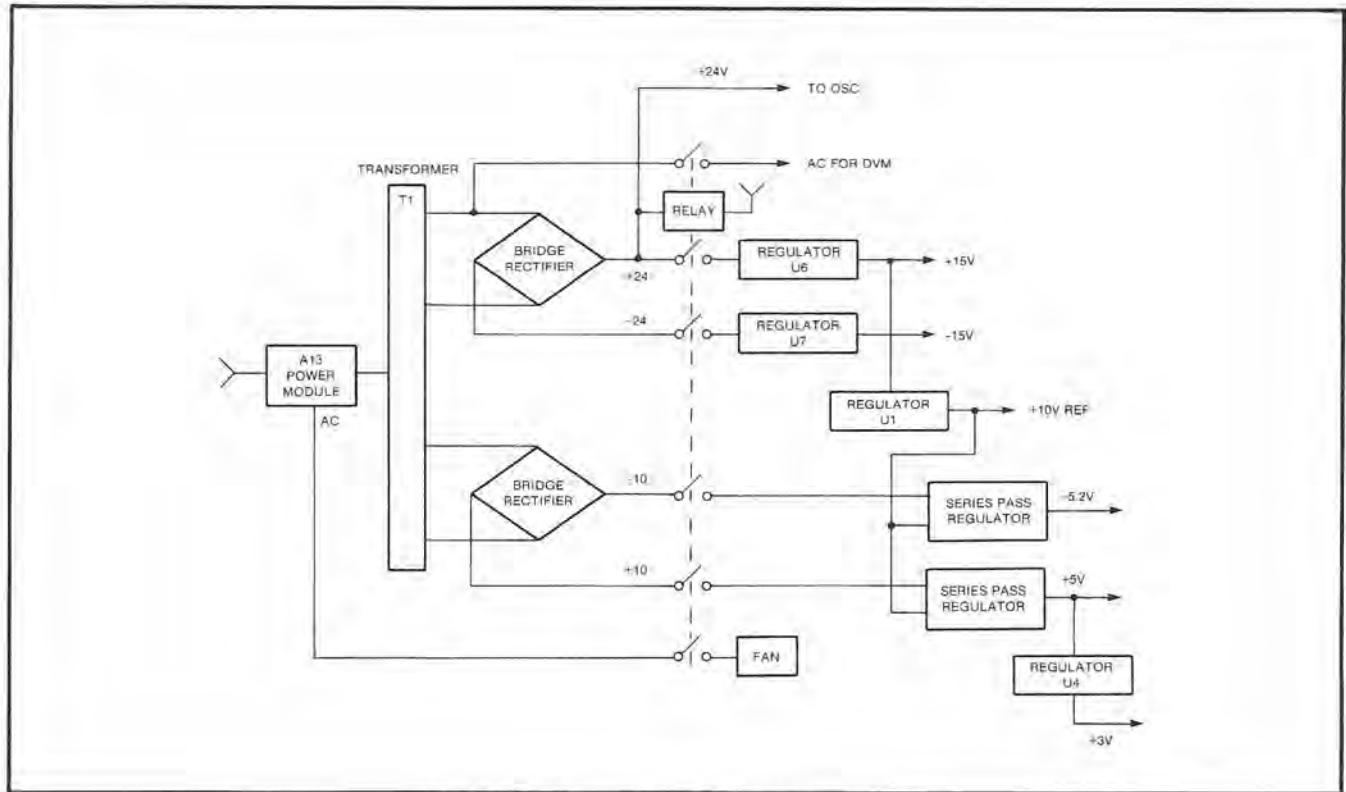

Figure 8-61. Power Supply Block Diagram (A1)

8-345. A2 AMPLIFIER SUPPORT TROUBLESHOOTING

8-346. The A2 Amplifier Support Assembly contains the Channel A and B Trigger Level selector, the Trigger Level Voltmeter, the Signal Selector Multiplexer, and the Front End latch control circuitry. The Trigger Level Selector and the Front End latch control circuits complements the peak detector operation in the A3 Input Buffer assembly.

8-347. Trigger Level Selector Troubleshooting

8-348. Channel A Trigger Level Selector Multiplexer (A2U2) selects among the different input signals (Channel A trigger level pot, the 10%, 50%, and 90% of peak of signal, Ground, and -5.2V), a trigger level that is fed back to the A3 assembly. This multiplexer is controlled by the microprocessor, by way of A2U15 and U12.

8-349. To troubleshoot the Channel A trigger level selector circuitry, first check the logic levels at A2U2 pins 1, 15, and 16 as follows (from A2U12 and A2U15):

NOTE

“RANGE HOLD” must be **ON** during this test.

Table 8-8. A2U2 Analog Multiplexer Control Bits

| C1 U2(15) | C12 U2(16) | C11 U2(1) | FUNCTION |
|-----------|------------|-----------|----------------------------|
| 0 | 0 | 0 | Freq A, Manual Trigger Adj |
| 0 | 0 | 1 | DAC |
| 0 | 1 | 0 | Freq A, Manual Trig Preset |
| 0 | 1 | 1 | Diagnostic #33 (-5.2V) |
| 1 | 0 | 0 | Freq A, Auto Adjust |
| 1 | 0 | 1 | SLEW Rate A, f |
| 1 | 1 | 0 | Freq A, Auto Preset |
| 1 | 1 | 1 | SLEW Rate A, ∞ |

CAUTION

The assemblies and components involved in the following steps are all static sensitive, and should be handled at a static free work area, and in accordance with approved procedures.

8-350. If these bits are not set properly, check the Front End latch controls A2U15 and U12, by enabling Diagnostics #3 and #4.

8-351. Front End Latch Control Troubleshooting

8-352. Diagnostics #3 and #4 are designed to aid in the troubleshooting of A2U15 and U12, and related circuitry, including A3K1 in the standard front end (A3).

8-353. They are also used to troubleshoot the latches of the Option 040 programmable front end input, A11U16, U17, U18 and U24, and the related circuitry, including A12K1 through K9.

8-354. To enable Diagnostic #3, press: SCALE, SMOOTH, 9, 9, ENTER; wait 5 seconds, then press: SCALE, 3, ENTER. The 5335A will display: 'dIAG 03'.

8-355. Diagnostic #3 sets the A2U15 and A1U12 latches output to a TTL 'LOW'. With a logic probe oscilloscope, or a voltmeter, verify the state of the latches output per Table 8-9.

Table 8-9. A2 Troubleshooting A2U12 and A2U15

| REF. DESIG. | PIN # | NOMENCLATURE | DIAG. #3 | DIAG. #4 |
|-------------|-------|--------------|----------|----------|
| A2U15 | 1 | +5V | | |
| | 2 | C1 | Low | High |
| | 3 | D0 | 1.45V | 1.45V |
| | 4 | D1 | 1.45V | 1.45V |
| | 5 | C2 | Low | High |
| | 6 | D2 | 1.45V | 1.45V |
| | 7 | C3 | Low | High |
| | 8 | GND | | |
| | 9 | *U697 | 4.5V | 4.5V |
| | 10 | C4 | Low | High |
| | 11 | D3 | 1.45V | 1.45V |
| | 12 | C5 | Low | High |
| | 13 | D6 | 1.45V | 1.45V |
| | 14 | D7 | 5.0V | 5.0V |
| | 15 | C6 | Low | High |
| | 16 | +5V | | |
| A2U12 | 1 | +5V | | |
| | 2 | C7 | Low | High |
| | 3 | D0 | 1.45V | 1.45V |
| | 4 | D1 | 1.45V | 1.45V |
| | 5 | C8 | Low | High |
| | 6 | D2 | 1.45V | 1.45V |
| | 7 | C9 | Low | High |
| | 8 | GND | | |
| | 9 | *HA50 | 4.5V | 4.5V |
| | 10 | C10 | Low | High |
| | 11 | D3 | 1.45V | 1.45V |
| | 12 | C11 | Low | High |
| | 13 | D4 | 1.45V | 1.45V |
| | 14 | D5 | 1.45V | 1.45V |
| | 15 | C12 | Low | High |
| | 16 | +5V | | |

* = FREERUN Signature [START, STOP, CLOCK $\overline{\text{CK1}}$]

8-356. To enable Diagnostic #4, press: SCALE, 4, ENTER. This diagnostic set the latches output to a TTL "HIGH"; verify their state per the previous table.

8-357. To check out the relay driver A2Q1, exit diagnostic mode by pressing **FREQ A**. Verify the voltages in both common (COM A) and separate as shown in Figure 8-62.

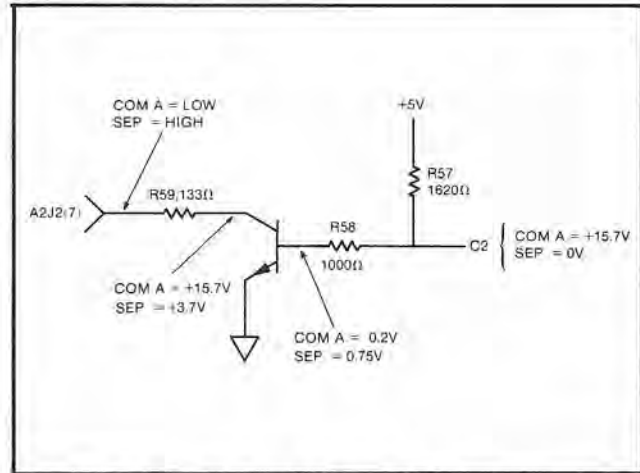

Figure 8-62. Relay Driver A2Q1 Voltage

8-358. A2U16 is an octal buffer that is used to send the status of certain front panel switches to the processor. To verify its operation, enable Diagnostic #5 by pressing:

SCALE, SMOOTH, 9,9, ENTER (then wait about 5 seconds)
press: SCALE, 5, ENTER

8-359. This diagnostic tests each of the 5335A front end data switches:

- Channel AX10 & BX10
- Channel A & B slopes
- Channel A & B preset
- COM A
- AUTO TRIG

NOTE

Channel A & B 1M ohms/50 ohms and AC/DC switches are not tested.

8-360. With Table 8-10 verify A2U16 inputs change state when appropriate switch is enabled:

Table 8-10. Troubleshooting A2U16 Signatures

| PIN | A2U16 | FUNCTION |
|-----|-----------------------------------|----------------------|
| *1 | 7HA6 | Clock Enable |
| 2 | OFF=HIGH ON=LOW | Auto Enable |
| 3 | | D6 |
| 4 | \bar{f} HIGH (5V), f LOW (0V) | BSP ("B" slope) |
| 5 | | D3 |
| 6 | PRESET=5V, Not PRESET=0V | BPR ("B" PRESET) |
| 7 | | D4 |
| 8 | X1=5V, X10=0V | AAT ("A" Attenuator) |
| 9 | | D5 |
| 10 | | Ground |
| 11 | \bar{f} 5V, f 0V | ASP ("A" slope) |
| 12 | | D7 |
| 13 | Separate=5V, COM A=0V | ACM (COM A) |
| 14 | | D2 |
| 15 | X1=5V, X10=0V | BAT ("B" Attenuator) |
| 16 | | D1 |
| 17 | PRESET=5V, Not PRESET=0V | APR ("A" PRESET) |
| 18 | | D0 |
| *19 | 7HA6 | Clock Enable |
| 20 | | V _{cc} = 5V |

* FREERUN signature [START, STOP, CLOCK \bar{f} (CK1)]

8-361. Also verify that by pressing all of the tested switches (listed in Table 8-10) to the "IN" position, the 5335A display will respond as shown in Figure 8-63.

8-362. When a switch is active ("IN" position), the indicated display digit should light. When released ("OUT" position) the indicated display digit should blank out.

NOTE

This diagnostic is not operational with Option 040.

8-363. A2U14 is a three-to-eight decoder that clocks A2U15 and U12 Front End latch controls and A2U16 the front end switch buffer.

8-364. To verify that U14 is working properly, set the 5335A to its FREERUN mode. Follow the procedure in paragraph 8-408. Verify the signatures in Figure 8-64.

8-365. If A2U14 input signatures are not correct, trace back to the microprocessor system signature in A4; see paragraph 8-404. If input signatures are good, but output signatures are bad, suspect U15, U12, U16, and last, U14.

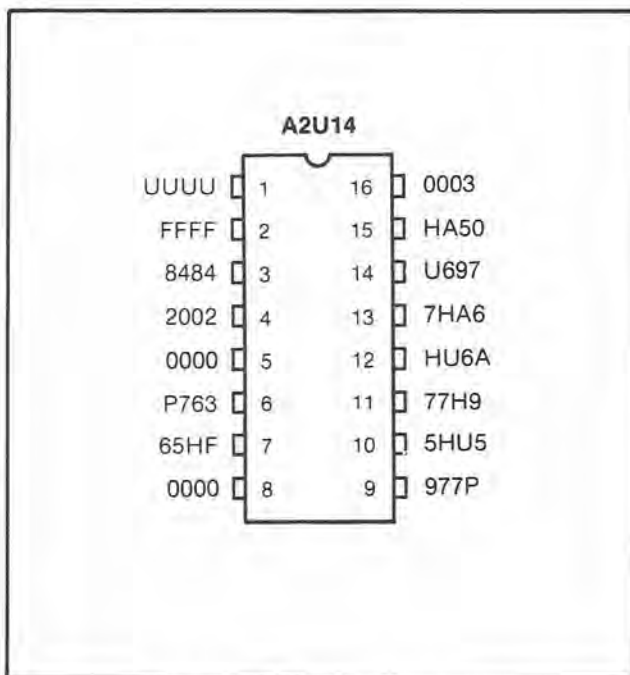

Figure 8-64. A2U14 Signatures

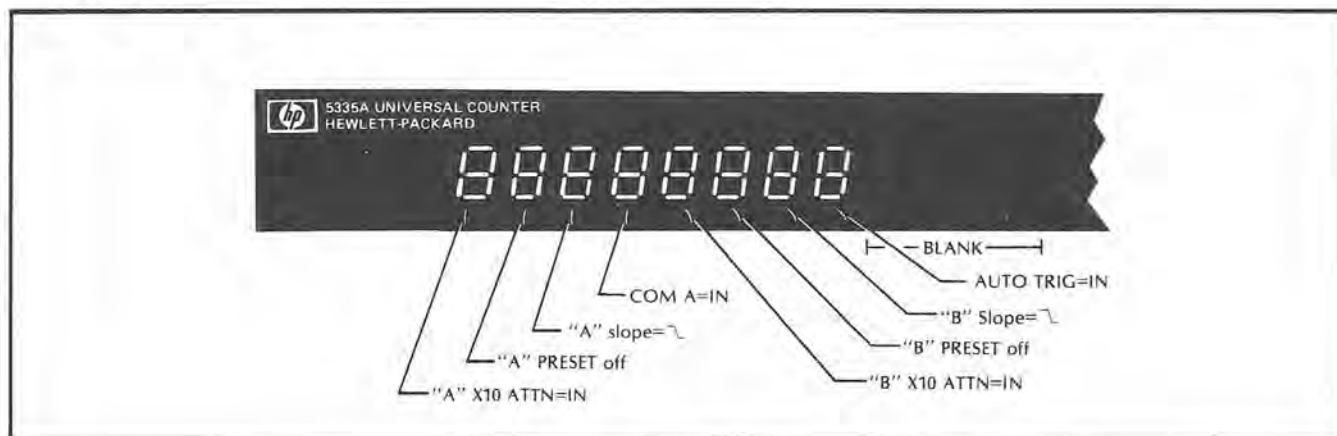

Figure 8-63. Diagnostic #5 Display Response

8-366. Trigger Level Voltmeter Troubleshooting

8-367. This section of A2 is composed of A2U4 multiplexer, U9 voltage-to-frequency converter; it is referenced to a very precise +10 volts supply from A1 power supply assembly. U13B uses the precise +10 volt reference to generate a -5 volt reference used in both U9 and U4. Refer to the Trigger Level Voltmeter Block Diagram, *Figure 8-65*.

NOTE

The +10V reference from A1 assembly should be verified to be within $\pm 0.01V$ before troubleshooting the Trigger Level DVM. Since if this reference is not correct, the trigger level DVM will not operate correctly.

8-368. To troubleshoot the Trigger Level DVM, first check U4 control bit pattern; Diagnostics #26 through #33 are used to set up these bit patterns. To enable these diagnostic, press:

- a. SCALE, SMOOTH, 9, 9, ENTER; wait 5 seconds.
- b. press: SCALE, (26 through 33), ENTER

8-369. After entering SUPER CHECK, select any one of the diagnostic desired. Verify the bit patterns of A2U4 per *Table 8-11*.

NOTE

“RANGE HOLD” must be set “ON” during these tests.

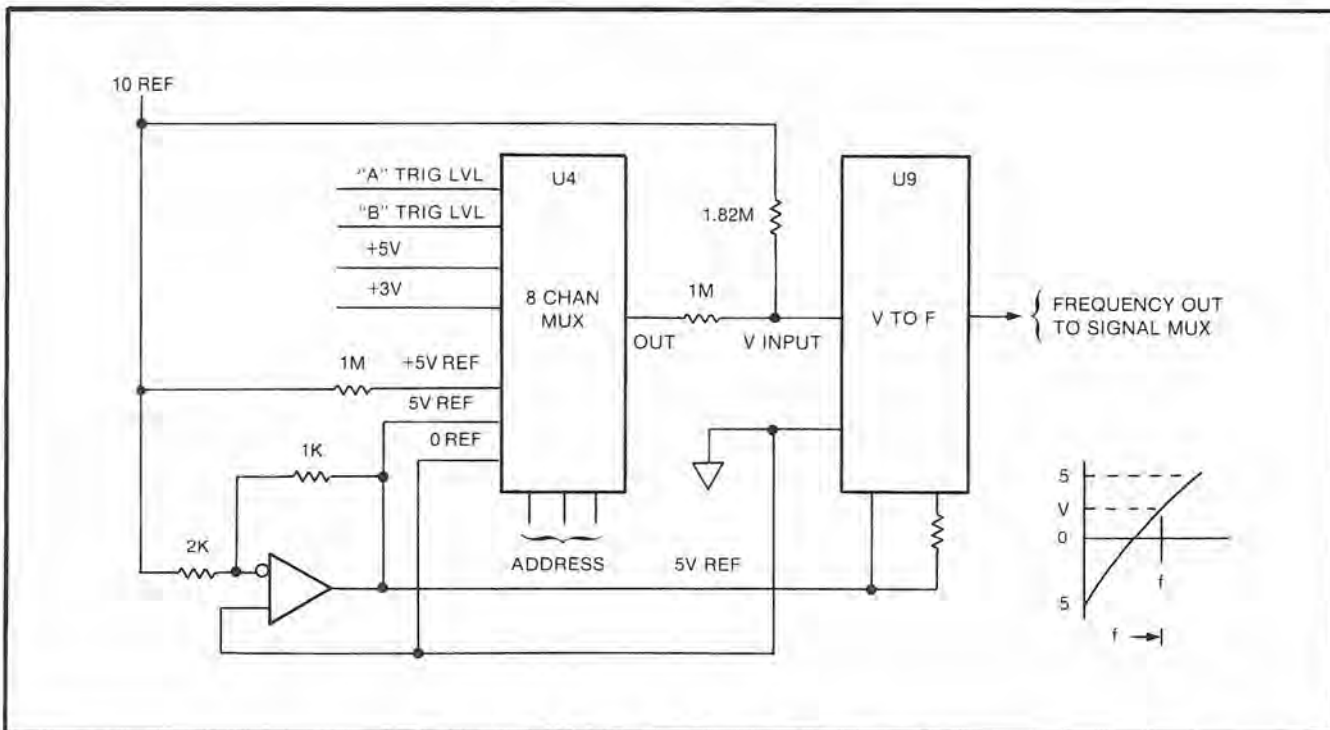

Figure 8-65. Trigger Level DVM Block Diagram

Table 8-11. A2U4 Analog Multiplexer Control Bits

| U4(15) | U4(16) | U4(1) | FUNCTION | DIAG | APPROXIMATE FREQUENCY |
|--------|--------|-------|--------------|------|--|
| 0 | 0 | 0 | Trig Lvl A | 29 | -5.2V 0V +5.2V 100 Hz 1.87 kHz 3.62 kHz |
| 0 | 0 | 1 | Trig Lvl B | 30 | Same as DIAG #29 |
| 0 | 1 | 0 | +5V Supply | 31 | 3.57 kHz |
| 0 | 1 | 1 | +5V Ref. | 28 | 3.56 kHz |
| 1 | 0 | 0 | +3V Supply | 32 | 2.83 kHz |
| 1 | 0 | 1 | Gnd. Ref. | 27 | 1.86 kHz |
| 1 | 1 | 0 | -5V Ref. | 26 | 170 Hz |
| 0 | 0 | 0 | -5.2V Supply | 33 | 90 Hz |

8-370. While in these diagnostics, with the RANGE HOLD function enabled, the 5335A will display the actual frequency that is counted in the MRC, out of A2U9(10). The approximate frequency given in the previous table will vary from unit to unit.

8-371. In Diagnostic #33 the microprocessor selects U4(4) which is TRIGGER LEVEL A, and A2U2(7), which is the -5.2 volt supply.

Table 8-12. U4 Input Voltage with Output Frequency at U8(1)

| Input Voltage (V) | Output Frequency (Hz) |
|-------------------|-----------------------|
| -5 | 162 |
| -4 | 515 |
| -3 | 874 |
| -2 | 1.18K |
| -1 | 1.52K |
| 0 | 1.86K |
| +1 | 2.21K |
| +2 | 2.54K |
| +3 | 2.88K |
| +4 | 3.22K |
| +5 | 3.56K |

NOTE

The output frequency will vary slightly from instrument to instrument. The above table is for information **ONLY**, and gives only an approximation of the voltage-to-frequency relationship.

8-372. If A2U4 bit patterns are verified and U4 input and output correlates, but no corresponding frequency per Table 8-12 out of U9(10), suspect U9, or level translator U8. If everything checks out through the Trigger Level DVM, then check out A2U7, the signal selector multiplexer and associated circuitry.

8-373. Signal Selector Multiplexer Troubleshooting

8-374. A2U7 is a dual 4-to-1 Multiplexer, and it selects which signal is counted into the MRC by way of the microprocessor; the control bits originates in the A2U12, and they are translated to ECL levels by U8. A12U11 is a divide-by-two flip-flop, controlled by bit C6, used to extend Channel A frequency range for Frequency A, Ratio A/B, and Ratio C/A functions. Refer to Figure 8-66.

8-375. The outputs of A2U7(2 & 15) as a function of control bits C9 and C10 per selected 5335A front panel function, are as listed in Table 8-13.

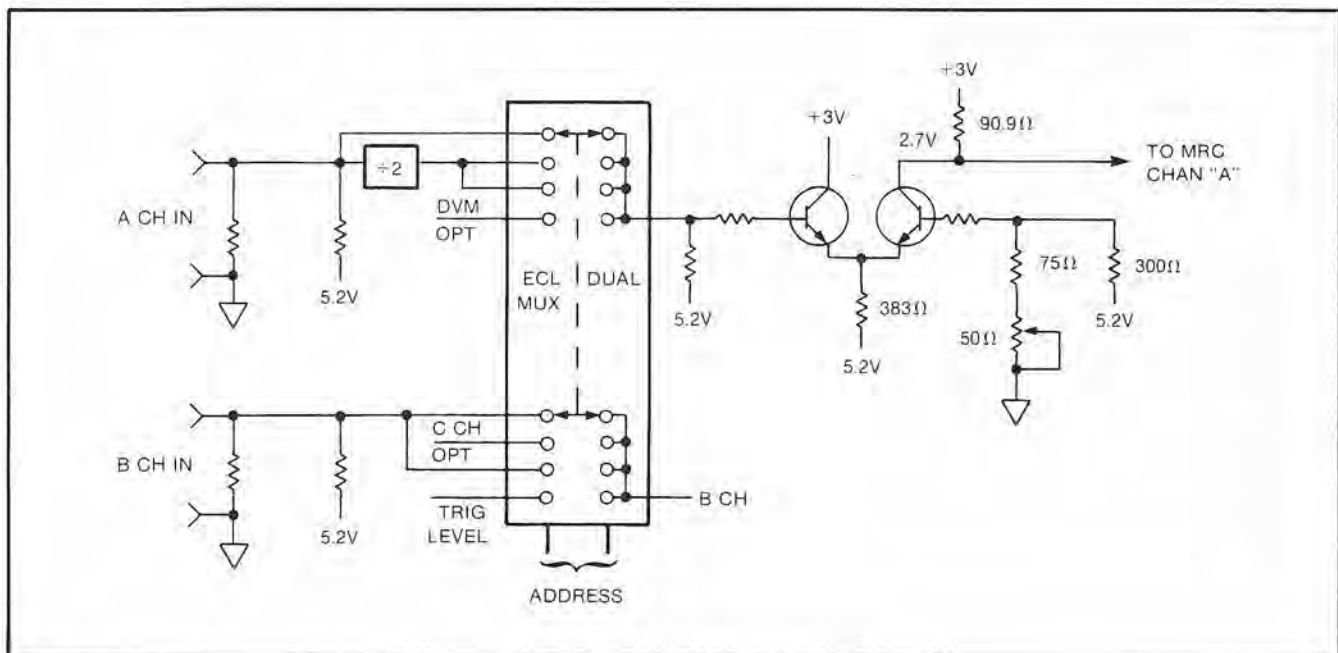

Figure 8-66. Signal Select Block Diagram

Table 8-13. A2U7 Outputs Related to Control Bits C6, C9 and C10

| FUNCTION | U15(15) C6 | U12(7) C9 | U12(10) C10 | U7(2) X | U7(15) Y |
|-----------------------|----------------------------|--------------|----------------|------------|-------------|
| FREQ A | 0 | 0 | 1 | A/2 | B |
| TIME A→B | 1 | 0 | 0 | A | B |
| TOT A | 1 | 0 | 0 | A | B |
| RATIO A/B | 0 | 0 | 1 | A/2 | B |
| FREQ C | 0 | 1 | 0 | | C/20 |
| 1/TIME A→B | 1 | 0 | 0 | A | B |
| PULSE A | 1 | 0 | 0 | A | B |
| RATIO C/A | 0 | 1 | 0 | A/2 | C/20 |
| PER A | 1 | 0 | 0 | A | B |
| RISE A (\int) | 1 | 0 | 0 | A | A |
| FALL A (\searrow) | 1 | 0 | 0 | A | A |
| SLEW A (\int) | 1/0 | 0/1 | 0/1 | A/DVM | B/Trig Lvl |
| SLEW A (\searrow) | 1/0 | 0/1 | 0/1 | A/DVM | B/Trig Lvl |
| DUTY CYCLE A | 1 | 0 | 0 | A | B |
| GATE TIME | SAME AS PRECEDING FUNCTION | | | | |
| TRIG LVL | 0 | 1 | 1 | DVM | Trig Lvl |
| VOLTS | 0 | 1 | 1 | DVM | Trig Lvl |
| PHASE A rel B | 0/1 | 0 | 1/0 | A/DVM | B/Trig Lvl |
| FREQ B (17) | 0 | 0 | 1 | A/2 | B |
| TIME B→A (18) | 1 | 0 | 0 | A | B |
| TOT A-B (19) | 1 | 0 | 0 | A | B |
| PULSE B (20) | 1 | 0 | 0 | A | B |

8-376. Prescaler Troubleshooting

8-377. A2U11 prescales input signal to Channel A by a factor of two. It is enabled by control bit C6, from U15(15). Refer to *Figure 8-67*.

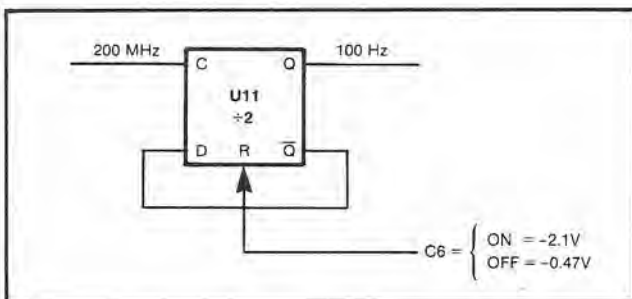

Figure 8-67. Prescaler A2U11 Reset (C6) Voltages

8-378. A3 INPUT AMPLIFIER BUFFER TROUBLESHOOTING

8-379. The A3 Amplifier Buffer Assembly consists of Input Offset buffer, the Bridge Limiter, the Peak Detectors, and the Amplifier Schmitt, for both channels A and B.

8-380. Input Offset Buffer Troubleshooting

8-381. The Input Offset Buffer is a split band amplifier, one path buffering the high frequency signals, and the other buffers the low frequency signals (below 10 kilohertz). To troubleshoot the Input Offset Buffer, check the **dc values** at key points, such as:

CHANNEL A

A3U4 pins 2, 3 and 6 (inputs and output),
A2U4 pins 1 and 8 (both sides of C35)
A3Q6, Q7, and Q8 (base emitter and collector)

8-382. This check **MUST** be done with **NO INPUT SIGNAL** and **AUTO TRIG** disabled; typical values are shown in *Figure 8-68*.

8-383. These dc values are **very** critical for maintaining the Q points of A3U4 (Channel A) and A3U3 (Channel B). If the values are not present, suspect A3U4, Q5, Q6, Q7, and Q8 (for Channel A). The Input Offset Buffer circuitry for Channel B is identical to Channel A, and it can be used for comparison basis.

CONDITIONS: a) MANUAL PRESET (AUTO TRIG OUT)
b) NO INPUT SIGNAL

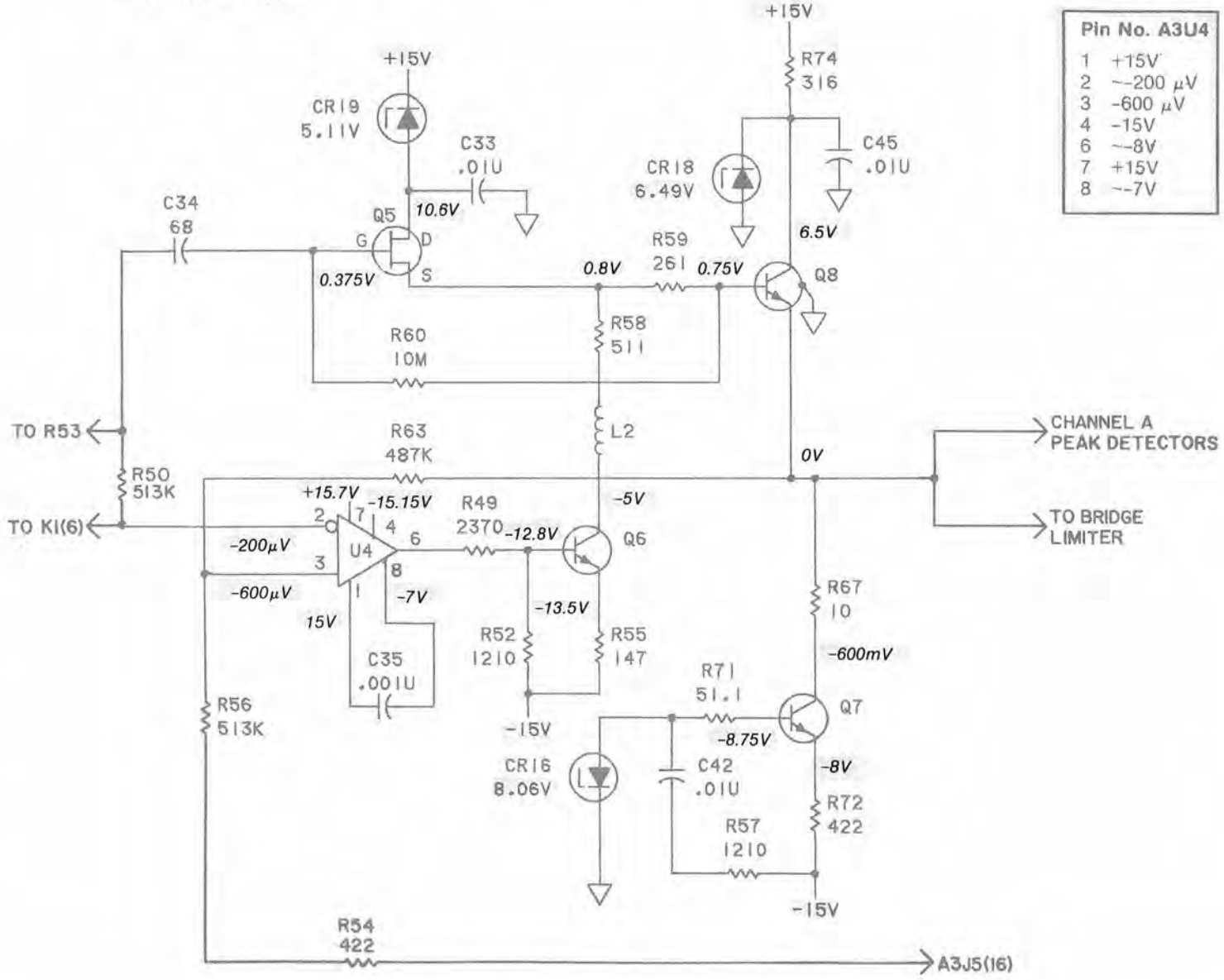

| Pin No. A3U4 | |
|--------------|---------|
| 1 | +15V |
| 2 | -200 μV |
| 3 | -600 μV |
| 4 | -15V |
| 6 | -8V |
| 7 | +15V |
| 8 | -7V |

Figure 8-68. Channel A Input Buffer DC Voltages

8-384. Peak Detectors Troubleshooting

8-385. The Peak Detector circuitry is designed to be used during the AUTO TRIG mode only; they are used to detect the maximum amplitude of the input signal, and the microprocessor will figure out the 10%, 50% and 90% points of input signal, through A2U2 and A2U10. There are two peak detectors per channel: a positive and a negative peak detector. During manual mode of operation, the positive and negative peak detectors are tied to ± 5.2 volts, respectively. The diodes used in the peak detectors are a closely matched set. A set of four matched peak detector diodes are available from Hewlett-Packard (see Section VI).

8-386. The peak detectors in the A3 assembly complements the channels A and B Trigger Level selector multiplexers, and the peak detector enabling circuitry, which are located in the A2 Amplifier Support assembly. See Figure 8-69.

8-387. The peak detector circuitry is contained in two assemblies: in A3 Amplifier Buffer assembly and in A2 Amplifier Support assembly. The peak detectors themselves are located in the A3 assembly. The signals that enable and disable the peak detectors originate on the A2 assembly, U15 through U1A, B, C, and D.

Table 8-14 lists the signals that control the peak detectors.

Table 8-14. Peak Detector Control Signals

| PEAK DETECTOR CONDITION A2U1 (PIN) | ANE (8) | APE (14) | BNE (1) | BPE (7) |
|---------------------------------------|---------|----------|---------|---------|
| ENABLED | -12.5V | +15.0V | -12.5V | +15.0V |
| DISABLED | +5.2V | -5.2V | +5.2V | -5.2V |

ANE = "A" NEGATIVE ENABLE (Enables Channel A Positive Peak Detector)
 APE = "A" POSITIVE ENABLE (Enables Channel A Negative Peak Detector)
 BNE = "B" NEGATIVE ENABLE (Enables Channel B Positive Peak Detector)
 BPE = "B" POSITIVE ENABLE (Enables Channel B Negative Peak Detector)

8-388. A3 Troubleshooting Accessories

8-389. To facilitate the troubleshooting of the A3 assembly (outside the counter) procure the following accessories:

- a. Two multiribbon cable assembly, P/N 8120-2463.
- b. Two 50-ohm cable assembly, P/N 05335-60112.
- c. Two SMC male-to-male adapter, P/N 1250-0827.

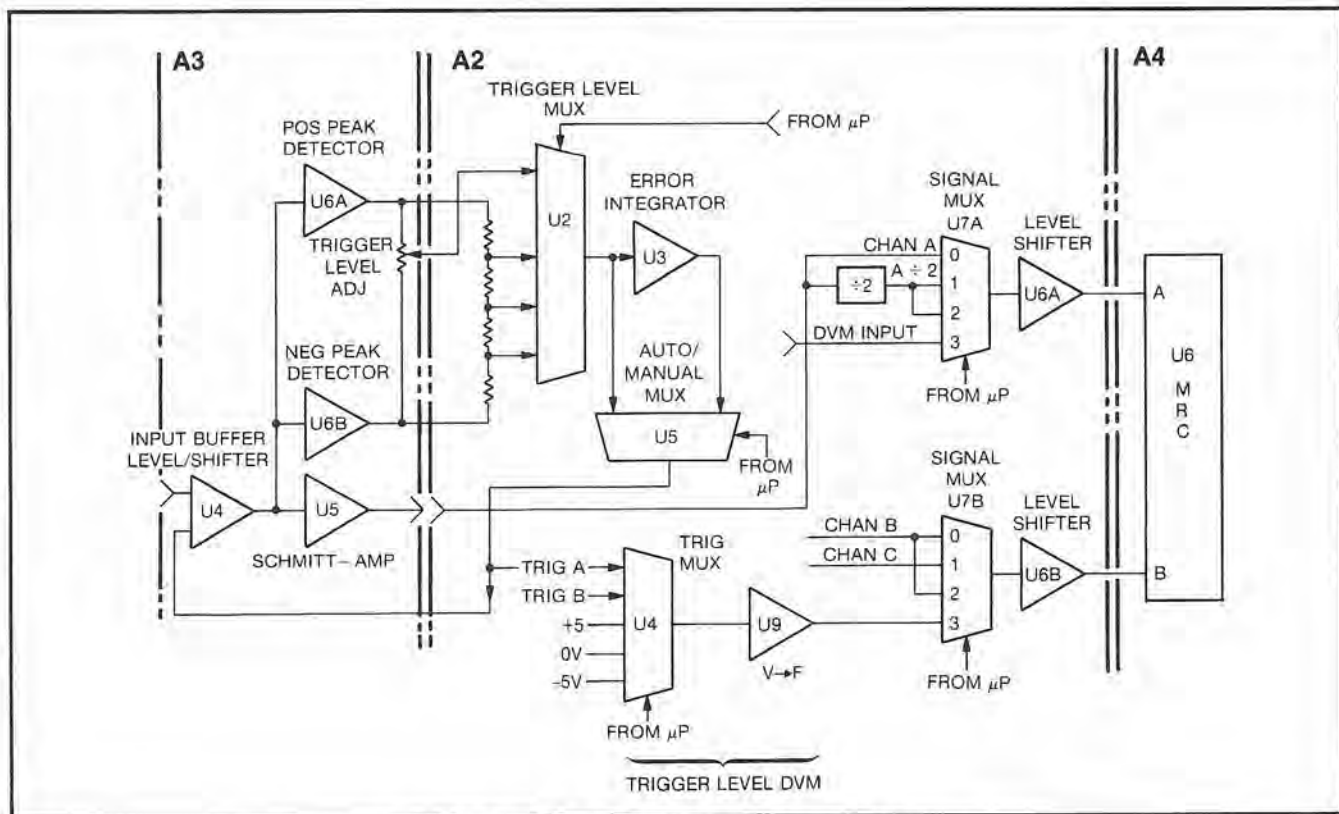

Figure 8-69. Peak Detector Block Diagram A2-A3-A4

8-390. A3 Troubleshooting Out-of-Cabinet Setup

- Remove the A3 assembly from mainframe.
- Replace both multiribbon cable assembly 8120-2867 with longer version, P/N 8120-2463.
- Connect two 50-ohm cable assemblies end-to-end, P/N 05335-60112, with a SMC male-to-male adapter, P/N 1250-0827, for both channels A and B. These new connections will facilitate access to key points in the A3 assembly.

8-391. Peak Detectors in Manual Mode Troubleshooting

8-392. To troubleshoot the Peak Detectors, first check their operation in MANUAL mode. To do this, set the 5335A Auto Trigger mode to the OFF condition. Enable TRIG LVL function, and vary the front panel trigger level controls for both channels from ccw to cw positions. The displayed voltage for both channels should be between ± 5.2 volts; the key point is that both peak detectors should display the same readings, ± 10 millivolts.

8-393. In the manual mode, the peak detector outputs are tied to ± 5.2 volts; Verify this voltage at A3J1(16) or at A2U5(8), the ATL line, by varying the channel A trigger level pot on the 5335A front panel. If voltage is not present, back trace through A2U5A, A2U2 (channel A trigger level selector), to the APL line.

8-394. Also, verify that peak detectors are truly disabled; check A2U1(8), (14), (1), (7).

8-395. When checking the forward voltage drop of the peak detector diodes, verify that all diodes within each peak detector are matched to within less than 5 mV; If they are not, replace all three diodes.

8-396. Peak Detectors in Auto Mode Troubleshooting

8-397. To troubleshoot peak detectors in AUTO mode, apply a 1 kHz square wave of 500 mV p-p to the 5335A INPUT A. See Figure 8-70. Set the 5335A to AUTO TRIG, and COM A, 50 ohms, X1, dc coupling.

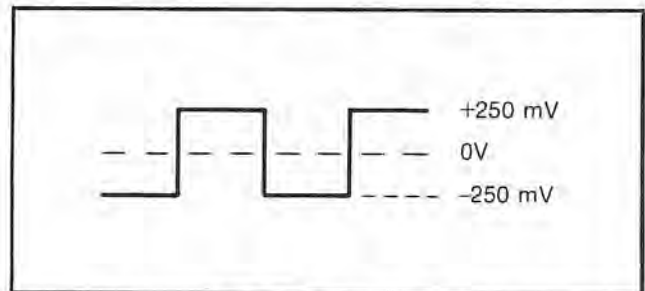

Figure 8-70. Peak Detector Test Signal

a. Enable TRIG LVL function; rotate the trigger level controls for channel A and B to the ccw position (not in PRESET). Observe the 5335A displaying the peak of signal, $-0.24V \pm 0.01V$. Rotate the trigger level pots to the full cw position and verify a display of $(+0.24 \pm 0.01)$ volt.

b. Ground the ATL line (connect a jumper from either side of A3R54 to ground). This will force a feedback trigger level of zero volts to A3U4(3), and remove the effect of the peak detectors back into A3U4.

c. Rotate both trigger level pots to the ccw position.

d. Verify the APD line (channel A positive peak detector output) and AND line (channel A negative peak detector output), reflect the true peaks of signal, i.e., about $+230 \text{ mV} \pm 10 \text{ mV}$, and $-230 \text{ mV} \pm 10 \text{ mV}$, respectively. If this voltage is not present, check the voltages of A3U6 per Figure 8-71 (in volts).

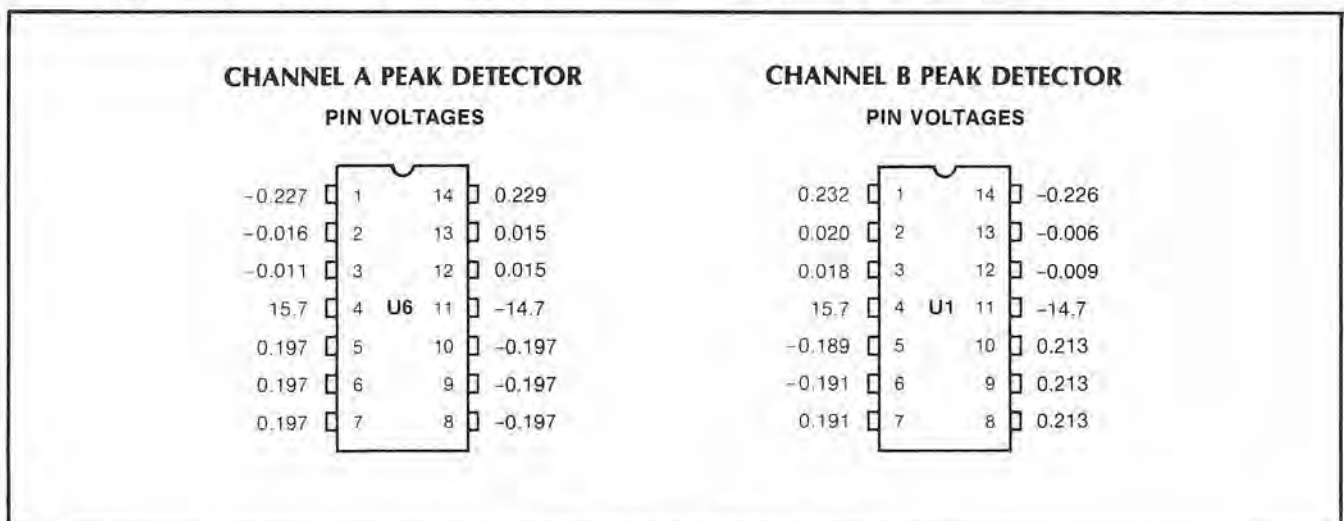

Figure 8-71. A3U6 and A3U1 Pin Voltages

e. To obtain the readings of A3U1 as listed above, ground the BTL line (connect a jumper from either side of A3R38 to ground).

f. If these voltages are not attained, verify that the peak detectors are fully enabled by A2U1. If they are not fully enabled, suspect A2U1. If they are enabled by proper voltage, try adjusting peak detectors; refer to adjustment procedure in Section V.

g. If they cannot be adjusted, suspect A3U6; also replace matched set of diodes A3CR24, CR25 and CR28 ("A" positive peak detector), A3CR26, CR27, CR29 ("A" negative peak detector), C51, C52, C58, C57, C53, C55.

8-398. Schmitt Amplifier Troubleshooting

8-399. The best way to verify the proper operation of the Schmitt amplifier is by checking its hysteresis. Refer to Input Amplifier adjustment procedure. The amplifier must be adjustable to between 18 and 20 mV peak-to-peak; Refer to paragraphs 8-33 and 8-34 if amplifier cannot be adjusted to these limits; also suspect A3U5 (Channel A) or A3U2 (Channel B).

8-400. Bridge Limiter Troubleshooting

8-401. The bridge limiter is composed of A3CR20-CR23 and it serves to protect the A3U5 Schmitt amplifier (Channel A) from overvoltage without distorting the signal on the receiving end.

8-402. Check that the forward voltage drop across each diode are matched within less than 5 mV of each other.

8-403. The four diodes are a closely matched set, and if one or more diode has to be replaced, all four MUST be replaced; P/N 05335-80003 is a set of four matched diodes set-up for replacement.

8-404. A4 MAIN LOGIC TROUBLESHOOTING

8-405. The A4 Main Logic Assembly contains the microprocessor system, Multiple Register Counter (MRC), the Start and Stop Interpolators, the Time Base circuits, and the GATE OUT circuits. Refer to Figure 8-72.

8-406. Microprocessor System Troubleshooting

8-407. The system is composed of U28 microprocessor, U22 and U23 ROM's, U25 and U26 RAM's, bidirectional data line buffers U16, U24, and U27 address buffer.

8-408. To troubleshoot the microprocessor system, we use signature analysis with microprocessor set up in the FREERUN mode. Use the following procedure to take microprocessor signatures:

a. Connect the Signature Analyzer START, STOP, and CLOCK leads to the appropriate test pins next to the A4U28 Microprocessor. Set the START, STOP, and CLOCK keys on the Signature Analyzer to the negative edge ($\bar{\Delta}$). Ensure that the Signature Analyzer CLOCK Pod lead is connected to the test pin marked "CK1".

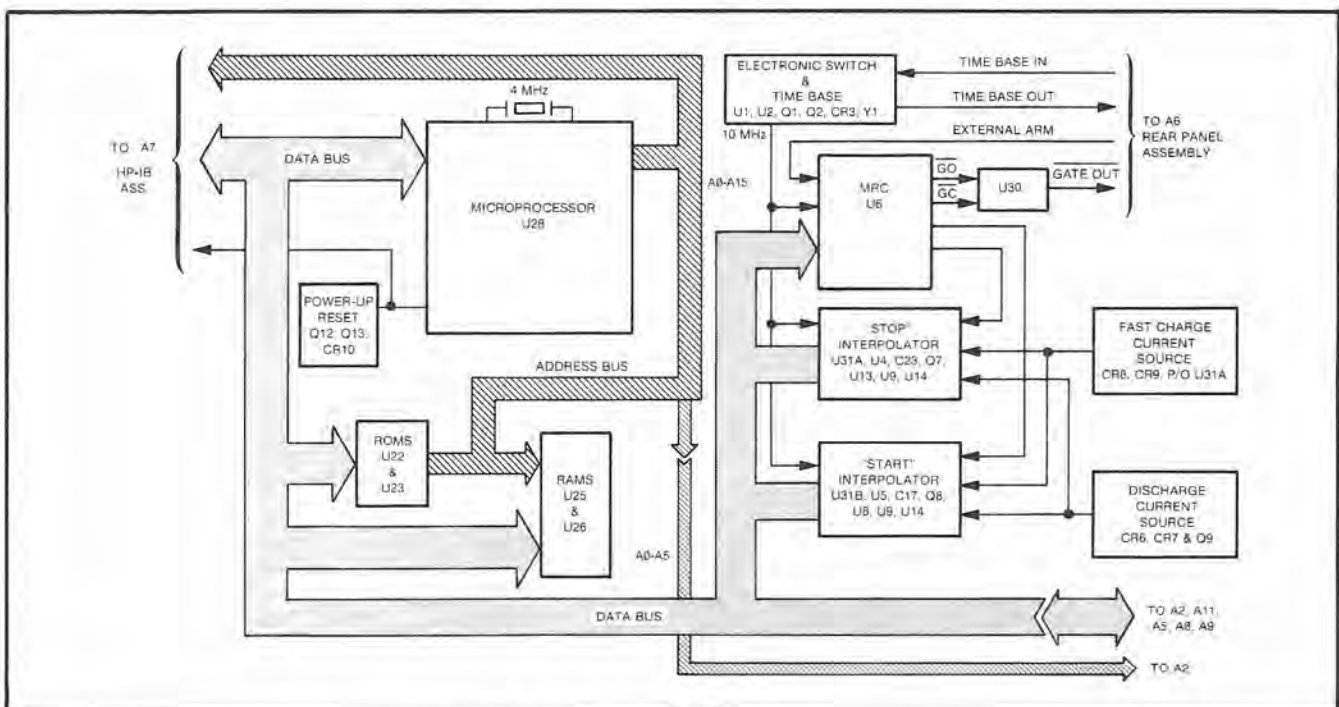

Figure 8-72. A4 Block Diagram

b. Connect a jumper between the test points marked "SA" and "G", located between A4U12 and A4U21. This will set the Microprocessor in the "FREE-RUN" mode.

c. Press the 5335A power key to STBY then ON. The first signature to be verified is +5V signature

(0003). If this signature is correct, it signifies proper connection of the signature analyzer.

d. Verify the A4U28 Signatures in Table 8-15.

e. Verify signatures in Table 8-16.

Table 8-15. A4U28 Signatures, Logic States, and Voltages

| PIN | STATUS | PIN | STATUS | PIN | STATUS | PIN | STATUS |
|-----|----------------------------------|-----|----------------------|-----|----------|-----|-----------------|
| 1 | GND | 11 | A2 8484 | 21 | GND | 31 | D2 HI |
| 2 | HALT HI (+5V) | 12 | P763 | 22 | A12 4FCA | 32 | D1 HI |
| 3 | MR 0003-C | 13 | A4 IUSP | 23 | A13 4868 | 33 | D0 HI |
| 4 | IRQ HI | 14 | A5 0356 | 24 | A14 9UPI | 34 | R/W HI |
| 5 | VMA HI | 15 | A6 U759 | 25 | A15 0001 | 35 | +5V |
| 6 | NMI HI | 16 | A7 6F9A | 26 | D7 LO | 36 | RE GND |
| 7 | BA LO | 17 | A8 7791 | 27 | D6 HI | 37 | E 1 MHz CLOCK |
| 8 | +5V | 18 | A9 6321 | 28 | D5 LO | 38 | 4 MHz Sine wave |
| 9 | A0 UUUU | 19 | A10 37C5 | 29 | D4 HI | 39 | 4 MHz Sine wave |
| 10 | A1 FFFF V _{CC} =0003 | 20 | A11 6U28 GND=0000 | 30 | D3 HI | 40 | Reset HI |

NOTE: Normal Operation, RE #36 should be high.

Table 8-16. A4 Signatures

| PIN | U10 | U11 | U12 | U19 | U20 | U21 | PIN |
|-----|---------|---------|----------------|---------|---------|----------|-----|
| 1 | 9AAC | P50C | 0003 | FFFF | 4FC9 | 0003 | 1 |
| 2 | 0356 | 4868 | 0000 | 8484 | P50C | 0003-C* | 2 |
| 3 | U759 | 9UP1 | 4FCA | P763 | P50C | 0000-C* | 3 |
| 4 | 4534 | 0000 | 4FC9 | 0000-C* | 0003-C* | 00003-C* | 4 |
| 5 | 2002 | 0003 | 01H7 (099C) | PU4A | 4FCA | 0000 | 5 |
| 6 | PU4A | 0003 | 01H4 | 0003 | 3714 | 0003 | 6 |
| 7 | 01H4 | 0000 | 0000 | 27FP | 0000 | 0000 | 7 |
| 8 | 0000 | 0000-C* | 099C (0000) | 0000 | 48C7 | 0000-C* | 8 |
| 9 | 3282 | 01H4 | 01H7 | 7FH1 | UHU5 | 0003-C* | 9 |
| 10 | AH63 | 01H7 | 0003 | FH24 | P50C | 0003 | 10 |
| 11 | 7APA | 4FCA | 0000 | H27U | 0003 | 0003 | 11 |
| 12 | P508 | 6F9A | 0003-C* | 27F0 | 9AAC | 48C7 | 12 |
| 13 | 9UP1 | UHU5 | 0000-C* | 7F30 | 6F9A | 0000 | 13 |
| 14 | 4868 | 0003 | 0003 | F33U | 0003 | 0003 | 14 |
| 15 | 0000-C* | | | 33F2 | | | 15 |
| 16 | 0003 | | | | | | 16 |
| 17 | | | | | | | 17 |
| 18 | | | | UHU5 | | | 18 |
| 19 | | | | | | | 19 |
| 20 | | | | | | | 20 |
| 21 | | | | | | | 21 |
| 22 | | | | | | | 22 |
| 23 | | | | | | | 23 |
| 24 | | | | | | | 24 |

Signatures with "C" are active nodes and are not V_{CC} or "ground".

Table 8-16. A4 Signatures (Continued)

| PIN | U22 | U23 | U24 | U25 | U26 | U27 | PIN |
|-----|------|------|-----------------------|----------|------|------|-----|
| 1 | 6F9A | 6F9A | 0003 | P763 | P763 | GND | 1 |
| 2 | U759 | U759 | X | 8484 | 8484 | 4FCA | 2 |
| 3 | 0356 | 0356 | X | FFFF | FFFF | FFFF | 3 |
| 4 | 1U5P | 1U5P | X | UUUU | UUUU | 6F9A | 4 |
| 5 | P763 | P763 | X | 0356 | 0356 | UUUU | 5 |
| 6 | 8484 | 8484 | X | U759 | U759 | 0356 | 6 |
| 7 | FFFF | FFFF | X | 6F9A | 6F9A | 8484 | 7 |
| 8 | UUUU | UUUU | X | GND | GND | 1U5P | 8 |
| 9 | X | X | X | 3714 | 3714 | P763 | 9 |
| 10 | X | X | GND | 3714 | 3714 | GND | 10 |
| 11 | X | X | 0000 | X | X | P763 | 11 |
| 12 | GND | GND | 0003 | X | X | 1U5P | 12 |
| 13 | X | X | 0000 | X | X | 8484 | 13 |
| 14 | X | X | X | 0003 | X | 0356 | 14 |
| 15 | X | X | 0003 | 7791 | 7791 | UUUU | 15 |
| 16 | X | X | 0003 | 0003 | 0003 | 6F9A | 16 |
| 17 | X | X | 0003 | 1U5P | 1U5P | FFFF | 17 |
| 18 | 6U28 | 6U28 | 0003 | 0003 | 0003 | 4FCA | 18 |
| 19 | 37C5 | 37C5 | 0003 | | | GND | 19 |
| 20 | AH63 | 3282 | +5V | | | +5V | 20 |
| 21 | 4FCA | 4FCA | | | | | 21 |
| 22 | 6321 | 6321 | | | | | 22 |
| 23 | 7791 | 7791 | | | | | 23 |
| 24 | +5V | +5V | V _{CC} =0003 | GND=0000 | | | 24 |

X=Don't care signatures (Unstable)

f. Verify the following signatures on A7 (HP-IB Logic Assembly). Ensure the Signature Analyzer CLOCK (CK1), START, and STOP keys are negative ($\bar{}$).

| TEST POINT | SIGNATURES |
|------------|------------|
| A7U1(4) | P546 |
| 7U2(5) | U867 |
| A7U2(11) | 7APA |

g. If the above signatures are correct at the specified key points, proceed to check the ROMs.

8-409. Use the following procedure to test the ROMs (A4U22 and A4U23) using signature analysis, with the microprocessor set in the FREERUN mode.

a. Connect the Signature Analyzer START and STOP leads to the appropriate test pins next to the A4U28 microprocessor, marked "S". The CLOCK Pod lead should be connected to the test pin marked "CK2" (located next to A4U23), and to "CK3" (located next to AU22) when testing A4U22.

b. Set the Signature Analyzer keys as follows:

START and STOP $\bar{}$ (neg.)
CLOCK $\phantom{\bar{}}$ (pos.)

c. Connect a jumper between test points marked "SA" and "G", located between A4U12 and A4U21. This will set the processor in the "FREERUN" mode.

d. Verify the Table 8-17 signatures on the A4U23 ROM. Ensure the Signature Analyzer CLOCK (CK2) key is set ($\phantom{\bar{}}$) positive, and the START and STOP keys are set negative ($\bar{}$).

Table 8-17. A4U23 Signatures

| PIN NO. | DATA LINE | SIGNATURE |
|---------|-----------|-----------|
| 9 | 0 | F847 |
| 10 | 1 | UP57 |
| 11 | 2 | C058 |
| 13 | 3 | 3867 |
| 14 | 4 | 2C79 |
| 15 | 5 | 08C4 |
| 16 | 6 | FP12 |
| 17 | 7 | 5770 |

e. Verify the *Table 8-18* signatures on the A4U22 ROM. Ensure the Signature Analyzer CLOCK (CK3) key is set positive (┘), and the START and STOP keys are set negative (┘).

Table 8-18. A4U22 Signatures

| PIN NO. | DATA LINE | SIGNATURE |
|---------|-----------|-----------|
| 9 | 0 | 964C |
| 10 | 1 | 1F42 |
| 11 | 2 | 5A38 |
| 13 | 3 | F9A5 |
| 14 | 4 | U94H |
| 15 | 5 | 11F0 |
| 16 | 6 | C1C3 |
| 17 | 7 | 2PA0 |

f. If the signatures are correct, go to the next step for the Signature Analysis of the output ports in "STIMULUS" mode. If any signatures are incorrect, suspect a faulty data bus (check for shorts), A4U10 the 2-to-4 decoder, A4U12A and A4U12E the inverters, A4U21 and A4U24 the bidirectional buffers, A4U27 buffer, or A4U28 the microprocessor.

8-410. Troubleshooting the A4 Assembly Using "STIMULUS MODE" and Signature Analysis

8-411. Diagnostic #2 is designed to test all output ports. The circuitry is tested using signature analysis with the 5335A set in the STIMULUS MODE. To avoid mistakes in setting up the diagnostic, the input ports are not tested. The output ports tested in this procedure are:

- Gate Range/Output control flip-flops, A4U17 and A4U18.
- Keyboard/Display control latch, A5U4.
- Keyboard/Display Data latch, A5U5.
- HP-IB Data Output Ports, A7U1, A7U4, A7U7, and A14J3.
- DVM option control latch, A8U3.

8-412. One of the following two methods can be used to enable Diagnostic #2:

a. By software: If the processor can communicate with the keyboard press: SCALE, SMOOTH, 9, 9, ENTER. Wait 5 seconds, press: SCALE, 2, ENTER. The 5335A will display "dIAG 02", enabling the stimulus mode.

b. By hardware: Press the 5335A Power Switch to STBY. Place A6 on the HP-IB Address Switch (A14S1A6)

in the "1" position (UP). Connect a jumper between the two plated-through holes marked "1" located between A14J2 and A14A1 (marked "SW1"). Press the 5335A Power Switch ON. If the jumper has been connected properly all display annunciator lamps will turn ON and stay ON enabling the stimulus mode.

8-413. Signature Analysis of the 5335A in the STIMULUS MODE

8-414. Use the following procedure to perform STIMULUS MODE signature analysis:

a. Connect the Signature Analyzer START, STOP, and CLOCK leads to the appropriate test pins next to the A4U28 microprocessor chip. Set the START, STOP, and CLOCK keys on the Signature Analyzer to the negative edge (┘). Ensure that the Signature Analyzer CLOCK pod lead is connected to the test pin marked "CK1".

b. Verify the +5V characteristic signature is 6PCU. If so, the Signature Analyzer is connected properly.

c. Verify the following Key Signatures at the Output Ports:

- Gate Range/Output control flip-flops on A4 (Main Assy):

A4U18(9) A95H
 A4U18(11) 9558
 A4U17(9) A95H
 A4U17(11) 9558

- Keyboard/Display Control Latch on A5 (Keyboard and Display Assembly):

A5U4(2,7,10,15) 1A95
 A5U4(9) 4101

- Keyboard/Display Control Latch on A5 (Keyboard and Display Assembly):

A5U5(2,5,6,9,12,16,19) F1A9
 A5U5(11) 2F44

- HP-IB Data Output port on A7 (HP-IB Logic Assy) and A14J3 (HP-IB connector):

A7U1(29 through 36) 02A5
 A7U4(2,3,5,6,10,11,13,14) 02A5
 A7U7(2,3,5,6,10,11,13,14) 02A5
 A14J3(1 thru 4 & 13 thru 16) .. 02A5

- DVM Option Control Latch on A8 (DVM Assy):

A8U3(2,7,10,15) 95H2
 A8U3(9) H0F8

d. If any of these "key-point" signatures are not correct, proceed to back-trace the signatures. Sus-

pect the RAMS A4U25 or A4U26, the D flip-flops A4U17 or A4U18, or the microprocessor (A4U28). (Check for shorted components).

NOTE

To exit diagnostic #2 the 5335A POWER switch must be set to STBY.

8-415. START and STOP Interpolators Troubleshooting

8-416. The START and STOP Interpolators allow the 5335A to resolve measurements down to one nano-

second. Both interpolators utilize two current sources: a fast charge current source and a slow discharge current source (by a factor of about 200). Refer to Figure 8-73.

8-417. Special Diagnostic subroutines #11, #12, and #13 can be used to verify the proper operation, or to troubleshoot the START and STOP interpolators in the 5335A. Proper functioning of the analog portion of the interpolators is verified by observing waveforms at key points on the Main Logic Assembly (A4).

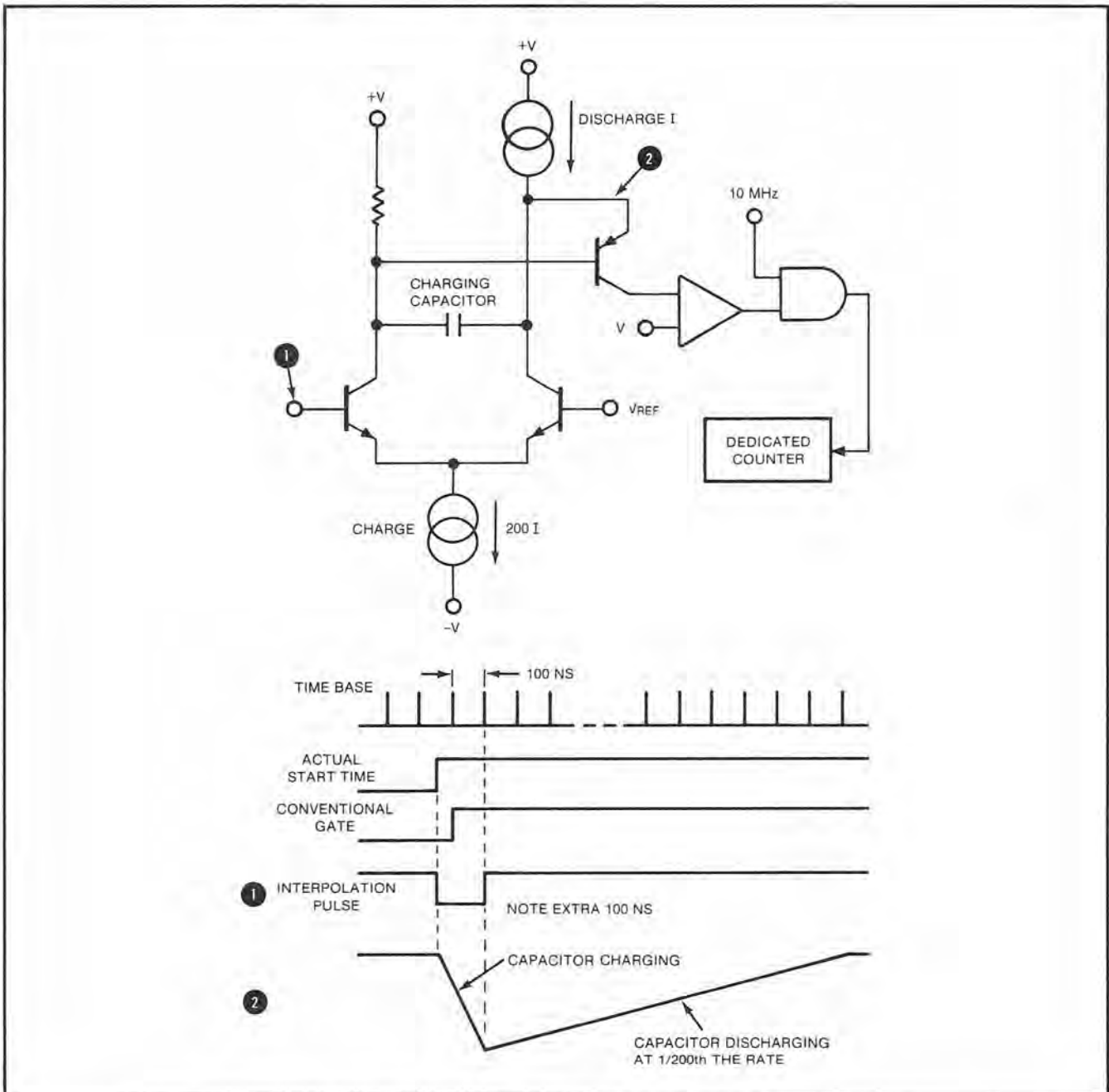

Figure 8-73. Simplified Interpolators Schematic

8-418. Diagnostic #11 is used exclusively for observing the waveforms at specified key points. The numbers in the interpolator counters are not displayed. The 5335A display will show: "DIAG 11".

8-419. Diagnostic #12 displays two groups of 3-digit numbers. The number on the left side of the display shows the count in the START interpolator, and the number on the right side of the display shows the count in the STOP interpolator. Both numbers should be approximately ± 10 counts of each other.

8-420. Diagnostic #13 also displays two groups of 3-digit numbers, showing the counts in both the START and STOP interpolators. The counts displayed should be approximately 26 to 86 counts less than the counts displayed by Diagnostic #12.

NOTE

The number displayed is the interpolator count minus 256. An 8-bit counter is used as a 9-bit counter in this mode; the ninth bit is assumed.

8-421. Both Diagnostics #12 and #13 can also be used to observe waveforms at specified points on the A4 Assembly. Since the circuitry for both the START and STOP interpolators is identical, the waveforms shown apply to both circuits.

8-422. To access Diagnostics #11, #12, or #13 put the 5335A in the diagnostic mode by calling up Special Function 99. This can be done by pressing the 5335A keys: SCALE, SMOOTH, 9, 9, ENTER. Wait 5 seconds before selecting the diagnostic, then to access one of the following diagnostics proceed as indicated:

Diagnostic #11, press: SCALE, 11, ENTER.

Diagnostic #12, press: SCALE, 12, ENTER.

Diagnostic #13, press: SCALE, 13, ENTER.

Refer to *Figure 8-74* through *8-79* for diagnostic waveforms.

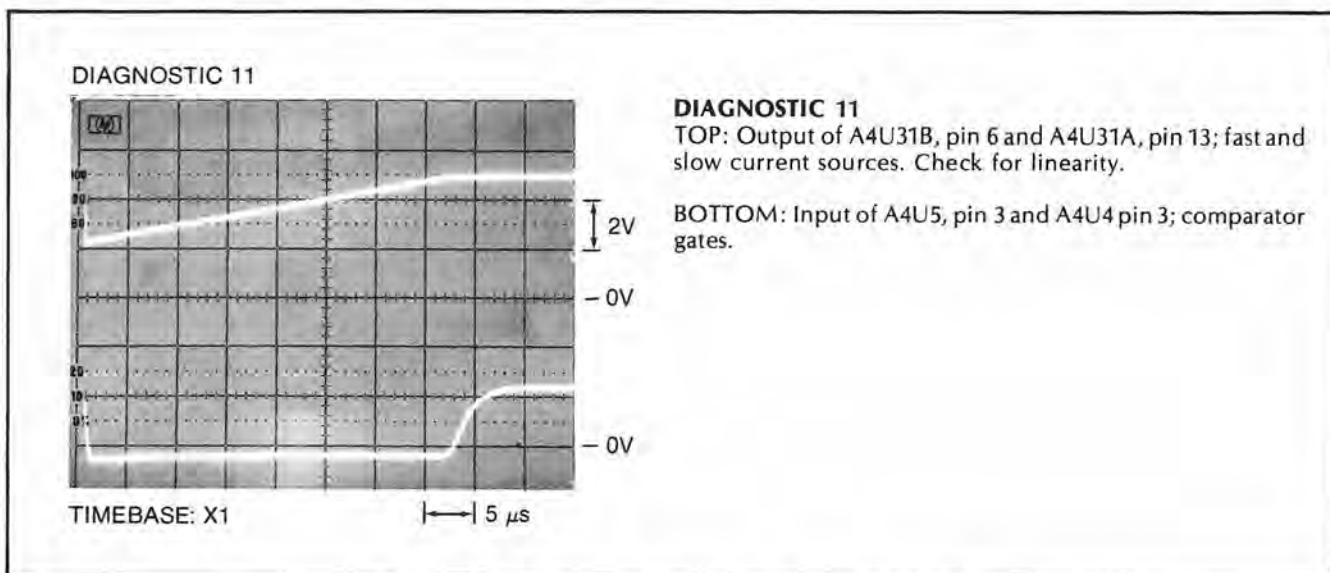

Figure 8-74. Diagnostic 11 Waveform, A4U31 and A4U5

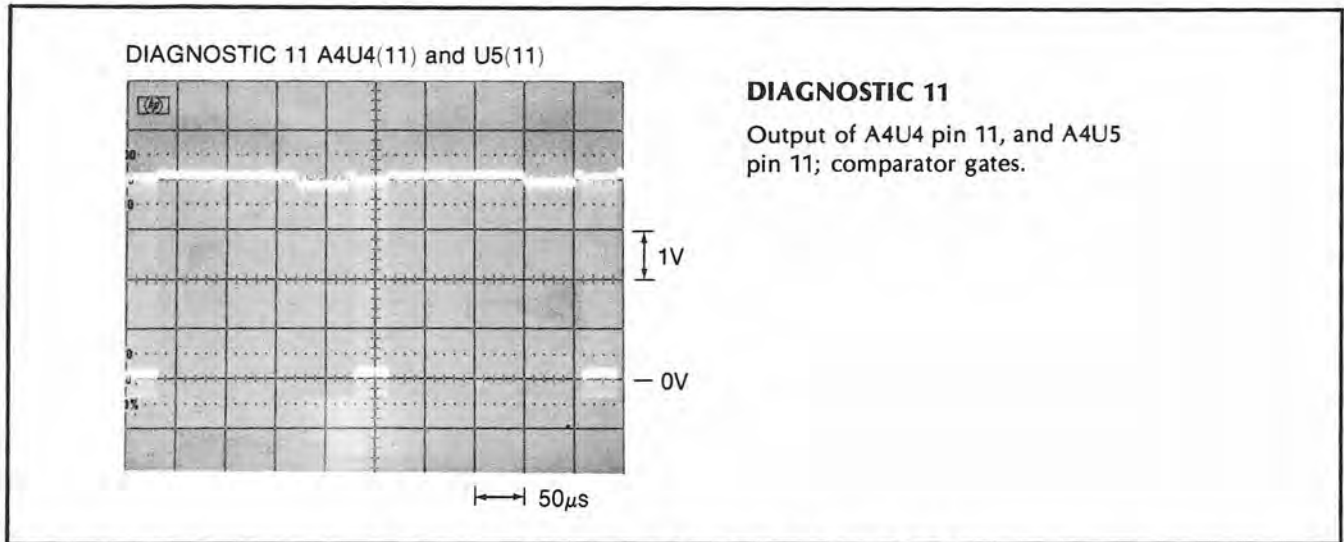

Figure 8-75. Diagnostic 11 Waveform, A4U4 and A4U5

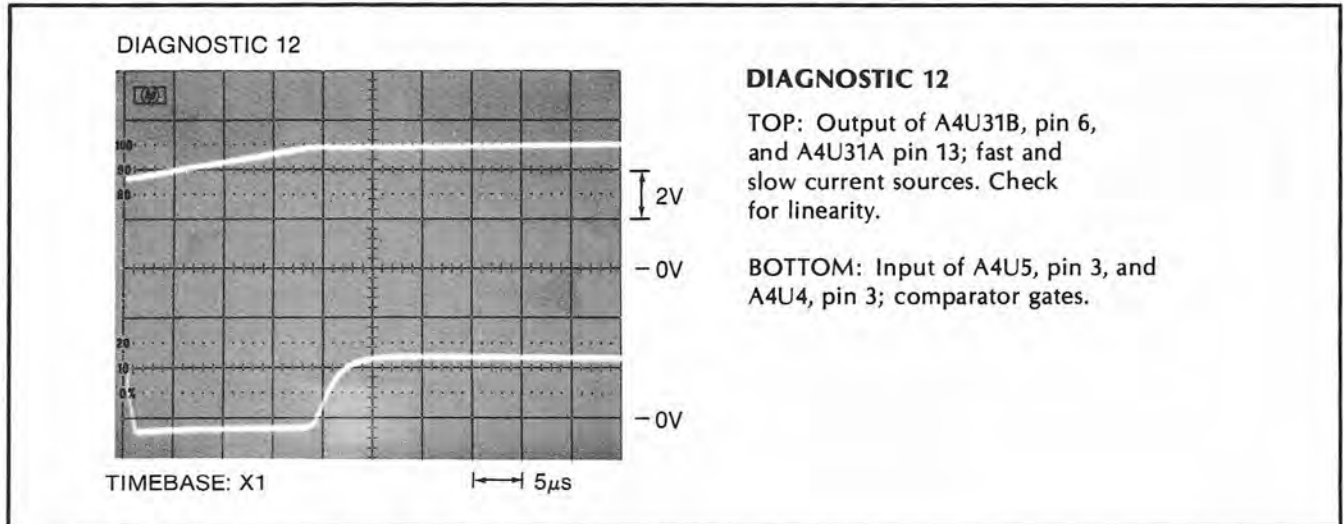

Figure 8-76. Diagnostic 12 Waveform, A4U31, A4U5, and A4U4

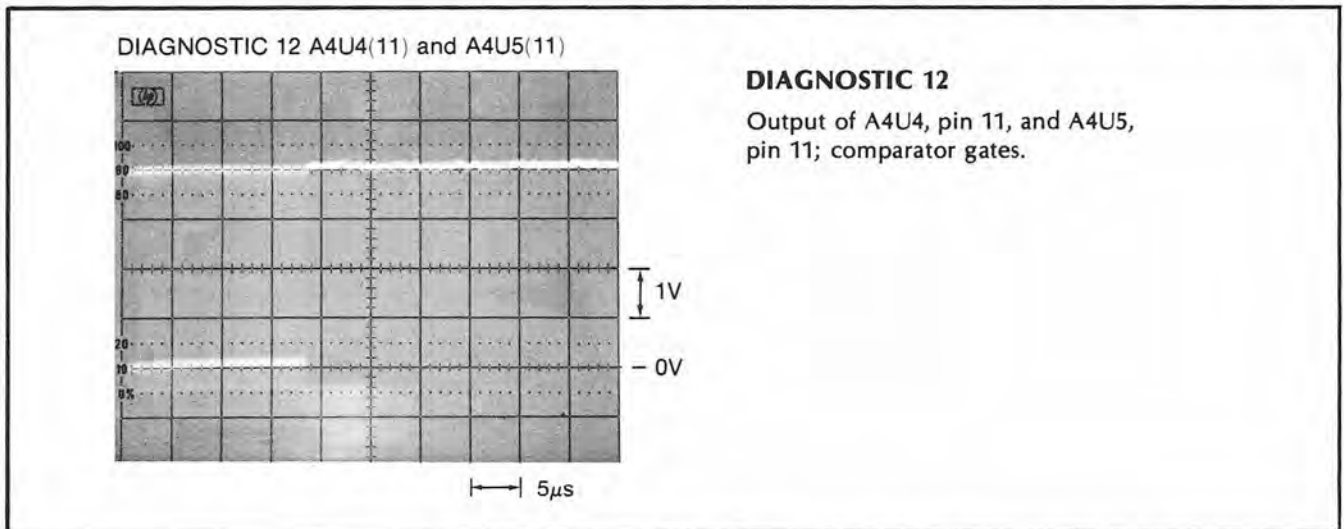

Figure 8-77. Diagnostic 12 Waveform, A4U5 and A4U4

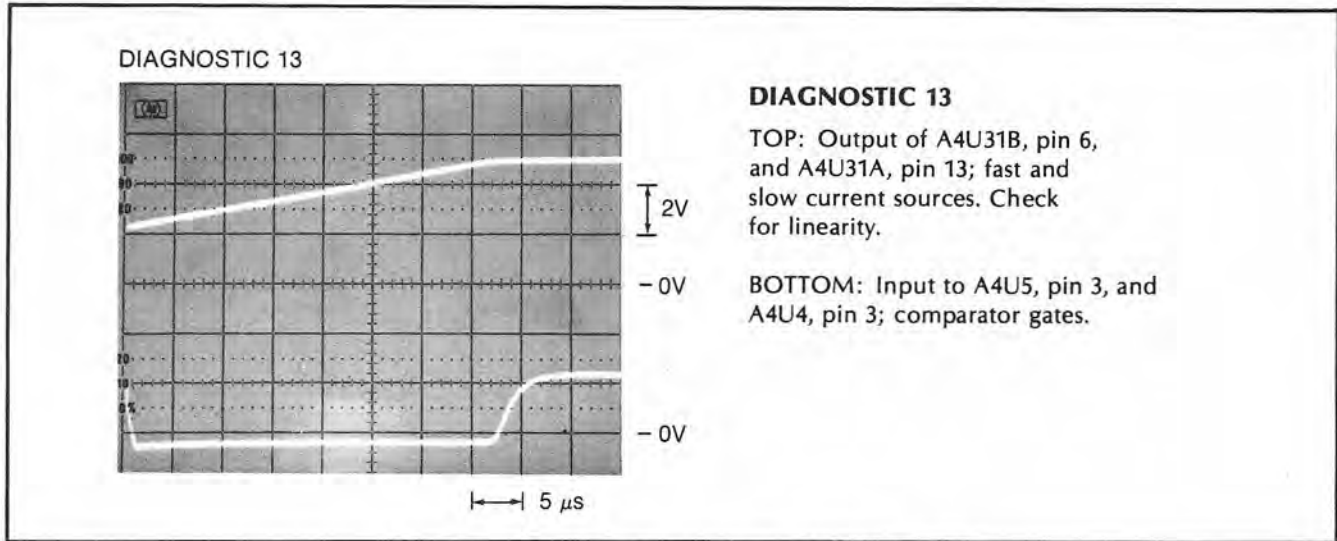

Figure 8-78. Diagnostic 13 Waveform, A4U31 and A4U5

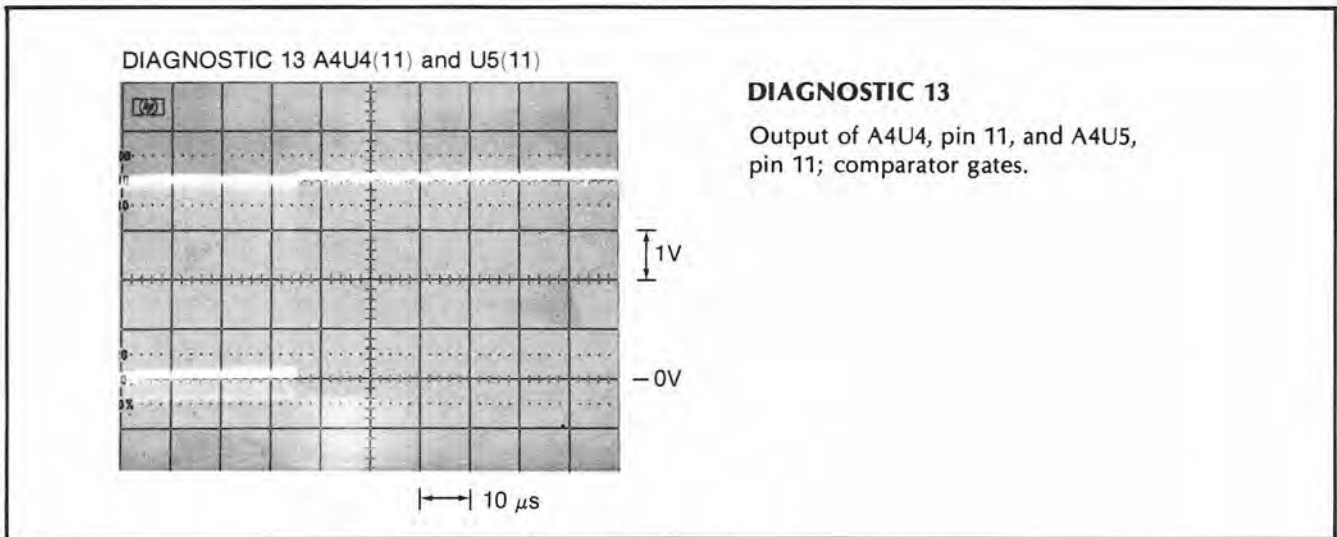

Figure 8-79. Diagnostic 13 Waveform, A4U4 and A4U5

8-423. Time Base Troubleshooting

8-424. There are two oscillators in the A4 assembly: the 10 MHz time base and the 4 MHz processor oscillator; the processor oscillator is divided down to 1 MHz and it is the main enabling signal of the microprocessor system. This 1 MHz signal is the first one to be checked out, as without this signal, the microprocessor system will not operate.

8-425. 4 MHz Microprocessor Oscillator Troubleshooting

a. Verify that the 4 MHz Microprocessor Oscillator signal is present at A4U28(39) and compare with the typical waveform shown in Figure 8-80.

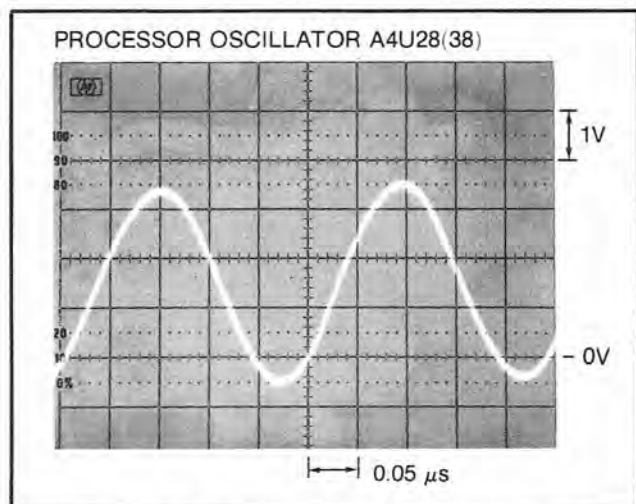

Figure 8-80. 4 MHz Microprocessor Oscillator Signal

b. If the 4 MHz signal is not present at A4U28(39), suspect A4Y2. If the 4 MHz signal is present, verify that the 1 MHz signal at A4U28(37) is present and that it is similar to the waveform in *Figure 8-81*.

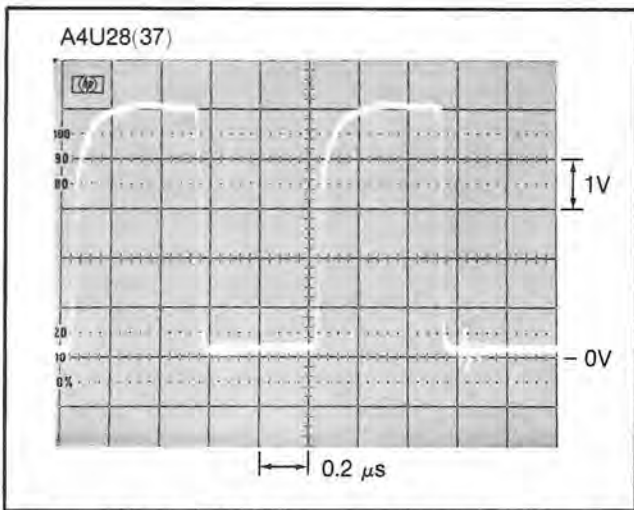

Figure 8-81. 1 MHz Microprocessor Oscillator Signal

c. If the 1 MHz signal is not present at A4U28(37), suspect A4U28.

8-426. 10 MHz Time Base Oscillator Troubleshooting

a. To verify the proper operation of the 10 MHz time base oscillator (Y1) on the Main Logic Assembly (A4), and the associated circuitry, check for the presence of the 10 MHz signal at Test Point marked "CLK" [same as A4U6(21)], and compare with the typical waveform in *Figure 8-82*.

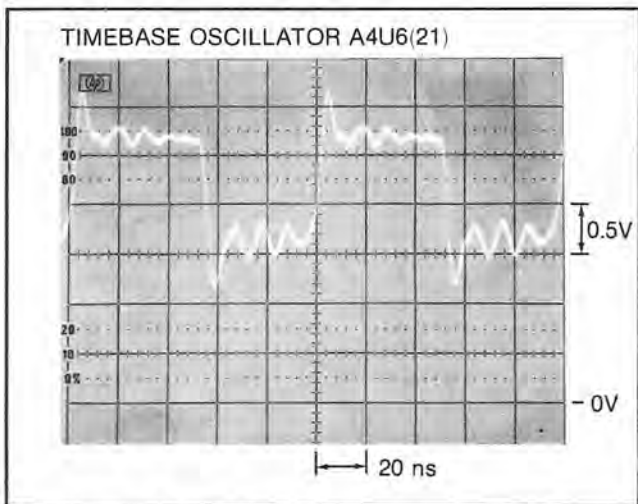

Figure 8-82. 10 MHz Timebase Oscillator Signal

b. If the internal 10 MHz signal is not present at test point "CLK", or A4U6(21), back-trace to determine if the signal is present at A4Y1, A4U2B, and A4U1.

c. If the Option 010 temperature-controlled oscillator is installed, and the 10 MHz signal is not present at test point "CLK" or A4U6(21), check to see if the signal is present at A4U1(6). If the 10 MHz signal is not present at A4U1, check the voltage regulator (A4U29) for +12.15V at pin (1), and +24.5V at pin (3). If the voltages are present at A4U29(1 and 3), suspect the Option 010 oscillator.

8-427. Power-Up Reset Troubleshooting

8-428. The power-up reset circuit, composed of A4CR10, C42, Q12 and Q13, provides a reset pulse to the A4U28 microprocessor of about 140 milliseconds as shown in *Figure 8-83*.

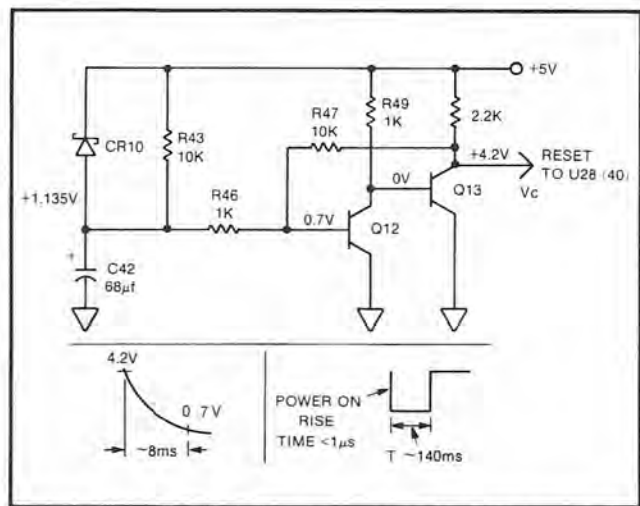

Figure 8-83. Power-Up Reset Circuit Waveform

8-429. A5 AND A10 KEYBOARD AND DISPLAY TROUBLESHOOTING

8-430. The A5 and A10 assemblies are composed of three annunciators and segment drivers (U1, U7 and U2), 14 seven-segment displays (DS1 through DS14), a driver selector U4, data latch U5, a key status buffer U6, a keyboard interrupt U3, and a total of 46 momentary switches (including A10.) The A10 keyboard, which is only installed with Option 040, has 12 momentary pushbutton switches with LED lights. The annunciator-driver, A5U2, powers the A10 LED's.

8-431. Troubleshooting these assemblies is fairly easy with the aid of the A5 block diagram, *Figure 8-84*, and Diagnostic #15. *Table 8-19* lists the A5 connector pins and signal names. Failures on single LED's and seven-segment displays are detected by using the

front panel "CHECK" function or by enabling Diagnostic #15 as follows:

Press: SCALE, SMOOTH 9, 9, ENTER.
Wait about 5 seconds, then press: SCALE, 15, ENTER.

Table 8-19. A5 Keyboard and Display Connector Pins

| A4J3 PIN | A5P2 PIN | DESCRIPTION |
|----------|----------|--------------------------------|
| 1 | 1 | Ground |
| 2 | 2 | N.C. (Connector Key) |
| 3 | 3 | Data Line 5 |
| 4 | 4 | Data Line 7 |
| 5 | 5 | Data Line 4 |
| 6 | 6 | Data Line 6 |
| 7 | 7 | Data Line 0 |
| 8 | 8 | Data Line 3 |
| 9 | 9 | Data Line 1 |
| 10 | 10 | Data Line 2 |
| 11 | 11 | MTN |
| 12 | 12 | Keyboard IRQ |
| 13 | 13 | E2 (Keyboard Display Control) |
| 14 | 14 | E1 (Keyboard Display Data Out) |
| 15 | 15 | E0 (Keyboard Status) |
| 16 | 16 | +5V |

8-432. All LED's and seven-segments will light up and will remain on enabling the technician to visually inspect all annunciators. The seven-segments can be accessed and replaced by just removing the 5335A front panel window.

8-433. Each driver/decoder drives 8 digits. U1 drives the eight left-most digits, U7 drives the six right-most digits plus the HP-IB annunciators and some of the function annunciators; U2 drives the balance of the annunciators plus the Option 040 annunciators. Therefore, look for groups of eight or six bad seven-segment displays or sections of blank LED's. If one group is defective, the trouble is probably in the driver for that group.

8-434. A shorted or open data bus line will affect more than one group of seven-segments or LED's. A loose key spring could bridge across a couple of data lines and be the major cause of shorts. The key caps can be removed with certain amount of difficulty, by pulling the caps out. This will enable the access to the key internal structure.

8-435. If a key pressed does not "access the function", check for pulses going "high" at A5U3(8); then you can trace back to the "stuck" key, back to the output of the A5U5 data latch.

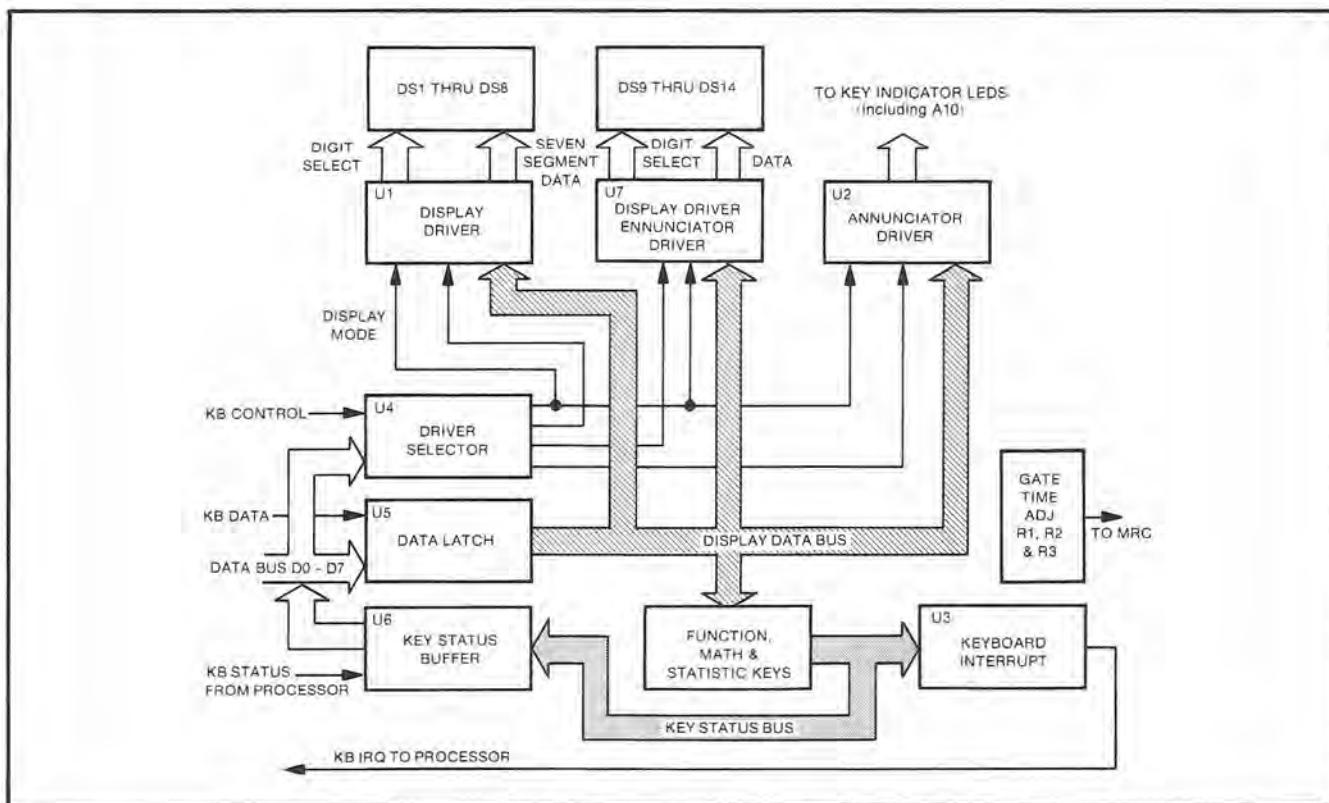

Figure 8-84. A5 Keyboard and Display Block Diagram

8-436. A6 REAR PANEL ASSEMBLY TROUBLESHOOTING

8-437. The A6 Rear Panel assembly is composed basically of four blocks: The GATE OUT level shifter, the External Arm overvoltage protection circuitry, the Time Base Multiplier circuit, and the External Arm switches. The Trigger Level Out signals from the A2/A11 support boards, are fed directly (through A4) to the rear panel BNC connector A6J1 and J4. *Figure 8-85* is the A6 block diagram and *Table 8-20* lists the connector pins and signals.

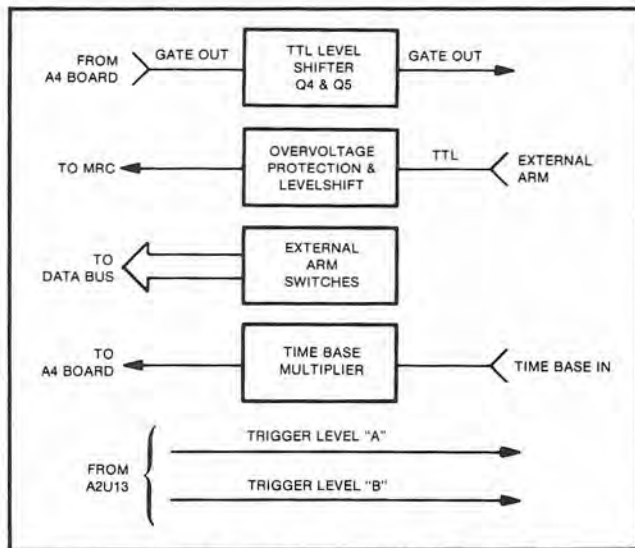

Figure 8-85. A6 Rear Panel Block Diagram

Table 8-20. A6 Rear Panel Board Connector Pins

| A4J1 PIN | A6J7 PIN | DESCRIPTION |
|----------|----------|-------------------------|
| 1 | 1 | +3V |
| 2 | 2 | TLB (Trigger Level B) |
| 3 | 3 | Stop f |
| 4 | 4 | Gate Output |
| 5 | 5 | GND (clean) |
| 6 | 6 | Ext time base in |
| 7 | 7 | Start f |
| 8 | 8 | Osc Out (Time Base Out) |
| 9 | 9 | +5V |
| 10 | 10 | Stop \bar{f} |
| 11 | 11 | Ground (clean) |
| 12 | 12 | Start \bar{f} |
| 13 | 13 | Ground (clean) |
| 14 | 14 | -5.2V |
| 15 | 15 | TLA (Trigger Level A) |
| 16 | 16 | Ext Arm (to MRC) |

8-438. GATE OUT Circuitry Troubleshooting

8-439. The GATE OUT circuitry is a level shifter and an amplifier that can drive TTL loads as well as 50 ohm loads. To troubleshoot this circuitry, enable the GATE TIME function on the 5335A, and set the gate time to about 20 milliseconds at NORMAL cycle. Verify that the waveforms in *Figures 8-86* through *8-89* are obtained at the specified points.

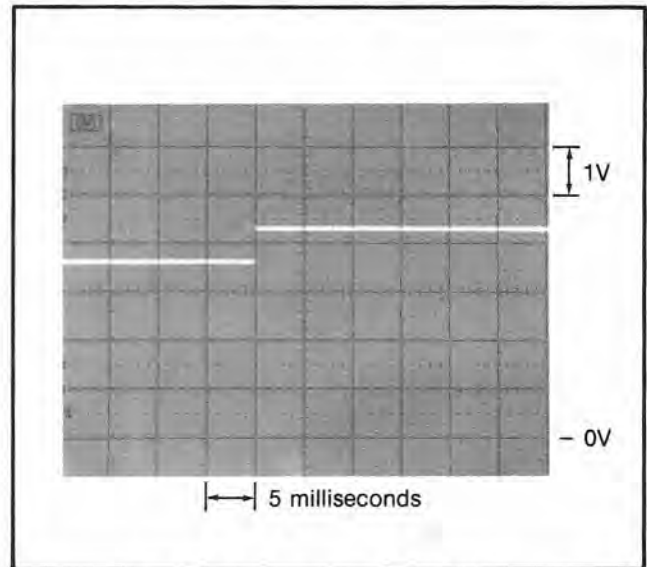

Figure 8-86. Waveform at A6Q4 Base

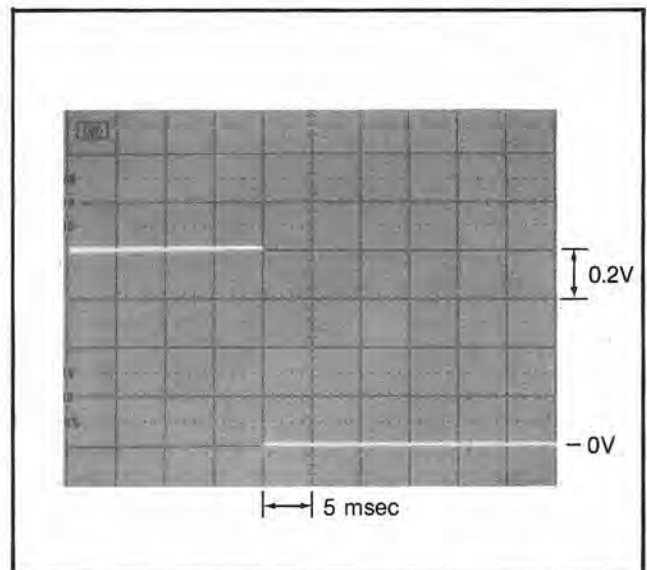

Figure 8-87. Waveform at A6Q5 Base

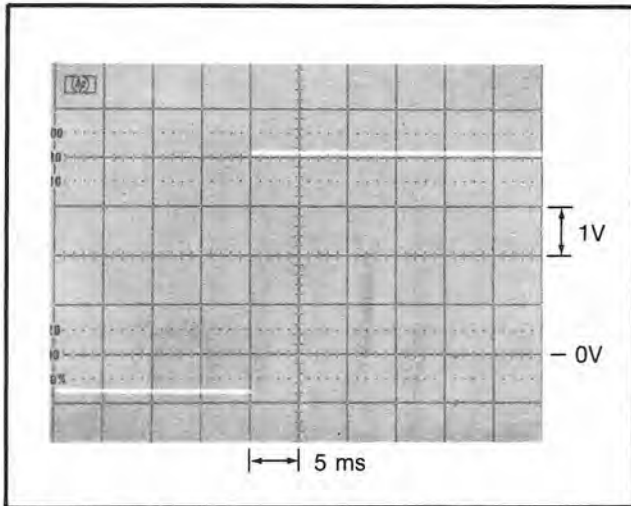

Figure 8-88. Waveform at A6Q5 Collector (Into 1Ω)

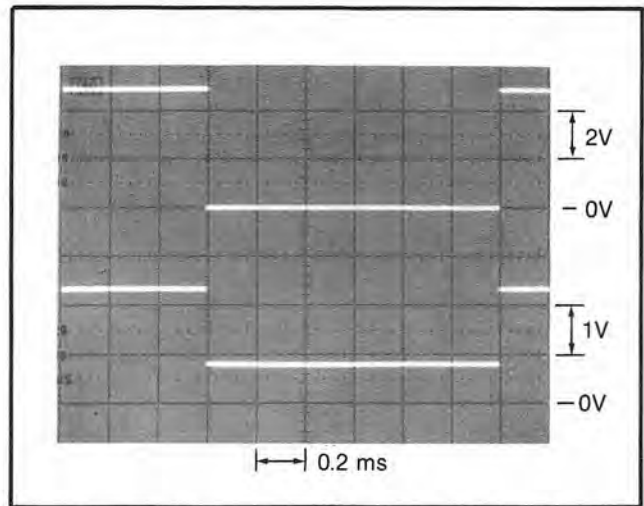

Figure 8-90. A6 External Arm Test Waveforms

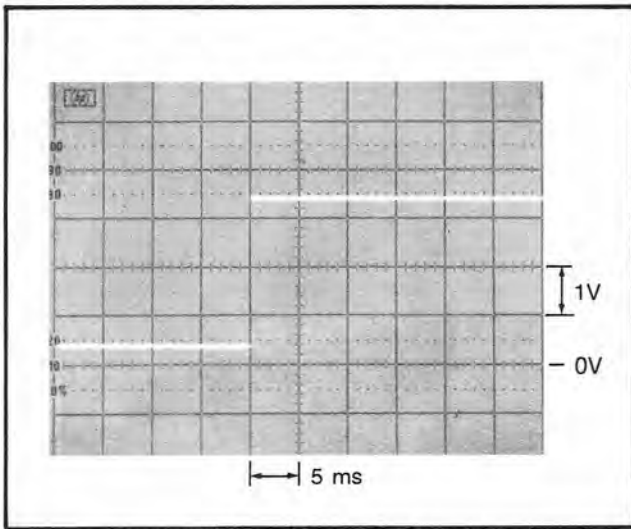

Figure 8-89. Waveform at A6Q5 Collector (Into 50Ω)

8-440. External Arm Input Circuitry Troubleshooting

8-441. The External Arm input circuitry is a differential pair (A6Q1 and Q2) with overvoltage protection; A6CR1 protects against negative voltages (<0V), and A6Q1 protects against voltages >5 volts. To troubleshoot this circuitry, apply a TTL type signal to the External Arm Input similar to the one shown in the top portion of Figure 8-90; insure that the EXTERNAL ARM ADJUST pot is in the cw position (TTL). The bottom portion of the figure is the resulting signal that goes into the A4U6(17).

8-442. Time Base Multiplier Troubleshooting

8-443. The external time base input circuitry is a three-stage tank filter, set at 10 MHz, with clipping diodes to help produce harmonics to the tanks. The tank components have a 1% tolerance, and therefore do not need adjustments. The ECL output level is fed to an ECL receiver on the A4 Main board (A4U2A).

$$\text{Resonant Frequency} = \frac{1}{2\pi\sqrt{LC}} = 10 \text{ MHz}$$

(L = 1 μH, C = 250 pF)

8-444. To troubleshoot the A6 time base multiplier, apply a 5 MHz signal at about 350 mV peak-to-peak to the 5335A rear panel TIME BASE IN connector. Figure 8-91 shows a typical satisfactory waveform.

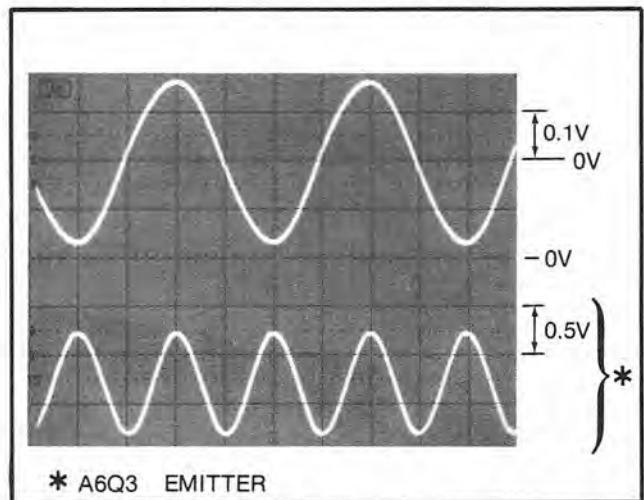

Figure 8-91. A6 Timebase Multiplier Test Waveforms

8-445. EXTERNAL ARM Switches Troubleshooting

8-446. The EXTERNAL ARM switches indicate to the processor which edge of either START or STOP of the external arming signal is to be selected, when the EXT ARM ENABLE function switch on the 5335A front panel has been selected. Table 8-21 indicates the state of data line as a function of the arming switches:

Table 8-21. External Arm Data Lines States

| START | STOP | START \overline{f} A6R5(3) | START $\overline{\bar{f}}$ A6R5(5) | STOP \overline{f} A6R5(4) | STOP $\overline{\bar{f}}$ A6R5(6) |
|----------------------|----------------------|---------------------------------|---------------------------------------|--------------------------------|--------------------------------------|
| OFF | OFF | 1 | 1 | 1 | 1 |
| \overline{f} | \overline{f} | 0 | 1 | 0 | 1 |
| $\overline{\bar{f}}$ | $\overline{\bar{f}}$ | 1 | 0 | 1 | 0 |

This data goes into A4U15 in the A4 Main Logic Board.

8-447. A7 HP-IB ASSEMBLY TROUBLESHOOTING

8-448. The HP-IB Interface Logic Assembly serves as an interface between the 5335A and an external controller, via the Hewlett-Packard Interface Bus. The circuitry includes bus buffers (A7U3, U4, U6, U7), decoding ROMS and an LSI HP-IB Interface IC (A7U1). These circuits perform the handshake and interpret commands, data, interrupts, etc. Refer to Figure 8-92 A7 Block Diagram and Tables 8-22, 8-23 and 8-24.

Table 8-22. HP-IB Assembly Pin Connections (A4/A7)

| A4XA7 Pin | A7P1 Pin | Description | A4XA7 Pin | A7P1 Pin | Description |
|-----------|----------|--------------------------|-----------------|-----------------|---------------------------|
| 1 | 1 | A1 | $\overline{1}$ | $\overline{1}$ | A2 |
| 2 | 2 | A3 | $\overline{2}$ | $\overline{2}$ | A2 |
| 3 | 3 | A5 | $\overline{3}$ | $\overline{3}$ | A4 |
| 4 | 4 | A7 | $\overline{4}$ | $\overline{4}$ | A6 |
| 5 | 5 | A9 | $\overline{5}$ | $\overline{5}$ | A8 |
| 6 | 6 | A11 | $\overline{6}$ | $\overline{6}$ | A10 |
| 7 | 7 | A13 | $\overline{7}$ | $\overline{7}$ | A12 |
| 8 | 8 | Reset | $\overline{8}$ | $\overline{8}$ | A14 |
| 9 | 9 | E(1MHz) | $\overline{9}$ | $\overline{9}$ | $\overline{\text{NMI}}$ |
| 10 | 10 | $\overline{\text{IRQ}}$ | $\overline{10}$ | $\overline{10}$ | RAM ENABLE |
| 11 | 11 | VMA | $\overline{11}$ | $\overline{11}$ | $\overline{\text{VMA.E}}$ |
| 12 | 12 | R/ $\overline{\text{W}}$ | $\overline{12}$ | $\overline{12}$ | A15 |
| 13 | 13 | Ground | $\overline{13}$ | $\overline{13}$ | Ground |
| 14 | 14 | +5V | $\overline{14}$ | $\overline{14}$ | -5.2 V |
| 15 | 15 | D1 | $\overline{15}$ | $\overline{15}$ | D0 |
| 16 | 16 | D3 | $\overline{16}$ | $\overline{16}$ | D2 |
| 17 | 17 | D5 | $\overline{17}$ | $\overline{17}$ | D4 |
| 18 | 18 | D7 | $\overline{18}$ | $\overline{18}$ | D6 |

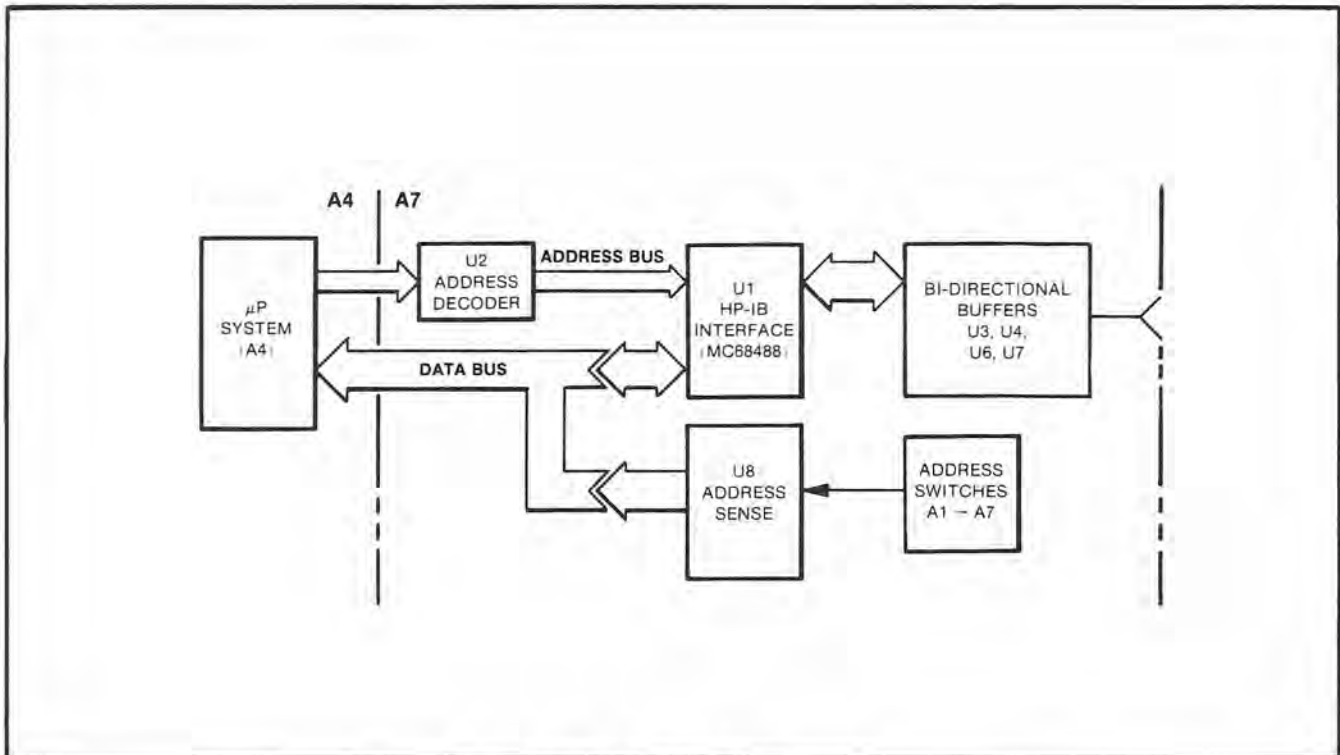

Figure 8-92. A7 HP-IB Block Diagram

Table 8-23. HP-IB Assembly Pin Connections (A7/A14)

| A7J1 Pin | A14J1 Pin | Description | A7J1 Pin | A14J2 Pin | Description |
|----------|-----------|-------------|----------|-----------|-------------|
| 1 | 1 | EO1 | 1 | 1 | Ground |
| 2 | 2 | DAV | 2 | 2 | A1 |
| 3 | 3 | RFD | 3 | 3 | A2 |
| 4 | 4 | DAC | 3 | 3 | A3 |
| 5 | 5 | IFC | 3 | 3 | DIO1 |
| 6 | 6 | SRQ | 6 | 6 | DIO2 |
| 7 | 7 | ATN | 7 | 7 | DIO3 |
| 8 | 8 | N.C. | 8 | 8 | DIO4 |
| 9 | 9 | Ground | 9 | 9 | DIO8 |
| 10 | 10 | Ground | 10 | 10 | DIO7 |
| 11 | 11 | Ground | 11 | 11 | DIO6 |
| 12 | 12 | Ground | 12 | 12 | DIO5 |
| 13 | 13 | Ground | 13 | 13 | A7 (Talk) |
| 14 | 14 | Ground | 14 | 14 | A6 (Listen) |
| 15 | 15 | Ground | 15 | 15 | A5 |
| 16 | 16 | REN | 16 | 16 | A4 |

Table 8-24. HP-IB Interface Connector Signals

| HP-IB Pin | Connectors Signals |
|-----------|------------------------------|
| 1 | DIO1 |
| 2 | DIO2 |
| 3 | DIO3 |
| 4 | DIO4 |
| 5 | EOI |
| 6 | DAV |
| 7 | NRFD |
| 8 | NDAC |
| 9 | IFC |
| 10 | SRQ |
| 11 | ATN |
| 12 | SHIELD CHASSIS GROUND |
| 13 | DIO5 |
| 14 | DIO6 |
| 15 | DIO7 |
| 16 | DIO8 |
| 17 | REN |
| 18 | P/O Twisted Pair with Pin 6 |
| 19 | P/O Twisted Pair with Pin 7 |
| 20 | P/O Twisted Pair with Pin 8 |
| 21 | P/O Twisted pair with Pin 9 |
| 22 | P/O Twisted Pair with Pin 10 |
| 23 | P/O Twisted Pair with Pin 11 |
| 24 | ISOLATED DIGITAL GROUND |

8-449. To troubleshoot the A7 assembly, setup the counter (microprocessor system) for signature analysis in its FREERUN mode. Setup:

a. Connect the Signature Analyzer START, STOP, and CLOCK pod leads to corresponding test pins next to the A4U28 microprocessor. Ensure that the CLOCK test lead is connected to the test pin marked "CK1".

b. Set the START, STOP, and CLOCK switches on the Signature Analyzer to the negative edge (\neg).

c. Connect a jumper between the test pins marked "SA" and "G", located between A4U12 and A4U21. This will set the microprocessor in its "FREERUN" mode.

d. Set the 5335A power switch from STBY to ON. The 5335A display should be blank with the only possible exception of the Channel A and B trigger lights. Verify the characteristics power supply signature as being: 0003; if this signature is correct, it signifies proper connection of the Signature Analyzer.

e. Verify the signatures at the following key test points:

| TEST POINT | SIGNATURE |
|------------|-----------|
| A7U2(1,11) | 7APA |
| A7U2(2) | 6U28 |
| A7U2(3) | 4FCA |
| A7U2(5) | U867 |
| A7U2(13) | 9UP1 |
| A7U2(14) | 4868 |
| A7U1(4) | P546 |

f. If any of these "key test point" signatures are not correct, proceed to back-trace the signatures into the A4 Main Logic board. Refer to paragraph 8-404 to check out the microprocessor system and associated hardware key signature, and to paragraph 8-409 to verify proper operation with the ROMs.

g. If signatures are correct, proceed to paragraph 8-410, which provides the procedure to check out the microprocessor system output ports, with the 5335A setup in its "STIMULUS MODE".

8-450. A8 DIGITAL VOLTMETER TROUBLESHOOTING

8-451. The A8 Digital DC Voltmeter assembly contains the Input/Amplifier buffer U11 with selectable gain feedback paths (Q4, Q5 and Q6), the reference (U4, U5), voltage multiplexer (U7), the voltage-to-frequency converter (U6 and U8), the input switching control (U3, U9, U10, U12, U13, Q2, Q3, Q7), and the power supply (T1, CR1, U1). Refer to the A8 block diagram (Figure 8-93) and the A8 schematic diagram to troubleshoot this assembly. Table 8-25 lists the connector functions.

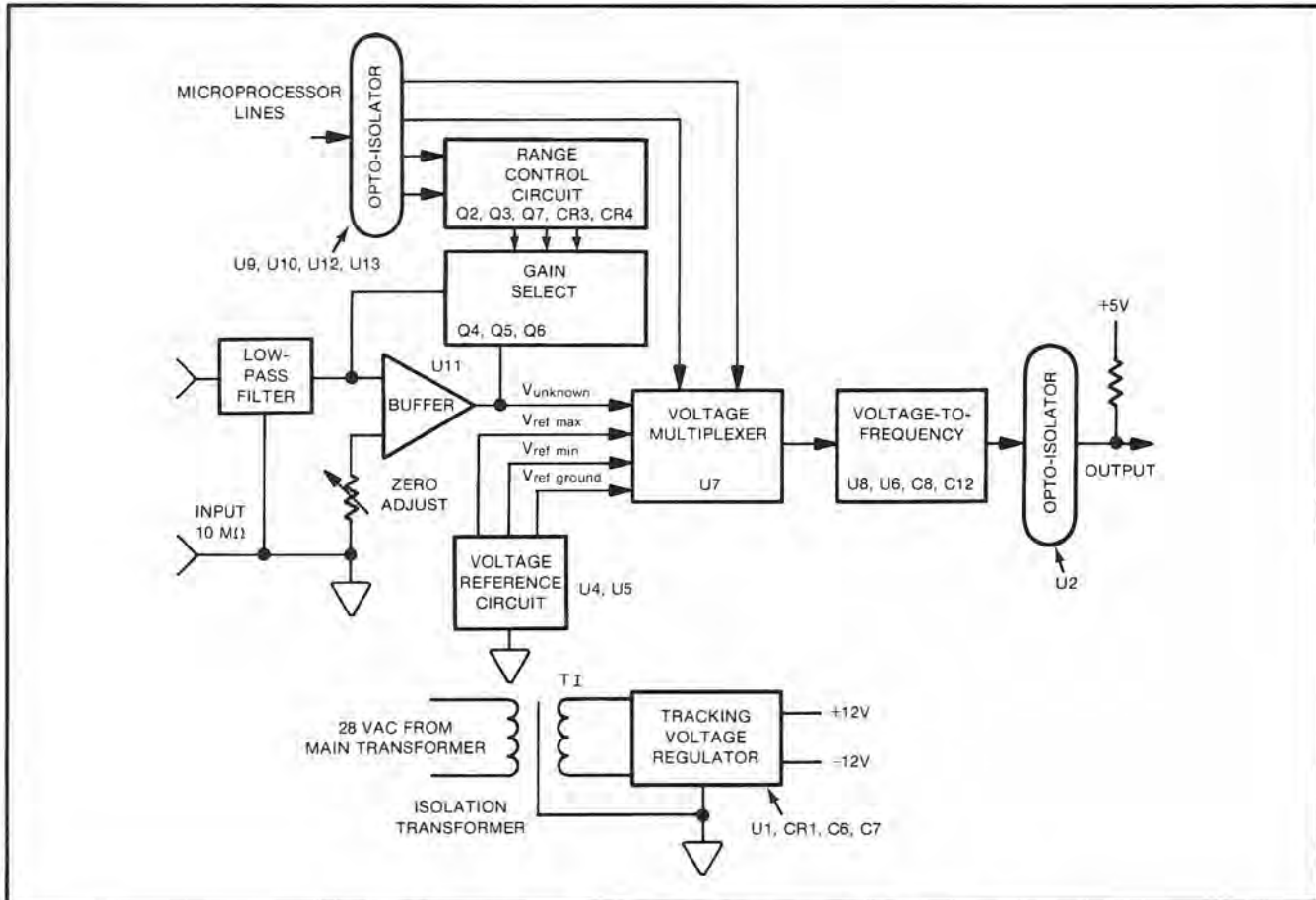

Figure 8-93. A8 Digital Voltmeter (Option 020) Block Diagram

Table 8-25. A8 Connector Pin Functions

| A2XA8 Pin | A8P1 Pin | Description |
|-----------|----------|-----------------------|
| 1 | 1 | Ground |
| 2 | 2 | AC Supply (18.5V rms) |
| 3 | 3 | Enable |
| 4 | 4 | +5 VOLTS |
| 5 | 5 | Ground (Option IN) |
| 6 | 6 | Ground |
| 1̄ | 1̄ | DVM Output (Freq) |
| 2̄ | 2̄ | AC Supply (18.5V rms) |
| 3̄ | 3̄ | Data Line 5 |
| 4̄ | 4̄ | Data Line 6 |
| 5̄ | 5̄ | Data Line 7 |
| 6̄ | 6̄ | Data Line 4 |

| DIAGNOSTIC | DESCRIPTION |
|------------|---|
| #20) DVM | Mux — -5V Ref (Freq Out ~ 800 Hz) |
| #21) DVM | Mux — Gnd Ref (Freq Out ~ 6 KHz) |
| #22) DVM | Mux — +5V Ref (Freq Out ~ 11 KHz) |
| #23) INPUT | VOLTAGE RANGE SELECT (LOW) 10V RANGE SELECT (Min Freq ~ 150Hz) |
| #24) INPUT | VOLTAGE RANGE SELECT (MID) 100V RANGE SELECT |
| #25) INPUT | VOLTAGE RANGE SELECT (HIGH) 1000V RANGE SELECT |

8-452. There are six software diagnostic subroutines to help in the troubleshooting of the Option 020 assembly. They are:

8-453. To access anyone of the diagnostics listed above, follow these procedures:

- Press: SCALE, SMOOTH, 9, 9, ENTER; wait 5 seconds, (enables diagnostic mode).
- Press: SCALE, 2, 0, through 2,5, ENTER.

NOTE

Set "RANGE HOLD" **ON** when using these diagnostic subroutines for stable output frequencies at A1TP3 "FREQ OUT".

8-454. Diagnostic Subroutines #20, #21, #22 are designed to set up the DVM option to measure and display the voltage and frequency of the -5V, GND, +5V references. These routines verify all the A8 DVM circuitry with the exception of the Range Select circuits (A8U11, U12, U13).

8-455. Diagnostic Subroutines #23, #24, #25 force the DVM option into its LOW, MED, and HIGH range, respectively. By inputting a known dc voltage to the DVM input, the input amplifier A8U11, the FETs and transistors, which select the different ranges can be tested. The autorange feature of the DVM is disabled in these tests.

8-456. Input Amplifier and Range Control Troubleshooting

8-457. U11 is the Input amplifier buffer with selectable gain feedback loops. There are three feedback resistor loops, selectable by the microprocessor via Q4, Q6, and Q5 FETs. These loops set up gains of -1/2 (Low) -1/20 (Medium), and -1/200 (High), respectively, with one loop selected at the time; they are selected so that U11(6) output volts is within ±5 volts. Table 8-26 lists Q4, Q5, and Q6 states for diagnostics #23, #24, and #25.

Table 8-26. A8Q4, Q5, and Q6 States in Diagnostics #23, #24, and #25

| DIAG # | RANGE SELECT | | |
|---------------------------------|--------------|--------------|-----------|
| | HIGH Q5(G) | MEDIUM Q6(G) | LOW Q4(G) |
| 23 | OFF | OFF | ON |
| 24 | OFF | ON | OFF |
| 25 | ON | OFF | OFF |
| ON = 0 volts OFF = -12 volts | | | |

8-458. To troubleshoot feedback loops, apply a 4-volt dc level to the Option 020 DVM input. With a DVM, monitor the voltage at TP1, as diagnostic #23, #24 and #25 is selected. Table 8-27 lists the correct voltages at TP1.

Table 8-27. A8TP1 Voltages for Diagnostics #23, #24, and #25

| DVM INPUT VOLTAGE | VOLTAGE AT TP1 | | |
|-------------------|----------------|----------|----------|
| | DIAG #23 | DIAG #24 | DIAG #25 |
| +4V | -2V | -0.2V | -0.02V |
| -4V | +2V | +0.2V | +0.02V |

8-459. Reference and Voltage Multiplexer Troubleshooting

8-460. A8U4 and A8U5 provide the +5V, Ground, and -5V references to the input of A8U7 multiplexer. The microprocessor utilizes these three voltage references to compute the unknown input voltage. The U7 control bits originate in U9 and U10 optic-isolators. See Table 8-28.

Table 8-28. A8U7 States in Diagnostics #20-#25

| DIAG # | A8U7 | | TP2 | TP3 |
|------------|--------|-------|--------|--------|
| | Pin 16 | Pin 1 | | |
| 20 | 0 | 0 | -5V | ~800Hz |
| 21 | 0 | 1 | 0V | ~6KHz |
| 22 | 1 | 0 | +5V | ~11KHz |
| 23, 24, 25 | 1 | 1 | Vinput | |

8-461. Voltage-to-Frequency Converter Troubleshooting

8-462. The voltage-to-frequency converter circuit is composed of A8U6 V-to-F, U8 unity gain buffer, C12 the integrating capacitor, C8 the one-shot capacitor, and U2 optic-isolator (converts the floating frequency output to a chassis-referenced output). Use Table 8-29 to troubleshoot this section.

NOTE

A8U6(1) voltage is always equal to **zero**.

Table 8-29. A8 Voltage-to-Frequency Conversion

| INPUT VOLTAGE (V) | OUTPUT FREQUENCY (Hz) |
|-------------------|-----------------------|
| +10 | 800 |
| +9 | 1.31K |
| +8 | 1.82K |
| +7 | 2.33K |
| +6 | 2.84K |
| +5 | 3.35K |
| +4 | 3.86K |
| +3 | 4.36K |
| +2 | 4.87K |
| +1 | 5.38K |
| 0 | 5.89K |
| -1 | 6.40K |
| -2 | 6.91K |
| -3 | 7.42K |
| -4 | 7.93K |
| -5 | 8.43K |
| -6 | 8.94K |
| -7 | 9.45K |
| -8 | 9.96K |
| -9 | 10.47K |
| -10 | 10.98K |

NOTE: The output frequency will vary slightly from instrument to instrument. The above table is for information **ONLY**, and gives only an approximation of the voltage-to-frequency relationship.

8-463. Input Logic Switching Control Troubleshooting

8-464. The Input Logic Switching Control circuitry consists of A8U3 register, that latches four bits from the microprocessor controlled data bus, U9, U10, U12, U13 optic-isolators, and A8Q2, Q3, and Q7, which decodes and provides range selection information, as well as control bits for U7, the reference multiplexer.

8-465. To troubleshoot this section, check the dc levels of the circuit per *Table 8-30*.

8-466. Power Supply Troubleshooting

8-467. Transformer T1 (1:1 ratio), full wave rectifier CR1, and U1 dual-tracking regulator, form the floating power supply of A8.

8-468. A9 CHANNEL C (OPTION 030) TROUBLESHOOTING

8-469. The A9 Channel C assembly contains the Overload/Limiter/Pin Diode Attenuator circuits, the U1 Amplifier, a level detector (CR5, CR14), a U2 Decade, and U3 Binary divider blocks. Refer to the A9 block diagram (*Figure 8-94*) to troubleshoot the Option 030 C Channel.

8-470. To troubleshoot the A9 assembly, first refer to Section III to check for an open input fuse. If the fuse is open replace the fuse.

8-471. If fuse is good, and all power supplies are present (+5V, -5.2V, and +15.7V), then the next thing to check is the self oscillating frequency, use the following procedure:

- Set **L** pot to the clockwise position.
- Connect a jumper between -5.2V and TP2.
- Enable **FREQ C**; 5335A should display: 1.0 GHz \pm 60 MHz.
- Vary the **H** pot and check for a variation in the display of about 500 MHz. If no response, check signal through Q1.

8-472. If self oscillation frequency is not OK, then set the self oscillating frequency per procedure in Section V.

8-473. Apply a 150 MHz signal at 400 mV p-p to INPUT C, with the 5335A Channel C function enabled. Set GATE TIME to about 200 milliseconds. Refer to the A9 schematic diagram and check that the proper waveform exists at the indicated points. *Figure 8-95* shows A9 test point waveforms.

Table 8-30. A8 Input Logic Switching Troubleshooting

| | DIAGNOSTIC | | | | | |
|-------------------|------------|------------|------------|------|------|-------|
| | #20 | #21 | #22 | #23 | #24 | #25 |
| U3 PIN 2) | LO | LO | LO | HI | HI | LO |
| 7) | LO | LO | LO | HI | LO | HI |
| 10) | LO | LO | HI | HI | HI | HI |
| 15) | LO | HI | LO | HI | HI | HI |
| U9-5) | 0V | 0V | +12V | +12V | +12V | +12V |
| U10-5) | 0V | +12V | 0V | +12V | +12V | +12V |
| U12-5) | -12V | -12V | -12V | 0V | 0V | -12V |
| U13-5) | -12V | -12V | -12V | 0V | -12V | 0V |
| Q7 Collector C-Q2 | -12V | -12V | -12V | 0V | -12V | -12V |
| Q7 Collector C-Q3 | 0V | 0V | 0V | -12V | -12V | 0V |
| Q7 Collector C-Q7 | 0V | 0V | 0V | -12V | 0V | -12V |
| Voltage Select | -5V Ref | Gnd Ref | +5 Ref | Vin | Vin | Vin |
| Range Select | Don't Care | Don't Care | Don't Care | X10 | X100 | X1000 |

NOTE: When collector of Q3, Q2, Q7 is low (0V), it will turn on their respect FET, only one range is on at any one time. (Except when Diagnostics #20, #21, and #22 are accessed.)

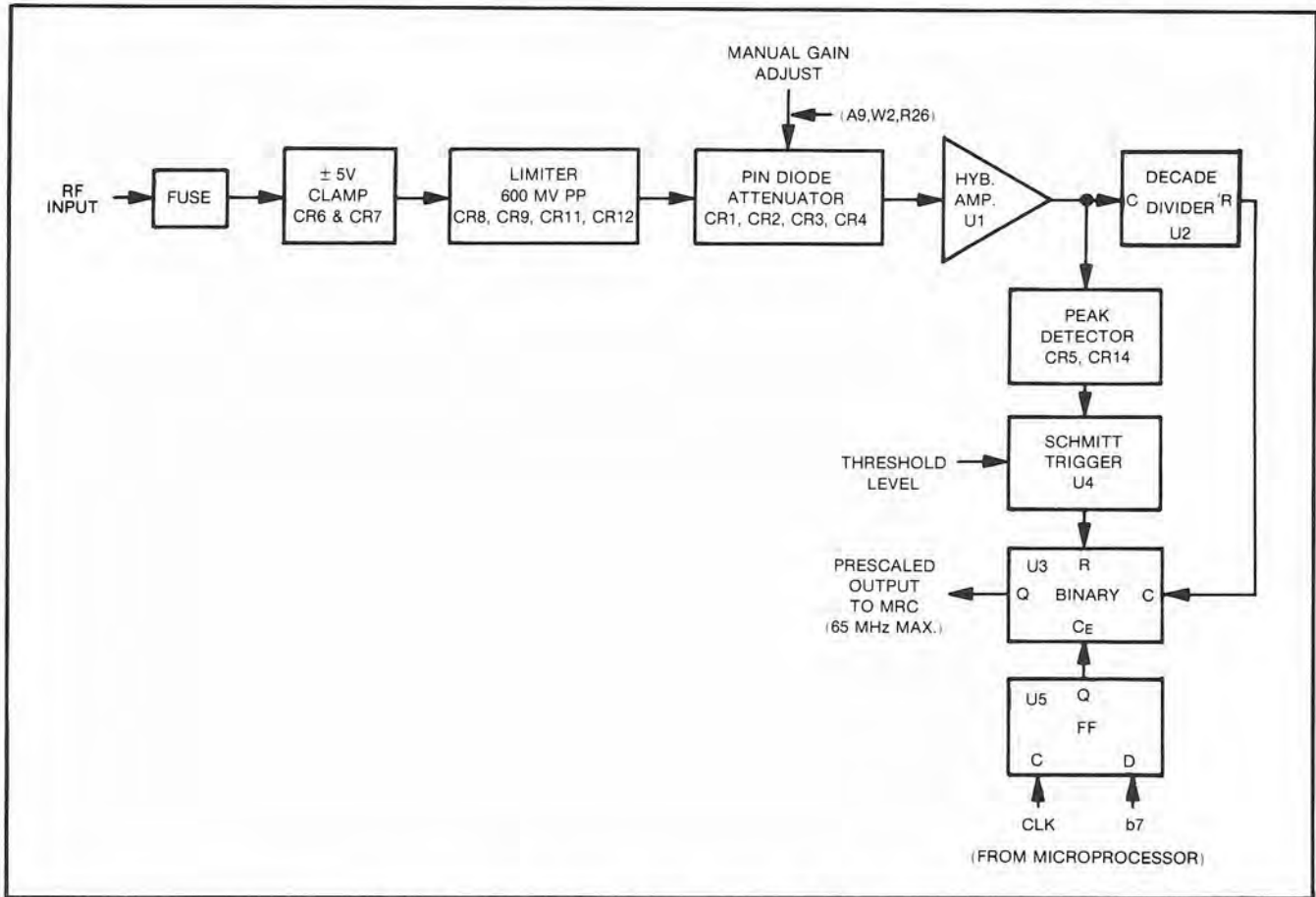

Figure 8-94. A9 Channel C (Option 030) Block Diagram

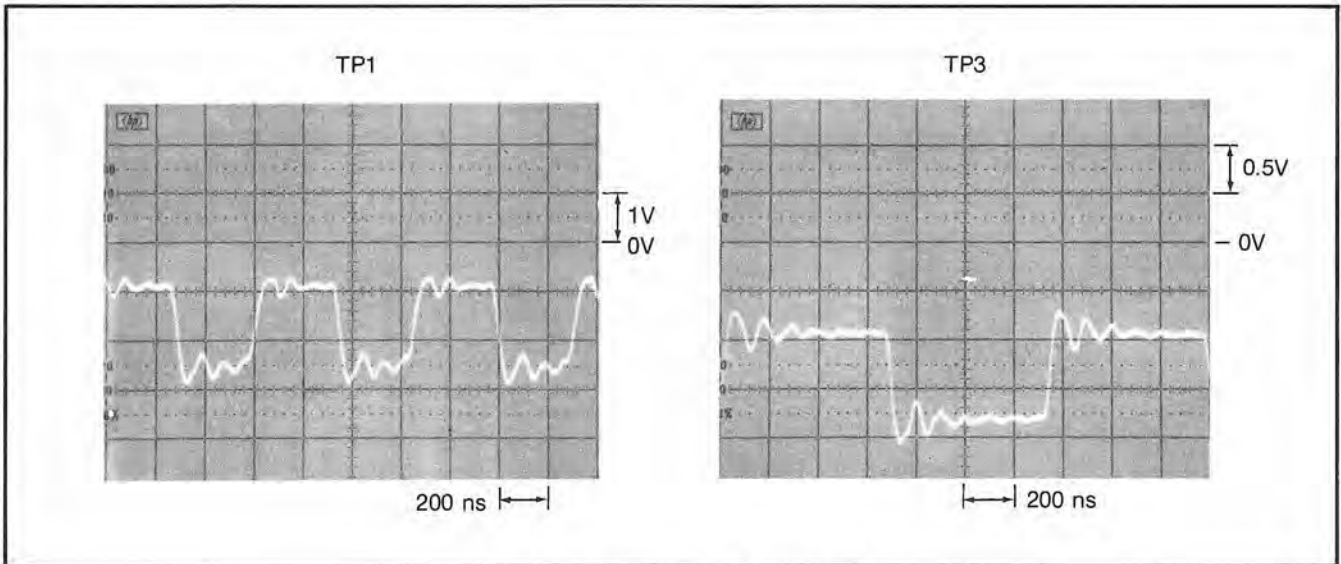

Figure 8-95. A9 Waveforms at TP1 and TP3

8-474. A11 AMPLIFIER SUPPORT TROUBLESHOOTING

8-475. The A11 Amplifier Support Assembly contains the Channel A and B Trigger Level selector, the Digital-to-Analog Converters (DACs), the Trigger Level Voltmeter, the Signal Selector Multiplexer, and the Front End latch control circuitry. The Trigger Level Selector and the Front End latch control circuits complements the peak detector operation in the A12 Programmable Input Buffer assembly.

8-476. Trigger Level Selector Troubleshooting

8-477. Channel A Trigger Level Selector Multiplexer (A11U2) selects among the different input signals (Channel A trigger level pot, the 10%, 50%, and 90% of peak of signal, ground, and -5.2V), a trigger level that is fed back to the A12 assembly. This multiplexer is controlled by the microprocessor, by way of A11U14 and A11U15. Table 8-31 lists the A11U2 control bits.

NOTE

“RANGE HOLD” must be **ON** during this test.

Table 8-31. A11U2 Analog Multiplexer Control Bits

| C1 U2(15) | C12 U2(16) | C11 U2(1) | FUNCTION |
|-----------|------------|-----------|-----------------------------|
| 0 | 0 | 0 | Freq A, Manual Trigger Adj |
| 0 | 0 | 1 | DACs (Diagnostic #34) |
| 0 | 1 | 0 | Freq A, Manual Trig Preset |
| 0 | 1 | 1 | Diag #33 (-5.2V) |
| 1 | 0 | 0 | Freq A, Auto Adjust |
| 1 | 0 | 1 | SLEW Rate A, $\sqrt{\quad}$ |
| 1 | 1 | 0 | Freq A, Auto Preset |
| 1 | 1 | 1 | SLEW Rate A, \backslash |

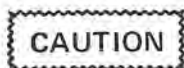

The assemblies and components involved in the following steps are all static sensitive, and should be handled at a static free work area, and in accordance with approved procedures.

8-478. If A11U2 bits are not set properly, check the Front End latch controls A11U15 and U14, by enabling Diagnostics #3 and #4.

8-479. Front End Latch Control Troubleshooting

8-480. Diagnostics #3 and #4 are designed to aid in the troubleshooting of A11U15 and U14, and related circuitry, including A12K1 through K9.

8-481. To enable Diagnostic #3, press: SCALE, SMOOTH, 9, 9, ENTER; wait 5 seconds, then press: SCALE, 3, ENTER. The 5335A will display: “DIAG 03”.

8-482. Diagnostic #3 sets the A11U15 and A11U14 latches output to a TTL “LOW”. With a logic probe oscilloscope, or a voltmeter, verify the state of the latches output per Table 8-32.

Table 8-32. Troubleshooting A11U14 and A11U15

| REF. DESIG. | PIN # | NOMEN. | DIAG. #3 | DIAG. #4 |
|-------------|-------|--------|----------|----------|
| A11U15 | 1 | +5V | | |
| | 2 | C1 | Low | High |
| | 3 | D0 | 1.45V | 1.45V |
| | 4 | D1 | 1.45V | 1.45V |
| | 5 | C2 | Low | High |
| | 6 | D2 | 1.45V | 1.45V |
| | 7 | C3 | Low | High |
| | 8 | GND | | |
| | 9 | *U697 | 4.5V | 4.5V |
| | 10 | C4 | Low | High |
| | 11 | D3 | 1.45V | 1.45V |
| | 12 | C5 | Low | High |
| | 13 | D6 | 1.45V | 1.45V |
| | 14 | D7 | 5.0V | 5.0V |
| | 15 | C6 | Low | High |
| | 16 | +5V | | |
| A11U14 | 1 | +5V | | |
| | 2 | C7 | Low | High |
| | 3 | D0 | 1.45V | 1.45V |
| | 4 | D1 | 1.45V | 1.45V |
| | 5 | C8 | Low | High |
| | 6 | D2 | 1.45V | 1.45V |
| | 7 | C9 | Low | High |
| | 8 | GND | | |
| | 9 | *HA50 | 4.5V | 4.5V |
| | 10 | C10 | Low | High |
| | 11 | D3 | 1.45V | 1.45V |
| | 12 | C11 | Low | High |
| | 13 | D4 | 1.45V | 1.45V |
| | 14 | D5 | 1.45V | 1.45V |
| | 15 | C12 | Low | High |
| | 16 | +5V | | |

* = FREERUN Signature [START, STOP, CLOCK (CK1)]

8-483. To enable Diagnostic #4, press: SCALE, 4, ENTER. This diagnostic sets the latches output to a TTL “HIGH”; verify their state per Table 8-32.

8-484. Troubleshooting the A11U5 Multiplexer

8-485. A11U5 plays a combined role with A11U2 (channel A trigger level selector), and A11U11 (channel B trigger level selector), to select the Trigger Level for the appropriate channel.

8-486. To troubleshoot A11U5, verify the control signal status, by enabling and disabling the AUTO TRIG in FREQ A, and by enabling diagnostic #34. Table 8-33 lists the control signals for A11U5.

Table 8-33. A11U5 Control Signals

| CHANNEL A&B TRIGGER LEVELS (ATL and BTL) | U5(1) | U5(16) |
|--|-------|--------|
| Manual Trigger | 0 | 0 |
| Auto Trigger | 1 | 1 |
| DAC's | 1 | 0 |

8-487. To enable diagnostic #34, press: SCALE, SMOOTH, 9, 9, ENTER. Wait 5 seconds, then press: SCALE, 3, 4, ENTER. The 5335A display will show: "DIAG 34".

8-488. Troubleshooting the Relay Drivers

8-489. To check out the relay drivers A11Q1 through Q9, exit diagnostic mode by pressing FREQ A. Verify the collector voltages in Table 8-34, and the outputs of A11U18, by enabling and disabling the corresponding input conditioning controls:

Table 8-34. A11 Relay Driver Collector Voltages

| Relay Driver | Description | Voltages | A11U18 |
|--------------|--------------------|----------|---------------------|
| Q1 | CH B 50Ω/1 MΩ | -12V/0V | Pin #2: 0.280V/5V |
| Q2 | CH B AC/DC | -12V/0V | Pin #5: 0.280V/5V |
| Q3 | CH B Filter ON/OFF | -12V/0V | Pin #6: 0.280V/5V |
| Q4 | CH B Attenuator | -12V/0V | Pin #9: 0.280V/5V |
| Q5 | CH A 50Ω/1 MΩ | -12V/0V | Pin #12: 0.280V/5V |
| Q6 | CH A Filter ON/OFF | -12V/0V | Pin #15: 0.280V/5V |
| Q8 | CH A AC/DC | -12V/0V | Pin #16: 0.280V/5V |
| Q9 | CH A Attenuator | -12V/0V | Pin #19: 0.28V/5V |
| Q7 | COM A/Separate | 0V/-12V | U15(5): 0.170V/4.5V |

8-490. Digital-to-Analog Converter Troubleshooting

8-491. The Digital-to-Analog Converter (DAC's) circuitry is composed of A11U23 (Channel A), U21 (Channel B), both 10-bit D/A ICs, U16, U17, U24 data latches, and U5 Manual/Auto/DAC multiplexer.

8-492. To troubleshoot this circuitry, first verify the functional operation of the DAC's by enabling Diagnostic #34 as follows:

Press: SCALE, SMOOTH, 9, 9, ENTER (If not already in diagnostic mode); wait 5 seconds, then press: SCALE, 3, 4, ENTER. 5335A display will show: "DIAG 34".

8-493. For a visual display of DAC's functional operation, connect the suspected channel trigger level (A or B), from the 5335A rear panel to an oscilloscope. The level will vary from -5.11 volts to +5.11 volts continuously. If a problem exist in the DAC's, a "jump" will be noticed in the scope's display, i. e., the sweep on the scope display will not be a smooth one.

8-494. Connect the unused trigger level signal from the 5335A rear panel to the scope, and verify its operation against the defective one. If the display of the DAC's output is not smooth in one channel, but O.K. in the other, exchange U21 with U23 and check if problem travels with IC. If it does, replace defective IC. If it does not, the problem may be located in the data latches U16, U17, or U24.

8-495. To verify proper operation of the DAC's data latches, remove A11U21 an U23 from their sockets, and enable Diagnostic #18 and #19. The logic level of the output of U16, U17, and U24 data latches should be as shown in Table 8-35.

Table 8-35. A11 Data Latch Logic Levels

| DEVICE | DIAG #18 (0 Volt) | DIAG #19 (-5.12 Volts) |
|------------------|-------------------|------------------------|
| CHANNEL A | | |
| U17(2) | 0 | 0 |
| (5) | 0 | 0 |
| (6) | 0 | 0 |
| (9) | 0 | 0 |
| (12) | 0 | 0 |
| (15) | 0 | 0 |
| (16) | 0 | 0 |
| (19) | 0 | 0 |
| U24(11) | 0 | 0 |
| (13) | 1 | 0 |
| CHANNEL B | | |
| U16(2) | 0 | 0 |
| (5) | 0 | 0 |
| (6) | 0 | 0 |
| (9) | 0 | 0 |
| (12) | 0 | 0 |
| (15) | 0 | 0 |
| (16) | 0 | 0 |
| (19) | 0 | 0 |
| U24(3) | 0 | 0 |
| (5) | 1 | 0 |

8-496. Troubleshooting the Data Latch Enablers U19 and U20

8-497. A11U19 and U20 are three-to-eight decoders that clock the following devices: A11U18 relay driver data latch, A11U14 and U15 Front End latch controls, and U16, U17, U24 DACs data latch.

8-498. To verify that U19 and U20 are working properly, set the 5335A to its FREERUN mode. Follow the procedure in paragraph 8-406. Verify the signatures in *Figure 8-96*.

8-499. If A11U19 and U20 input signatures are not correct, trace back to the microprocessor system signatures in A4; see *Table 8-15*. If input signatures are good, but output signatures are bad, suspect U14, U15, U16, U17, U18, U24, and last, U19 and U20.

8-500. Trigger Level Voltmeter Troubleshooting

8-501. This section of A11 is composed of A11U4 multiplexer, U10 voltage-to-frequency converter; it is referenced to a very precise +10 volts supply from A1

power supply assembly. U9B uses the precise +10 volt reference to generate a -5 volt reference used in both U10 and U4. See the Trigger Level Voltmeter Block Diagram, *Figure 8-97*.

8-502. To troubleshoot the Trigger Level DVM, first check U4 control bit pattern; Diagnostics #26 through #33 are used to set up these bit patterns. To enable these diagnostics, press:

- a. SCALE, SMOOTH, 9, 9, ENTER; wait 5 seconds.
- b. press: SCALE, (26 thru 33), ENTER

8-503. After entering SUPER CHECK, select any one of the diagnostics desired. Verify the bit patterns of A11U4 per *Table 8-36*.

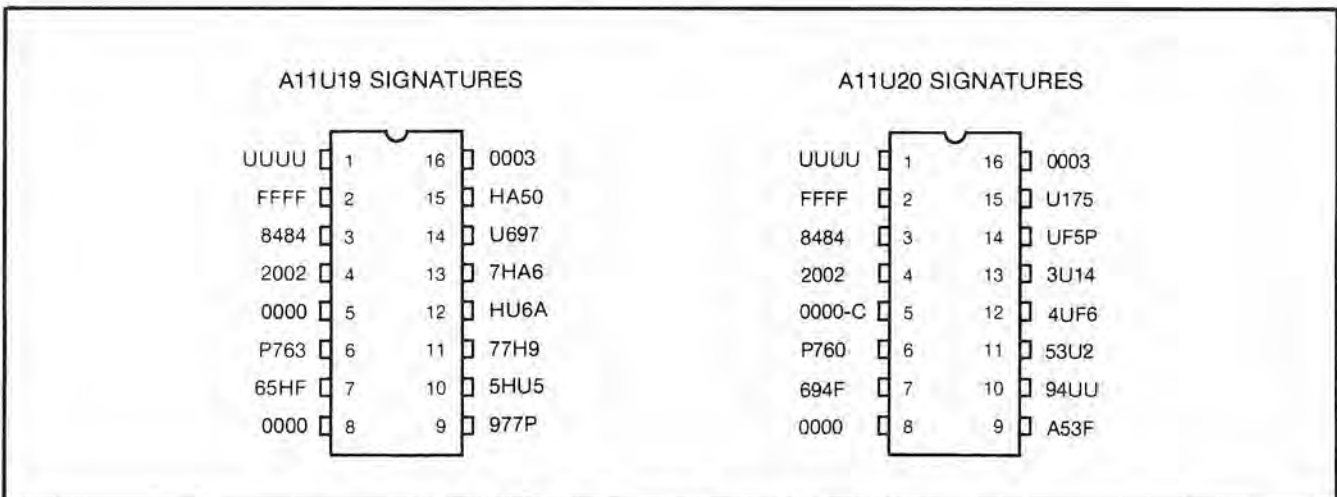

Figure 8-96. A11U19 and A11U20 Signatures

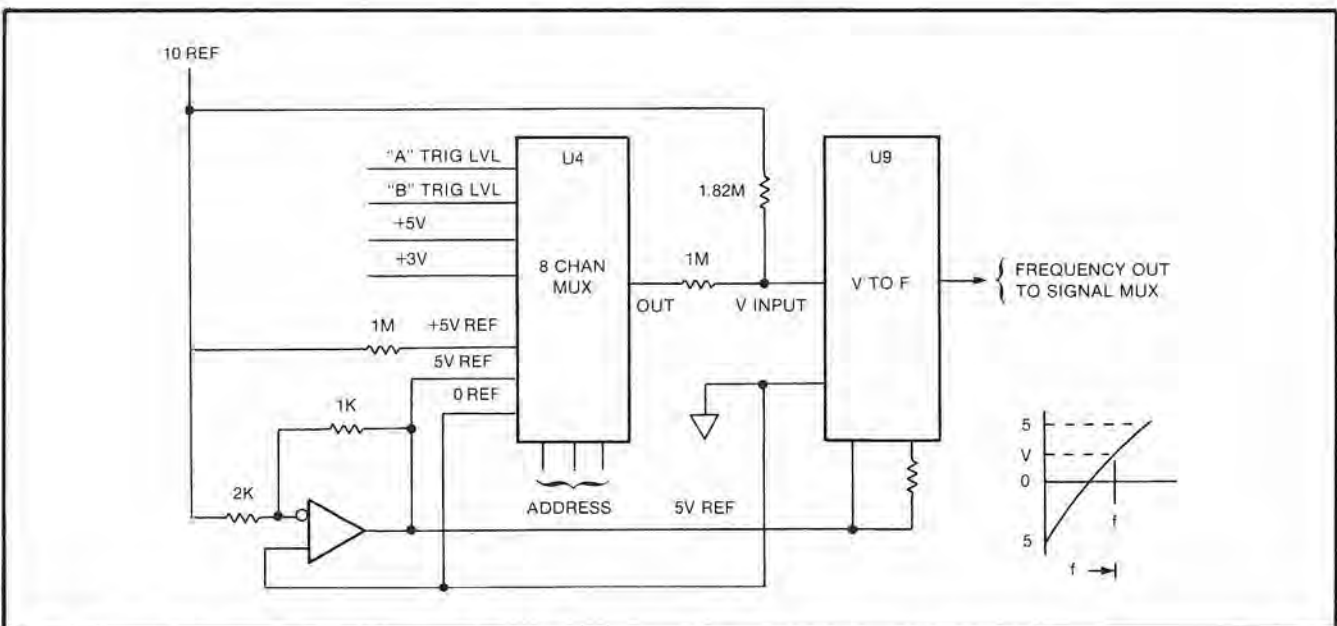

Figure 8-97. Trigger Level DVM Block Diagram

Table 8-36. A11U4 Analog Multiplexer Control Bits

| U4(15) C5 | U4(16) C4 | U4(1) C6 | FUNCTION | DIAG | APPROXIMATE FREQUENCY (at TP11) |
|--------------|--------------|-------------|--------------|------|--|
| 0 | 0 | 0 | Trig Lvl A | 29 | -5.2V 0V +5.2V 100 Hz 1.87 kHz 3.62 kHz |
| 0 | 0 | 1 | Trig Lvl B | 30 | Same as DIAG -29 |
| 0 | 1 | 0 | +5V Supply | 31 | 3.57 kHz |
| 0 | 1 | 1 | +5V Ref. | 28 | 3.56 kHz |
| 1 | 0 | 0 | +3V Supply | 32 | 2.83 kHz |
| 1 | 0 | 1 | Gnd. Ref. | 27 | 1.86 kHz |
| 1 | 1 | 0 | -5V Ref. | 26 | 170 Hz |
| 0 | 0 | 0 | -5.2V Supply | 33 | 90 Hz |

NOTE

“RANGE HOLD” must be set **ON** during these tests.

8-504. While in these diagnostics, with the RANGE HOLD function enabled, the 5335A will display the actual frequency that is counted in the MRC, out of A11U10(10). The approximate frequency given in the previous table will vary from unit to unit.

8-505. In Diagnostic #33 the microprocessor selects U4(4) which is TRIGGER LEVEL A, and A11U2(7), which is the -5.2 volt supply.

Table 8-37. Input Voltage vs Output Frequency

| U4(8) Input Voltage (V) | Output Frequency (Hz) TP11 |
|-------------------------|----------------------------|
| -5 | 162 |
| -4 | 515 |
| -3 | 874 |
| -2 | 1.18K |
| -1 | 1.52K |
| 0 | 1.86K |
| +1 | 2.21K |
| +2 | 2.54K |
| +3 | 2.88K |
| +4 | 3.22K |
| +5 | 3.56K |

NOTE

The output frequency will vary slightly from instrument to instrument. The above table is for information **ONLY**, and gives only an approximation of the voltage-to-frequency relationship.

NOTE

The +10V reference from A1 assembly should be verified to be within $\pm 0.01V$ before troubleshooting the trigger level DVM, since this reference is not correct, the trigger level DVM will not operate correctly.

8-506. If A11U4 bit patterns are verified and U4 input and output correlates, but no corresponding frequency (per Table 8-37) at TP11 [U10(10)], suspect U10 or level translator U8. If everything checks out through the Trigger Level DMV, then check out A11U7, the signal selector multiplexer and associated circuitry.

8-507. Signal Selector Multiplexer Troubleshooting

8-508. A11U7 is a dual 4-to-1 Multiplexer, and it selects which signal is counted into the MRC by way of the microprocessor; the control bits originates in the A11U14, and they are translated to ECL levels by U8. A11U12 is a divide-by-two flip-flop, (controlled by bit C6); used to extend Channel A frequency range for Frequency A, Ratio A/B, and Ratio C/A functions. See Figure 8-98.

8-509. The outputs of A11U7(2 & 15), TP13 and TP12, respectively, as a function of control bits C9 and C10 selected 5335A front panel function, are as listed in Table 8-38.

8-510. Prescaler Troubleshooting

8-511. A11U12 prescales input signal to Channel A by a factor of two. It is enabled by control bit C6, from U15(15). Refer to prescaler in Figure 8-67.

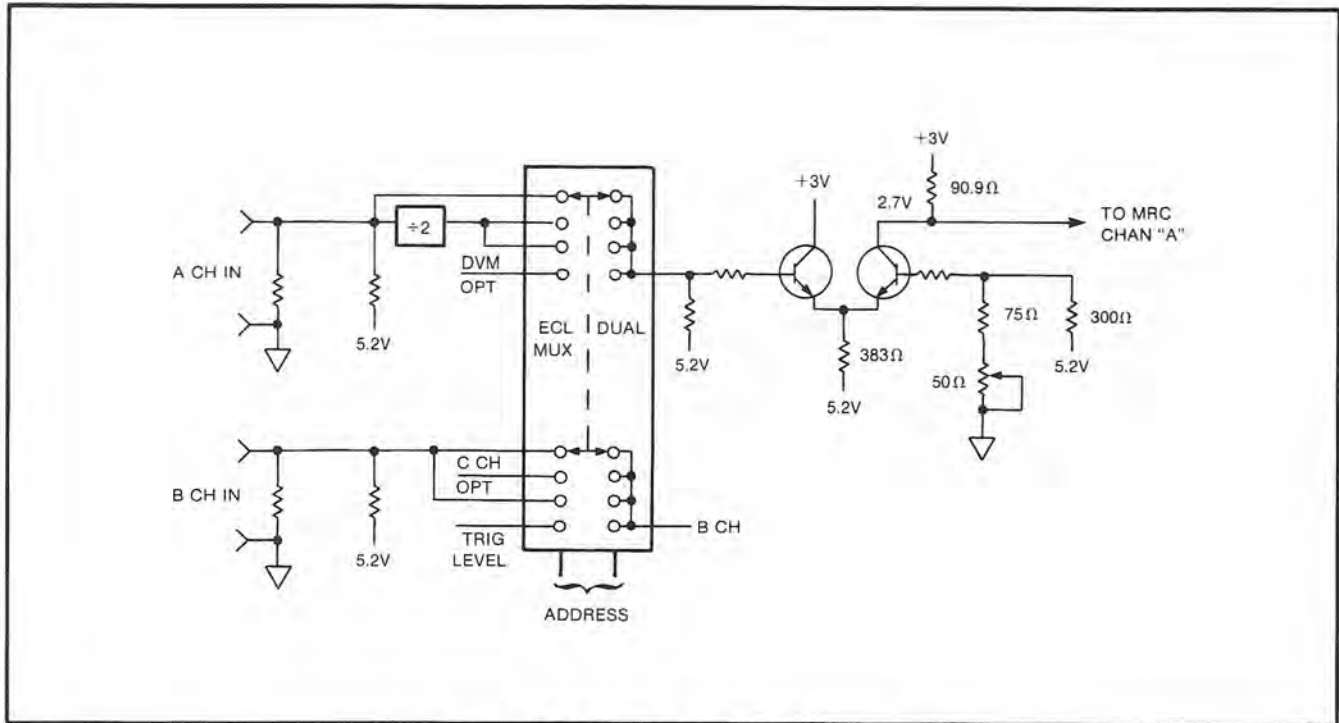

Figure 8-98. Signal Select Block Diagram

Table 8-38. A11U7 Outputs Related to Control Bits C9 and C10

| PANEL FUNCTIONS | U15(15) C6 | U14(7) C9 | U14(10) C10 | U7(2) X | U7(15) Y |
|-------------------------|----------------------------|--------------|----------------|------------|-------------|
| FREQ A | 0 | 0 | 1 | A/2 | B |
| TIME A→B | 1 | 0 | 0 | A | B |
| TOT A | 1 | 0 | 0 | A | B |
| RATIO A/B | 0 | 0 | 1 | A/2 | B |
| FREQ C | 0 | 1 | 0 | | C/20 |
| 1/TIME A→B | 1 | 0 | 0 | A | B |
| PULSE A | 1 | 0 | 0 | A | B |
| RATIO C/A | 0 | 1 | 0 | A/2 | C/20 |
| PER A | 1 | 0 | 0 | A | B |
| RISE A (\uparrow) | 1 | 0 | 0 | A | A |
| FALL A (\downarrow) | 1 | 0 | 0 | A | A |
| SLEW A (\uparrow) | 1/0 | 0/1 | 0/1 | A/DVM | B/Trig Lvl |
| SLEW A (\downarrow) | 1/0 | 0/1 | 0/1 | A/DVM | B/Trig Lvl |
| DUTY CYCLE A | 1 | 0 | 0 | A | B |
| GATE TIME | SAME AS PRECEDING FUNCTION | | | | |
| TRIG LVL | 0 | 1 | 1 | DVM | Trig Lvl |
| VOLTS | 0 | 1 | 1 | DVM | Trig Lvl |
| PHASE A rel B | 0/1 | 0 | 1/0 | A/DVM | B/Trig Lvl |
| FREQ B (17) | 0 | 0 | 1 | A/2 | B |
| TIME B→A (18) | 1 | 0 | 0 | A | B |
| TOT A-B (19) | 1 | 0 | 0 | A | B |
| PULSE B (20) | 1 | 0 | 0 | A | B |

8-512. A12 INPUT AMPLIFIER TROUBLESHOOTING

8-513. The A12 Amplifier Buffer Assembly consist of Input Offset buffer, the Bridge Limiter, the Peak Detectors, and the Amplifier Schmitt, for both channels A and B.

8-514. Input Offset Buffer Troubleshooting

8-515. The Input Offset Buffer is a split band amplifier, one path buffering the high frequency signals,

and the other buffers the low frequency signals (below 10 kilohertz). To troubleshoot the Input Offset Buffer, check the **dc values** at key points, such as:

CHANNEL A

- A12U4 pins 2, 3 and 6 (inputs and output),
- A12U4 pins 1 and 8 (both sides of C35)
- A12Q9, Q10, and Q11 (base emitter collector)

8-516. This check **MUST** be done with **NO INPUT SIGNAL** and **AUTO TRIG** disabled; typical values are shown in Figure 8-99.

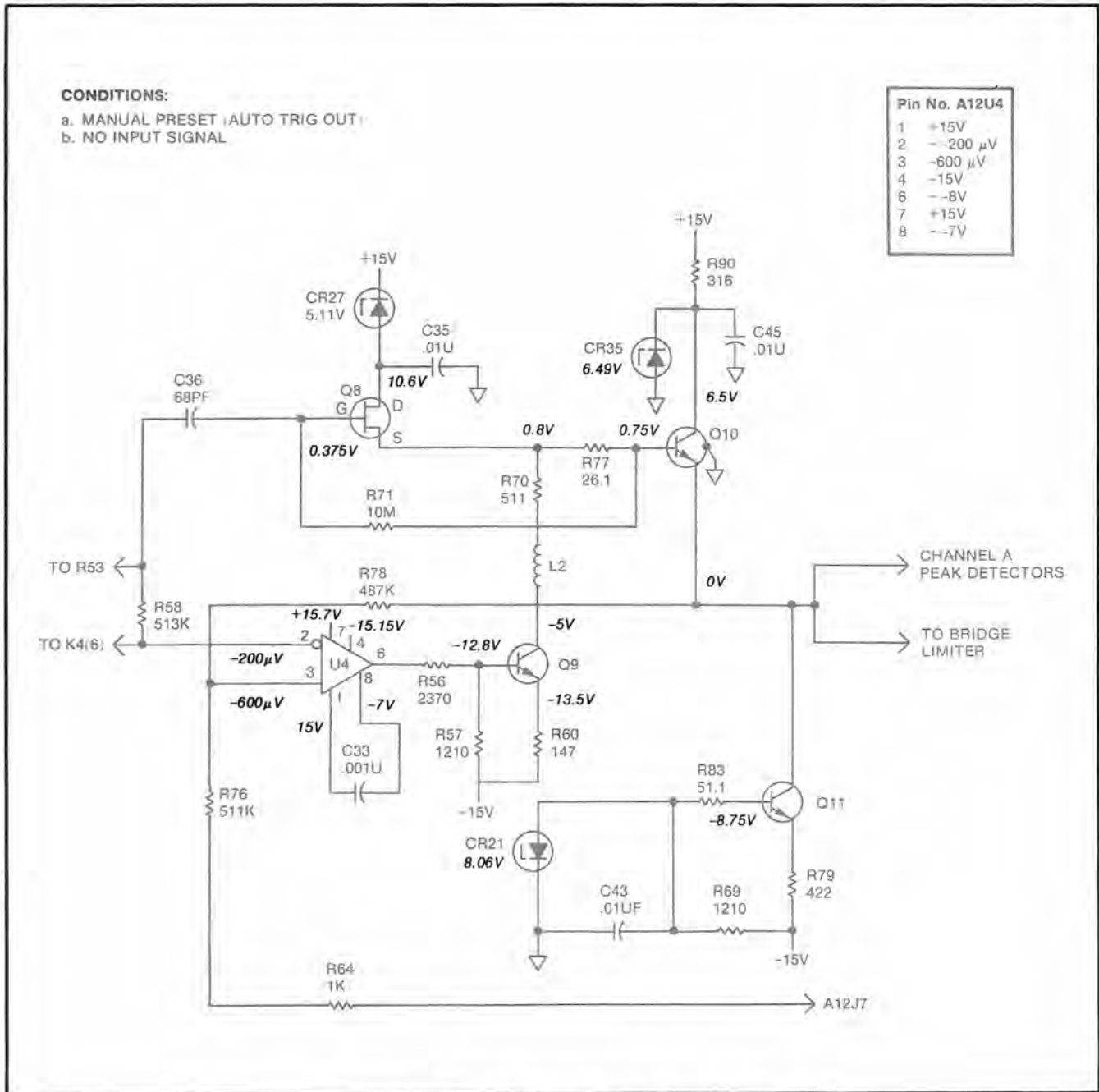

Figure 8-99. Channel A Input Buffer DC Voltages

8-517. These dc values are **very** critical for maintaining the Q points of A12U4 (Channel A) and A12U3 (Channel B). If the values are not present, suspect A12U4, Q8, Q9, Q10, and Q11 (for Channel A). The Input Offset Buffer circuitry for Channel B is identical to Channel A, and it could be used for comparison basis.

8-518. Peak Detectors Troubleshooting

8-519. The Peak Detector circuitry is designed to be used during the AUTO TRIG mode only; they are used to detect the maximum amplitude of the input signal, and the microprocessor will figure out the 10%, 50% and 90% points of input signal, through A11U2 and A11U11. There are two peak detectors per channel: a positive and a negative peak detector. During manual mode of operation, the positive and negative peak detectors are tied to ± 5.2 volts, respectively. The diodes used in the peak detectors are a closely matched set. Refer to Section VI for the part number of the four matched diodes.

8-520. The peak detectors in the A12 assembly complements the channels A and B Trigger Level selector multiplexers, and the peak detector enabling cir-

cuitry, which are located in the A11 Amplifier Support assembly. *Figure 8-100* is the Peak Detector Block Diagram.

8-521. The peak detector circuits are contained in two assemblies: in A12 Amplifier Buffer assembly and in A11 Amplifier Support assembly. The peak detectors themselves are located in the A12 Assembly. The signals that enable and disable the peak detectors originate on the A11 assembly, U15 through U1A, B, C, and D. *Table 8-39* lists the signals that control the peak detectors.

Table 8-39. Peak Detector Control Signals

| PEAK DETECTOR CONDITION U1 (PIN) | SIGNALS AND INTEGRATED CIRCUITS | | | |
|--|---------------------------------|-------------|------------|------------|
| | ANE (8) | APE (14) | BNE (1) | BPE (7) |
| ENABLED | -12.5V | +15.0V | -12.5V | +15.0V |
| DISABLED | +5.2V | -5.2V | +5.2V | -5.2V |

- ANE = "A" NEGATIVE ENABLE (Enables channel A Positive Peak Detector)
- APE = "A" POSITIVE ENABLE (Enables channel A Negative Peak Detector)
- BNE = "B" NEGATIVE ENABLE (Enables channel B Positive Peak Detector)
- BPE = "B" POSITIVE ENABLE (Enables channel B Negative Peak Detector)

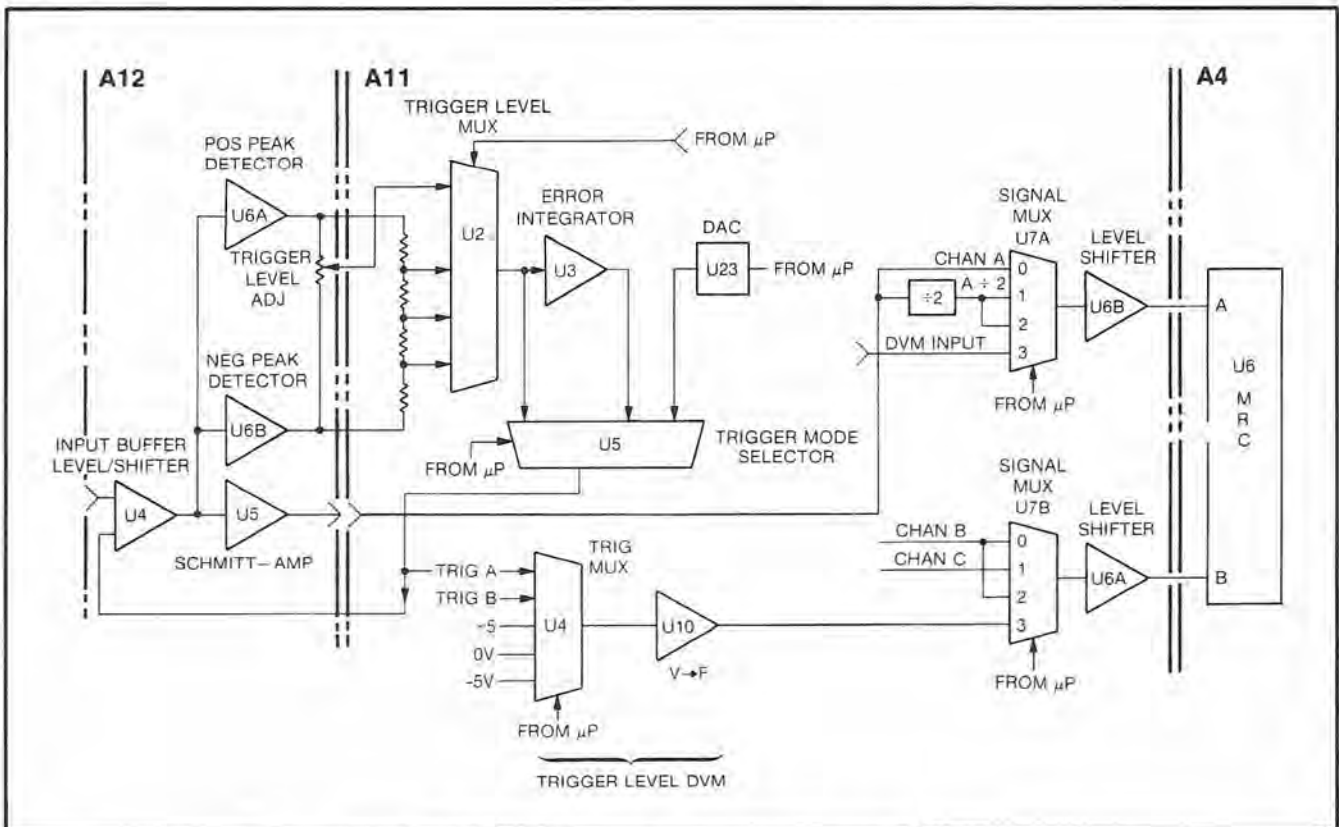

Figure 8-100. Block Diagram of Peak Detectors in A11 and A12

8-522. A12 Troubleshooting Accessories

8-523. To facilitate the troubleshooting of the A12 assembly (outside the counter) procure the following accessories:

- a. Two multiribbon cable assembly, P/N 8120-2463.
- b. Two 50-ohm cable assembly, P/N 05335-60112.
- c. Two SMC male-to-male adapter, P/N 1250-0827.

8-524. A12 Troubleshooting Out-of-Cabinet Setup

- a. Remove the A12 assembly from mainframe.
- b. Replace both multiribbon cable assembly 8120-2867 with longer version, P/N 8120-2463.
- c. Connect two 50-ohm cable assemblies end-to-end, P/N 05335-60112, with a SMC male-to-male adapter, P/N 1250-0827, for both channels A and B. These new connections will facilitate access to key points in the A12 assembly.

8-525. Troubleshooting Peak Detectors in Manual Mode

8-526. To troubleshoot the Peak Detectors, first check their operation in MANUAL mode. To do this, set the 5335A Auto Trigger mode to the OFF condition. Enable TRIG LVL function, and vary the front panel trigger level controls for both channels from ccw to cw positions. The displayed voltage for both channels should be between ± 5.2 volts; the key point is that both peak detectors should display the same readings, ± 10 millivolts.

8-527. In the manual mode, the peak detector outputs are tied to ± 5.2 volts; Verify this voltage at TP "ATL" or at A11U5(8), the ATL line, by varying the channel A trigger level pot on the 5335A front panel. If voltage is not present, back trace through A11U5, A11U2 (channel A trigger level selector), to the APL line.

8-528. Also, verify that peak detectors are truly disabled; check A11U1(8), (14), (1), (7).

8-529. When checking the forward voltage drop of the peak detector diodes, verify that all diodes within each peak detector are matched to within less than 5 mV; if they are not, replace all three diodes.

8-530. Troubleshooting Peak Detectors in Auto Mode

8-531. To troubleshoot peak detectors in AUTO mode, apply a 1 kHz square wave of 500 mV p-p to the 5335A

INPUT A. See *Figure 8-101*. Set the 5335A to AUTO TRIG, and COM A, 50 ohms, X1, dc coupling.

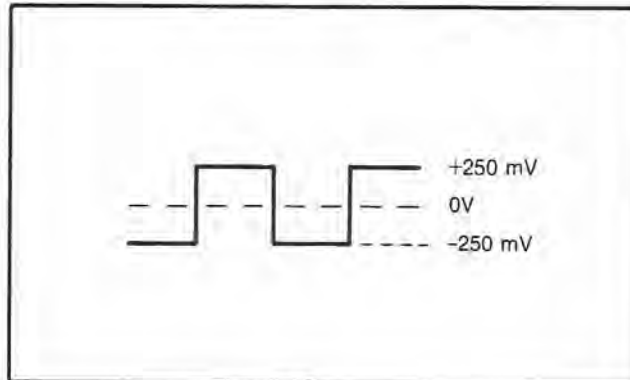

Figure 8-101. Peak Detectors Test Signal

a. Enable TRIG LVL function; rotate the trigger level controls for channel A and B to the ccw position (not in PRESET). Observe the 5335A displaying the peak of signal, $-0.24V \pm 0.01V$. Rotate the trigger level pots to the full cw position and verify a display of $+0.24 \pm 0.01$ volt.

b. Ground the ATL line (connect a jumper from either side of A12R64 to ground). This will force a feedback trigger level of zero volts to A12U4(3), and remove the effect of the peak detectors back into A12U4.

c. Rotate both trigger level pots to the ccw position.

d. Verify the APD line (channel A positive peak detector output) and AND line (channel A negative peak detector output), reflect the true peaks of signal, i.e., about $+230 \text{ mV} \pm 10 \text{ mV}$, and $-230 \text{ mV} \pm 10 \text{ mV}$, respectively. If this voltage is not present, check the voltages of A12U6 per *Figure 8-102* (in volts).

e. To obtain the readings of A12U1 as listed above, ground the BTL line (connect a jumper from either side of A12R47 to ground).

f. If these voltages are not attained, verify that the peak detectors are fully enabled by A11U1. If they are not fully enabled, suspect A11U1. If they are enabled by proper voltage, try adjusting peak detectors; refer to adjustment procedure in Section V.

g. If they cannot be adjusted, suspect A12U6; also replace matched set of diodes A12CR31, CR32 and CR36 ("A" positive peak detector), A12CR33, CR34, CR37 ("A" negative peak detector), C52, C53, C55, C55, C55, C59.

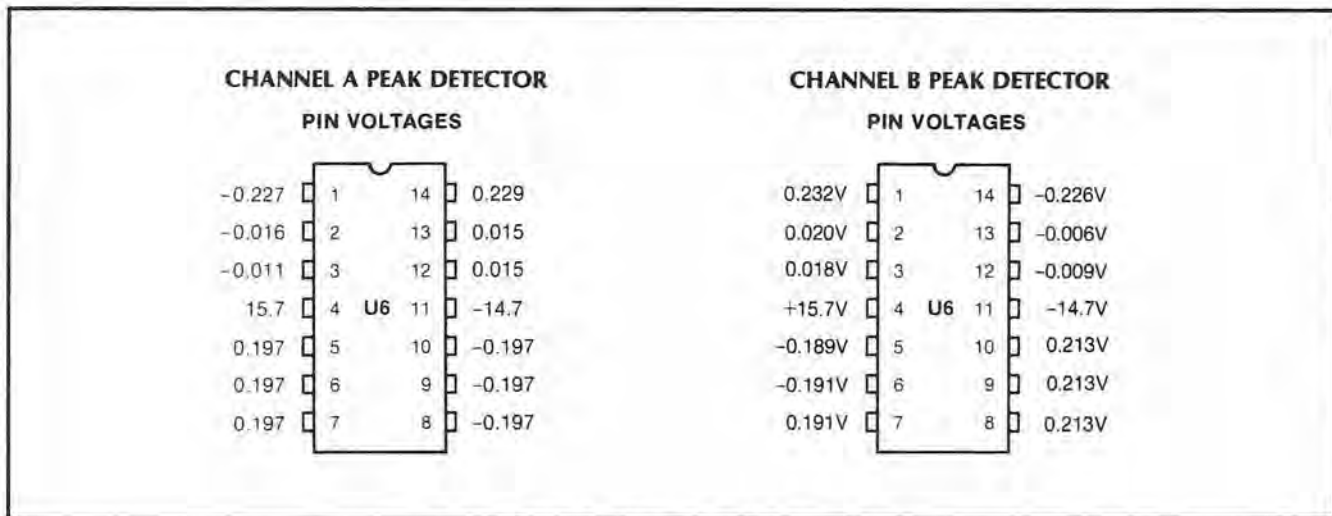

Figure 8-102. A12U6 and A12U1 Pin Voltages

8-532. Schmitt Amplifier Troubleshooting

8-533. The best way to verify the proper operation of the Schmitt amplifier is by checking its hysteresis. Refer to Input Amplifier adjustment procedure. The amplifier must be adjustable to between 18 and 20 mV peak-to-peak; refer to paragraphs 8-398 and 8-400 if amplifier cannot be adjusted to these limits; also suspect A12U5 (channel A) or A12U2 (channel B).

8-534. Bridge Limiter Troubleshooting

8-535. The bridge limiter is composed of A12CR25, 26, 29, 30, and it serves to protect the A12U5 Schmitt amplifier (Channel A) from overvoltage without distorting the signal on the receiving end.

8-536. Check that the forward voltage drop across each diode is matched within less than 5 mV of each other.

8-537. The four diodes are a closely matched set, and if one or more diode has to be replaced, all four MUST be replaced; see Section VI.

8-538. DIAGRAMS AND PHOTOS

8-539. Block Diagrams, schematic diagrams, and component locator photographs for physical assemblies in the 5335A are on the following foldout pages.

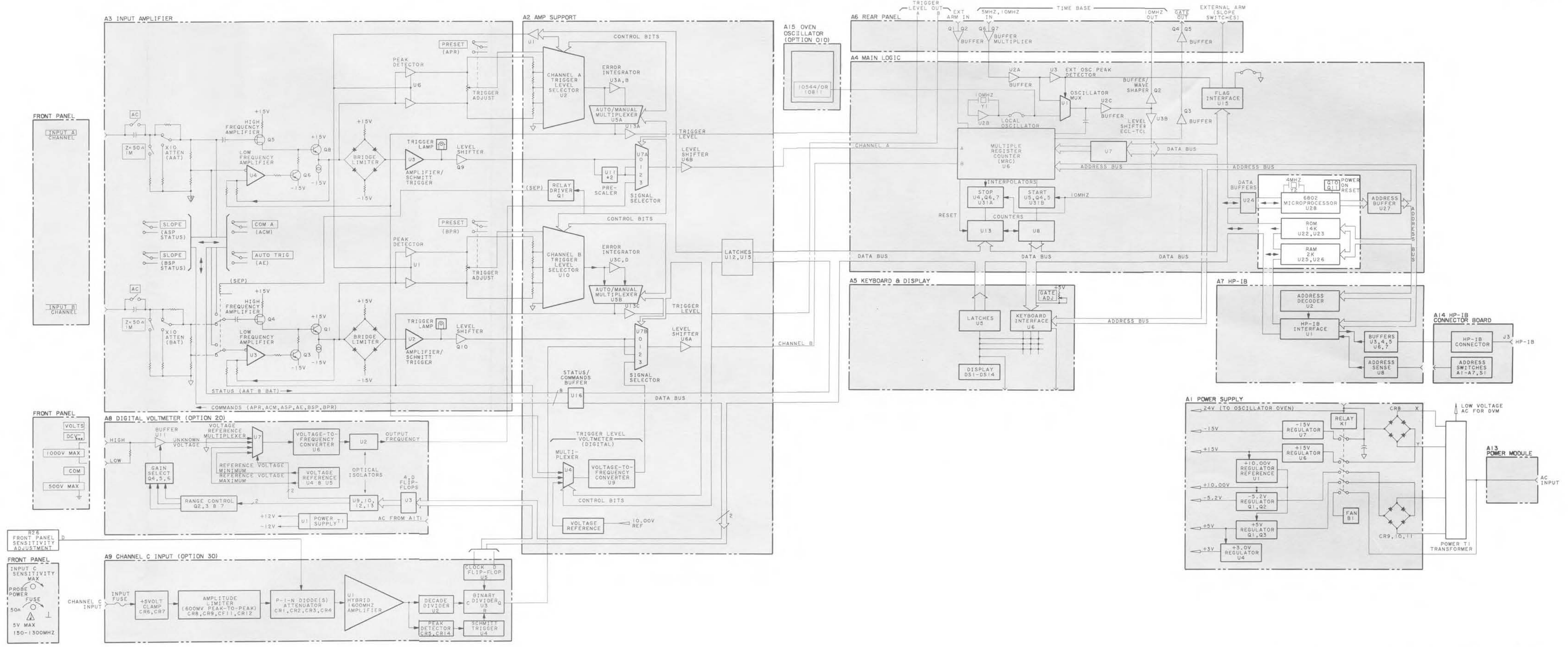

Figure 8-103. 5335A Block Diagram with Options 010, 020, and 030

Figure 8-103
5335A BLOCK DIAGRAM WITH OPTIONS 010, 020, AND 030

(See Page 8-97)

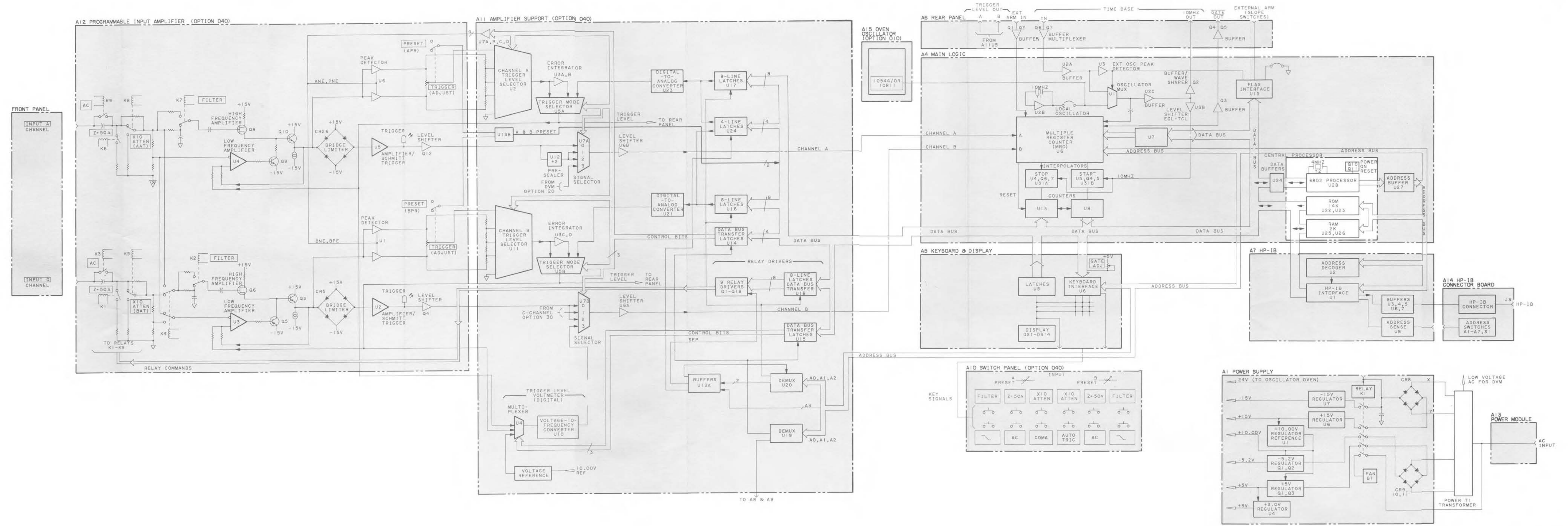

Figure 8-104. 5335A Block Diagram with Option 040

Figure 8-104
5335A BLOCK DIAGRAM WITH OPTION 040
(See Page 8-99)

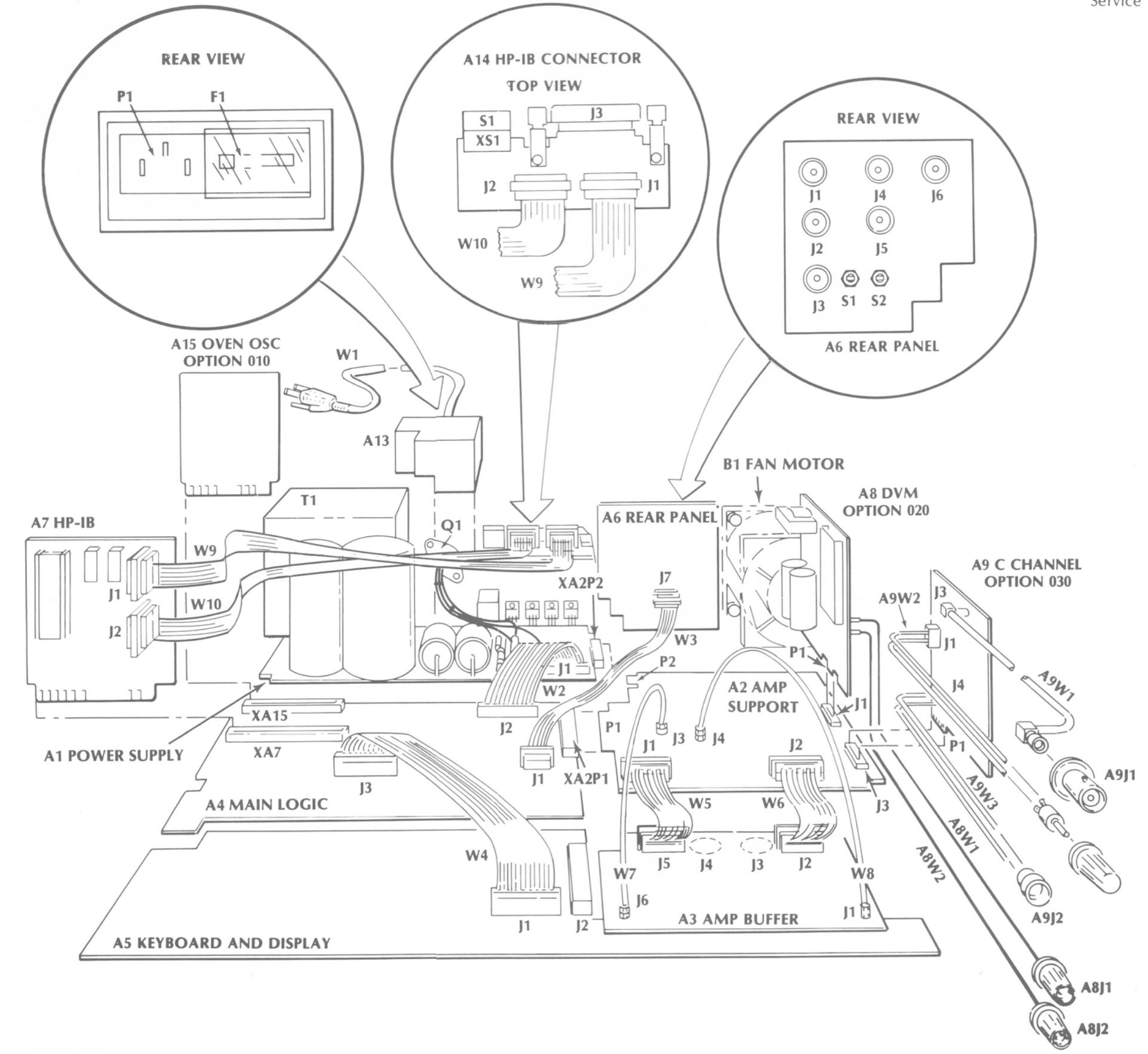

Figure 8-105. Assembly and Cable Locator with Options 010, 020, and 030

Figure 8-105
ASSEMBLY AND CABLE LOCATOR WITH OPTIONS 010, 020, AND 030

(See Page 8-101)

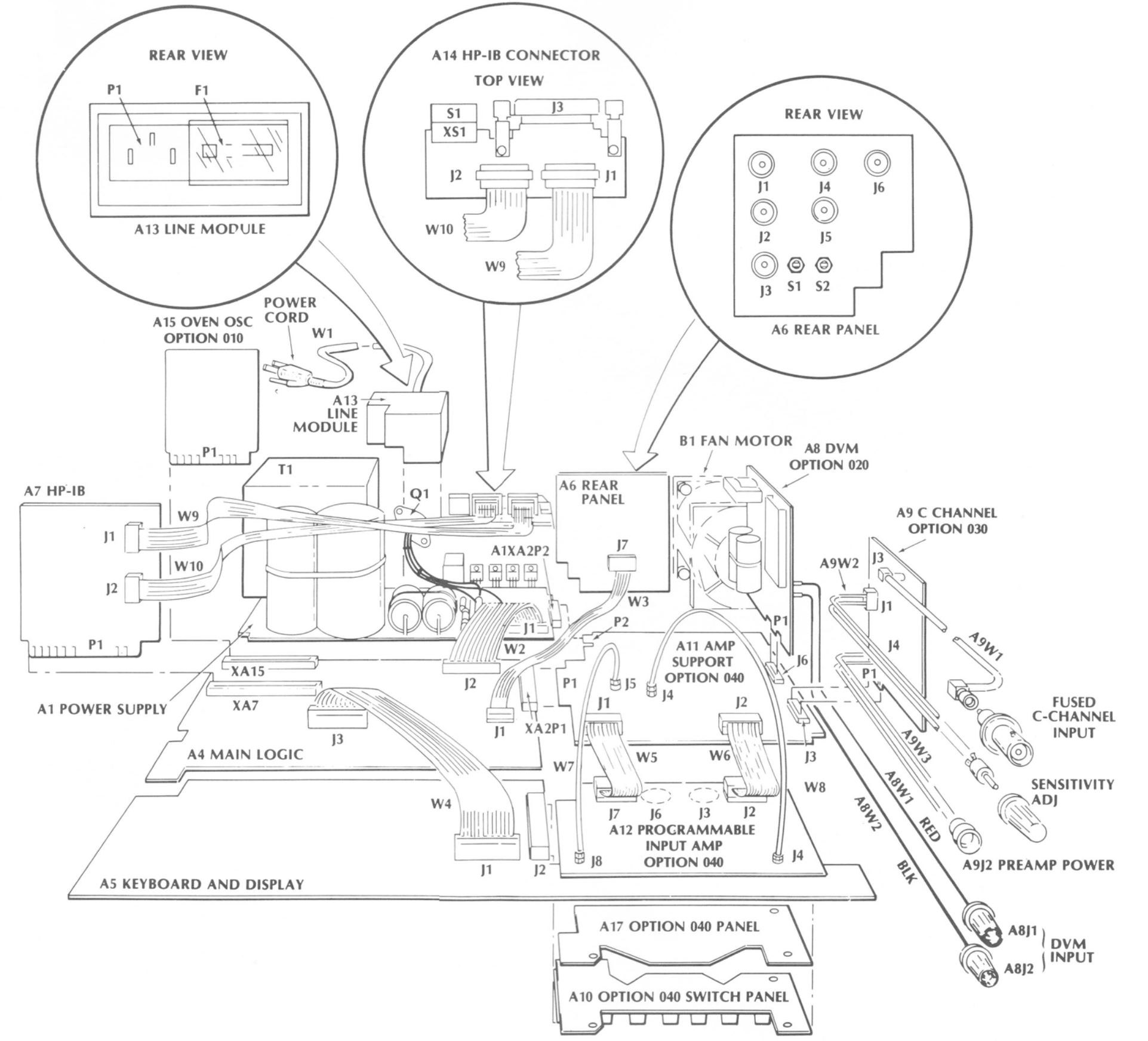
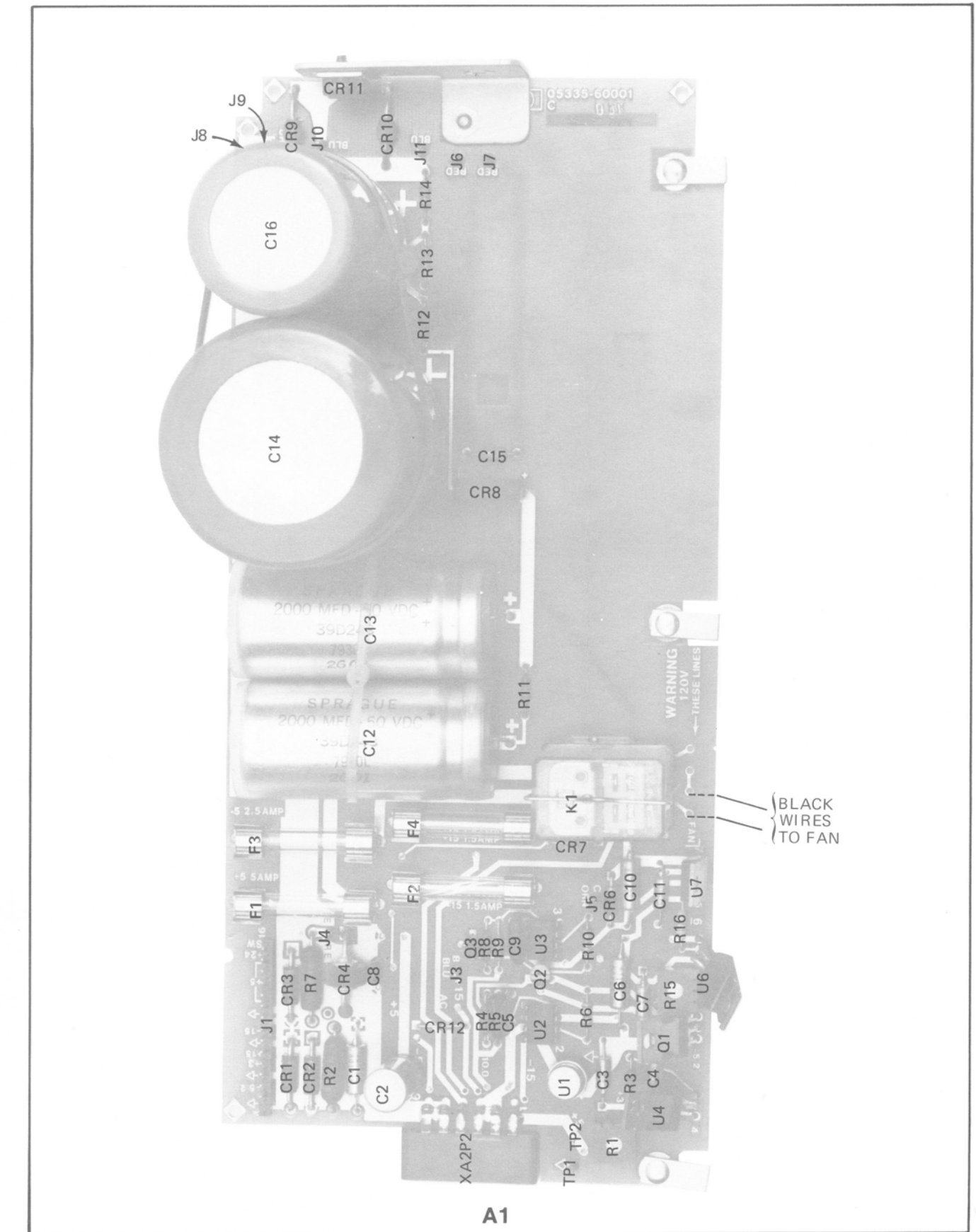

Figure 8-106. Assembly and Cable Locator with Option 040



Part of Figure 8-107. A1 Power Support and A13 Line Module Assembly

Figure 8-106
ASSEMBLY AND CABLE LOCATOR WITH OPTION 040

(See Page 8-103)

NOTES

1. REFERENCE DESIGNATIONS WITHIN THIS ASSEMBLY ARE ABBREVIATED. ADD ASSEMBLY NUMBER TO ABBREVIATION FOR A COMPLETE REFERENCE DESIGNATION.
2. UNLESS OTHERWISE INDICATED: RESISTANCE IN OHMS CAPACITANCE IN FARADS INDUCTANCE IN HENRIES
3. ASTERISK (*) INDICATES FACTORY SELECTED COMPONENT VALUE. AVERAGE VALUE SHOWN. PART MAY NOT BE IN ALL INSTRUMENTS.

A1 REFERENCE DESIGNATORS

- A1C1-C16
- A1CR1-CR4, CR6-CR12
- A1F1-F4
- A1J1-J11
- A1K1
- A1Q1-Q3
- A1R1-R16
- A1TP1,TP2
- A1U1-U7

A1 ACTIVE COMPONENTS

| REFERENCE | HP PART NO. |
|------------|--------------|
| A1CR1,CR3 | 1902-0522 |
| A1CR2 | 1902-0632 |
| A1CR4 | 1901-0662 |
| A1CR5 | NOT ASSIGNED |
| A1CR6 | 1901-0731 |
| A1CR7,CR12 | 1901-0050 |
| A1CR8 | 1906-0096 |
| A1CR9,CR10 | 1901-0673 |
| A1CR11 | 1906-0213 |
| A1Q1 | 1853-0454 |
| A1Q2 | 1853-0036 |
| A1Q3 | 1854-0215 |
| A1U1 | 1826-0216 |
| A1U2,U3 | 1820-0477 |
| A1U4 | 1826-0393 |
| A1U5 | NOT ASSIGNED |
| A1U6 | 1826-0607 |
| A1U7 | 1826-0214 |

CONNECTOR PIN TABLES:

A1-A2 CONNECTIONS

| A1XA2 | A2P2 | DESCRIPTION |
|-------|------|--------------------|
| (1) | (1) | +5 Volts |
| (2) | (2) | GROUND |
| (3) | (3) | GROUND |
| (4) | (4) | AC DVM Supply |
| (5) | (5) | GROUND |
| (6) | (6) | GROUND |
| (T) | (T) | -15 Volts |
| (2) | (2) | +10 Volt Reference |
| (3) | (3) | +15.7 Volts |
| (4) | (4) | AC DVM Supply |
| (5) | (5) | GROUND |
| (6) | (6) | -5.2 Volts |

A1-A4 CONNECTIONS

| A1J1 | A4J2 | DESCRIPTION |
|------|------|--------------------------|
| 1 | 1 | GROUND (Clean) |
| 2 | 2 | N.C. (Key) |
| 3 | 3 | -5.2 Volts |
| 4 | 4 | GROUND (Clean) |
| 5 | 5 | +3 Volts |
| 6 | 6 | +15 Volts |
| 7 | 7 | GROUND |
| 8 | 8 | -15 Volts |
| 9 | 9 | GROUND |
| 10 | 10 | GROUND |
| 11 | 11 | +5 Volts |
| 12 | 12 | +5 Volts |
| 13 | 13 | +5 Volts |
| 14 | 14 | +5 Volts |
| 15 | 15 | +24 Volts (to Osc) |
| 16 | 16 | +24 Volts - Power Switch |

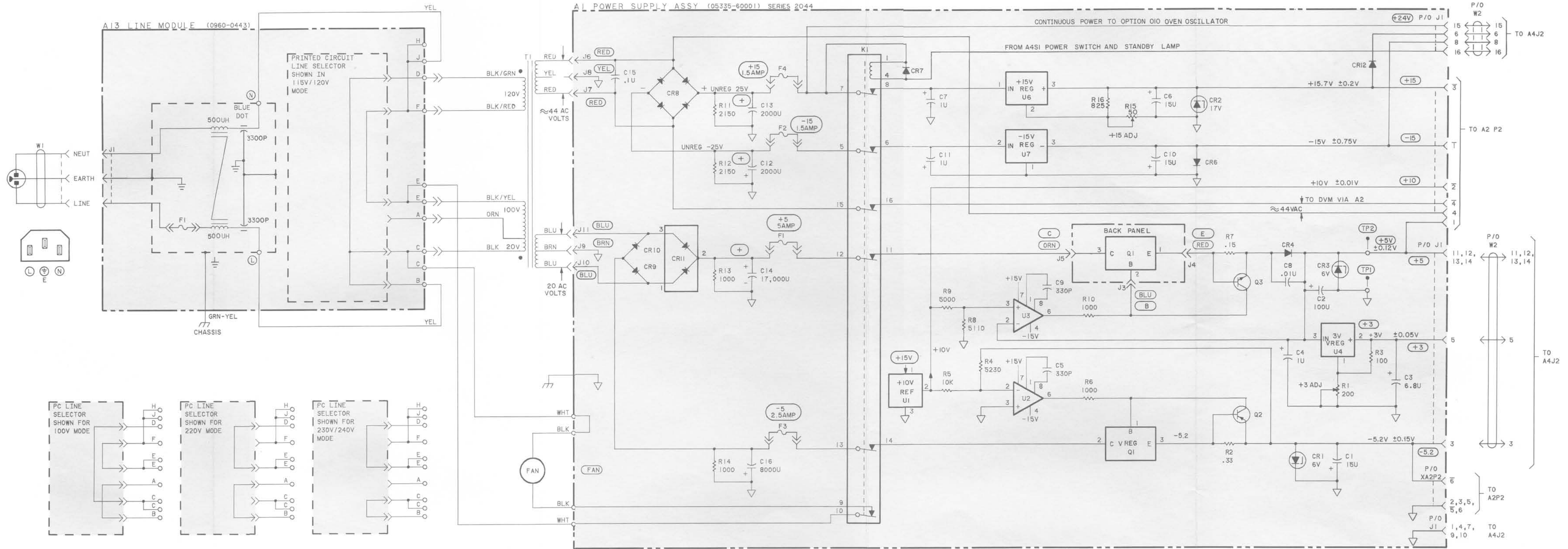
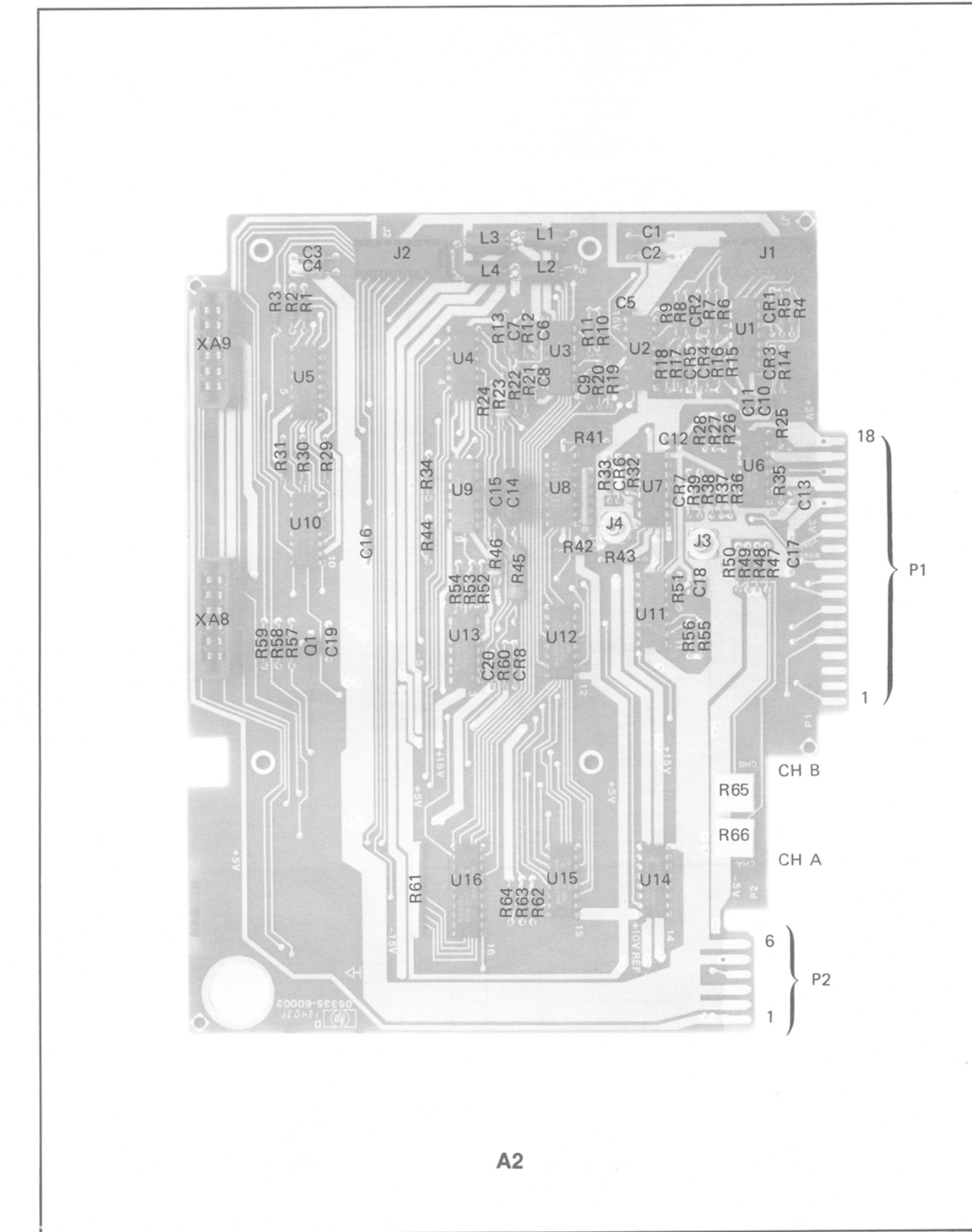

Figure 8-107. A1 Power Supply Assembly and A13 Line Module

Figure 8-107
A1 POWER SUPPLY ASSEMBLY AND A13 LINE MODULE
(See Page 8-105)



Part of Figure 8-108. A2 Amplifier Support Assembly

NOTES

- REFERENCE DESIGNATIONS WITHIN THIS ASSEMBLY ARE ABBREVIATED. ADD ASSEMBLY NUMBER TO ABBREVIATION FOR A COMPLETE REFERENCE DESIGNATION.
- UNLESS OTHERWISE INDICATED:
RESISTANCE IN OHMS
CAPACITANCE IN FARADS
INDUCTANCE IN HENRIES
- ASTERISK (*) INDICATES FACTORY SELECTED COMPONENT VALUE. AVERAGE VALUE SHOWN. PART MAY NOT BE IN ALL INSTRUMENTS.
- W7 AND W8 ARE 50-OHM COAXIAL CABLES.

A2 REFERENCE DESIGNATORS

| |
|-----------|
| A2C1-C20 |
| A2CR1-CR8 |
| A2U1-U4 |
| A2L1-L4 |
| A2Q1 |
| A2R1-R66 |
| A2U1-U16 |
| A2W1,W2 |

A2 ACTIVE COMPONENTS

| REFERENCE | HP PART NO. |
|---------------|--------------|
| A2CR1,CR2 | 1901-0376 |
| A2CR3,CR5,CR8 | 1901-0050 |
| A2CR6,CR7 | NOT ASSIGNED |
| A2Q1 | 1854-0246 |
| A2U1,U3,U13 | 1826-0315 |
| A2U2,U4,U10 | 1826-0609 |
| A2U5 | 1826-0610 |
| A2U6 | 1858-0040 |
| A2U7 | 1820-1359 |
| A2U8 | 1820-1173 |
| A2U9 | 1826-0575 |
| A2U11 | 1820-0794 |
| A2U12,U15 | 1820-1196 |
| A2U14 | 1820-1240 |
| A2U16 | 1820-1917 |

CONNECTOR PIN TABLES:

A2-A1 CONNECTIONS

| A2P2 | A1XA2 | DESCRIPTION |
|------|-------|-----------------------|
| (1) | (1) | +5 Volts |
| (2) | (2) | GROUND |
| (3) | (3) | GROUND |
| (4) | (4) | AC DVM Supply |
| (5) | (5) | GROUND |
| (6) | (6) | GROUND |
| (1) | (1) | DVM Output (Freq) |
| (2) | (2) | AC Supply (18.5V rms) |
| (3) | (3) | Data Line 5 |
| (4) | (4) | Data Line 6 |
| (5) | (5) | Data Line 7 |
| (6) | (6) | Data Line 4 |

A2-A3 CONNECTIONS

| A2 | A3 | DESCRIPTION |
|----|----|-------------------|
| | | SEE A3 PAGE 8-109 |

A2-A4 CONNECTIONS

| A2P1 | A4XA2P1 | DESCRIPTION |
|------|---------|-----------------|
| (1) | (1) | LAOE |
| (2) | (2) | R/W (not used) |
| (3) | (3) | A5 (not used) |
| (4) | (4) | A4 (not used) |
| (5) | (5) | A3 |
| (6) | (6) | D7 |
| (7) | (7) | D5 |
| (8) | (8) | D3 |
| (9) | (9) | D1 |
| (10) | (10) | BTL |
| (11) | (11) | NC |
| (12) | (12) | ATL |
| (13) | (13) | NC |
| (14) | (14) | +3 Volts |
| (15) | (15) | CH B to MRC |
| (16) | (16) | +3 Volts |
| (17) | (17) | CH A to MRC |
| (18) | (18) | +3 Volts |
| (1) | (1) | L(VMAE) |
| (2) | (2) | LBOE (not used) |
| (3) | (3) | A2 |
| (4) | (4) | A1 |
| (5) | (5) | A0 |
| (6) | (6) | D6 |
| (7) | (7) | D4 |
| (8) | (8) | D2 |
| (9) | (9) | D0 |
| (10) | (10) | GROUND |
| (11) | (11) | NC |
| (12) | (12) | NC |
| (13) | (13) | NC |
| (14) | (14) | +3 Volts |
| (15) | (15) | +3 Volts |
| (16) | (16) | +3 Volts |
| (17) | (17) | +3 Volts |
| (18) | (18) | +3 Volts |

A2-A8 CONNECTIONS

| A2XA8 | A8P1 | DESCRIPTION |
|-------|------|-----------------------|
| 1 | 1 | GROUND |
| 2 | 2 | AC Supply (18.5V rms) |
| 3 | 3 | ENABLE |
| 4 | 4 | +5 Volts |
| 5 | 5 | GROUND (Option IN) |
| 6 | 6 | GROUND |
| 1 | 1 | DVM Output (Freq) |
| 2 | 2 | AC Supply (18.5V rms) |
| 3 | 3 | Data Line 5 |
| 4 | 4 | Data Line 6 |
| 5 | 5 | Data Line 7 |
| 6 | 6 | Data Line 4 |

A2-A9 CONNECTIONS

| A2XA9 | A9P1 | DESCRIPTION |
|-------|------|------------------|
| 1 | 1 | GROUND |
| 2 | 2 | ENABLE |
| 3 | 3 | +15.7 Volts |
| 4 | 4 | Channel C Output |
| 5 | 5 | -5.2 Volts |
| 6 | 6 | GROUND |
| 1 | 1 | NC |
| 2 | 2 | NC |
| 3 | 3 | NC |
| 4 | 4 | +5 Volts |
| 5 | 5 | D6 |
| 6 | 6 | D7 |

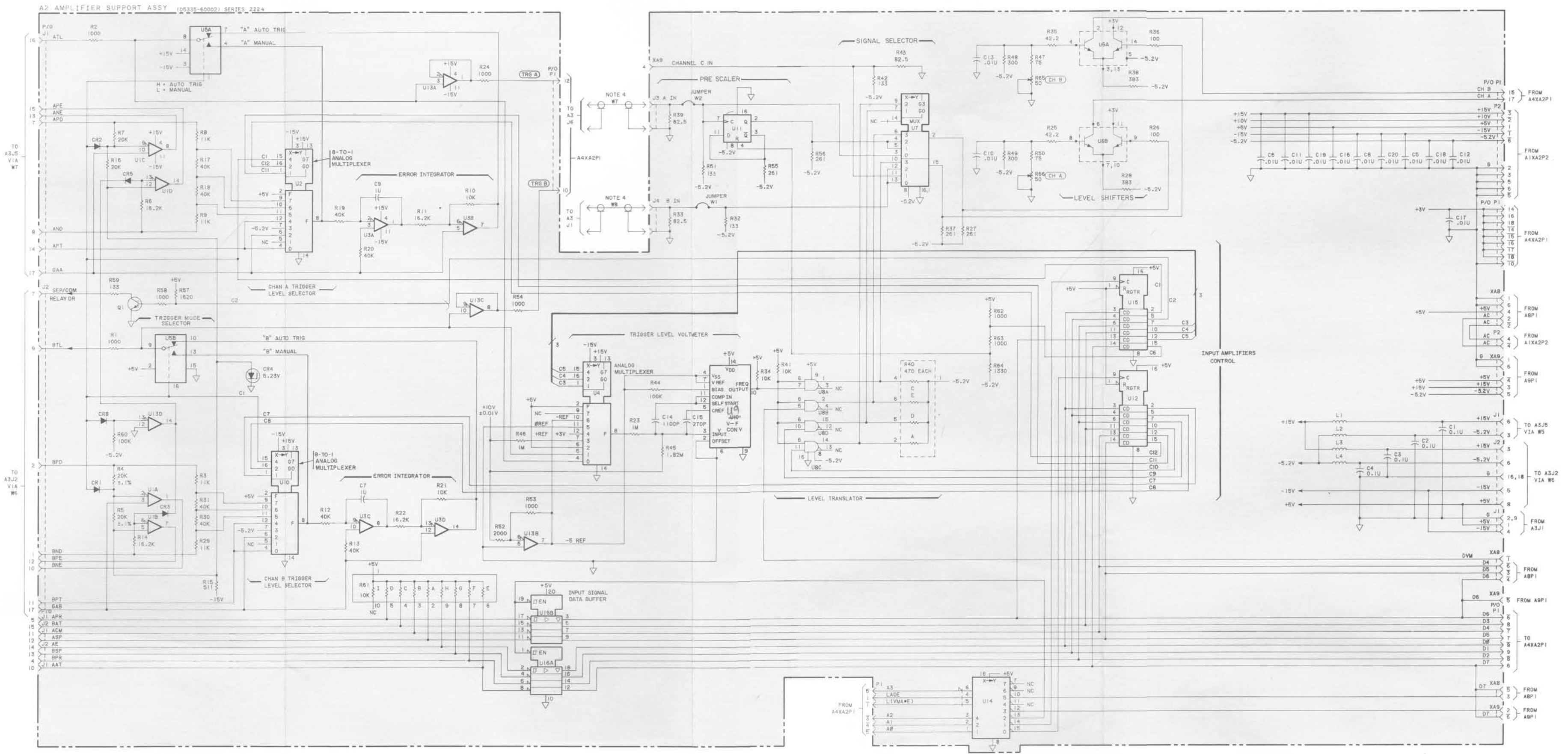
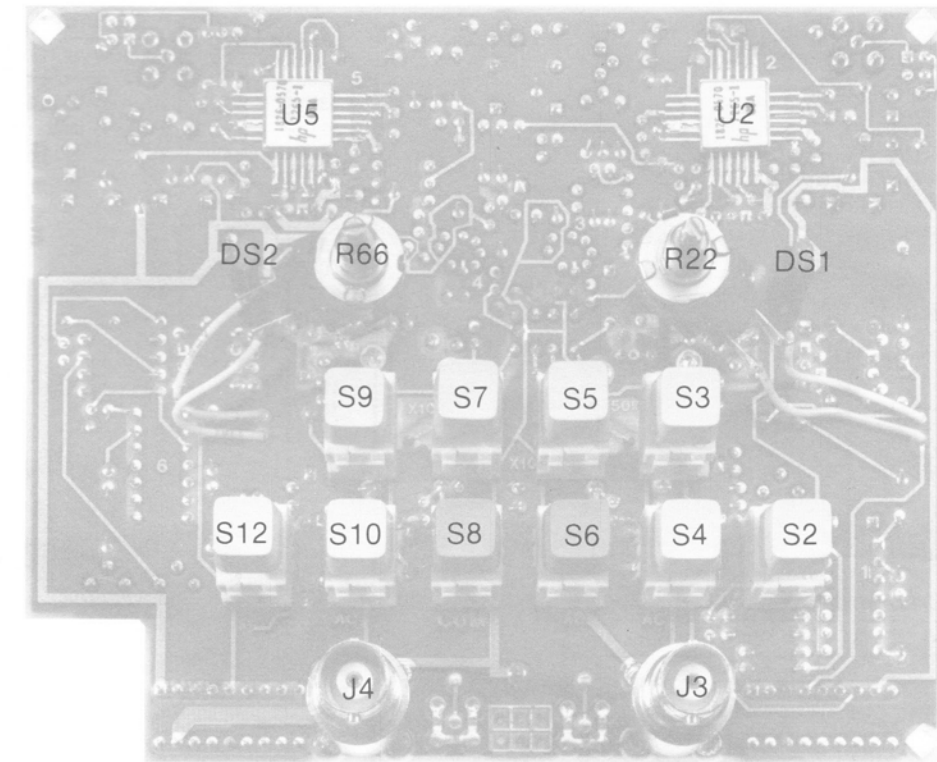
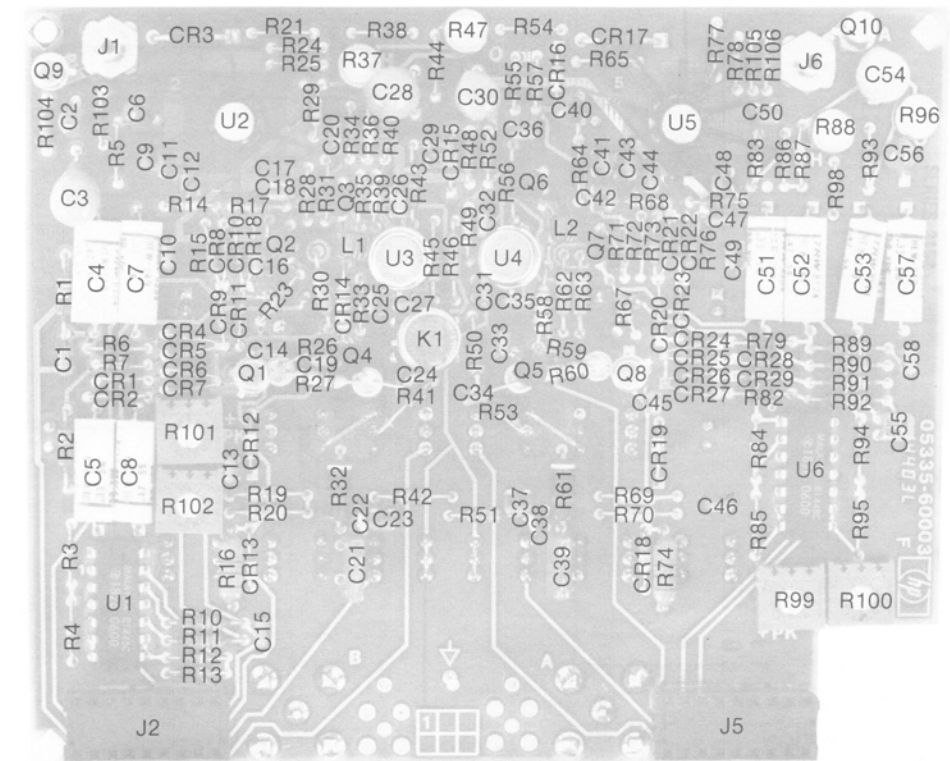

Figure 8-108. A2 Amplifier Support Assembly



A3 FRONT



A3 REAR

Figure 8-108
A2 AMPLIFIER SUPPORT ASSEMBLY

(See Page 8-107)

Part of Figure 8-109. A3 Input Amplifier Buffer Assembly

NOTES

- REFERENCE DESIGNATIONS WITHIN THIS ASSEMBLY ARE ABBREVIATED. ADD ASSEMBLY NUMBER TO ABBREVIATION FOR A COMPLETE REFERENCE DESIGNATION.
- UNLESS OTHERWISE INDICATED: RESISTANCE IN OHMS CAPACITANCE IN FARADS INDUCTANCE IN HENRYS
- ASTERISK (*) INDICATES FACTORY SELECTED COMPONENT VALUE. AVERAGE VALUE SHOWN. PART MAY NOT BE IN ALL INSTRUMENTS.
- MATCHED SETS OF DIODES; CR1,4,5.; CR2,6,7; CR8-11; CR20-23; CR24,25,28; CR26,27,29.
- R1, R11, R89; & R90 ALTERNATE VALUE IS 3.16M.
- PIN CONNECTIONS FOR ACTIVE ELEMENTS:

A3 REFERENCE DESIGNATORS

- A3C1-C58, C60
- A3CR1-CR29
- A3DS1, DS2
- A3J1-J6
- A3K1
- A3L1,L2
- A3Q1-Q10
- A3R1-R6,R9-R79,R82-R106
- A3S1-S12
- A3U1-U6

A3 ACTIVE COMPONENTS

| REFERENCE | HP PART NO. |
|------------------|------------------------|
| A3CR1,CR4,CR5 | 05335-80003* |
| A3CR2,CR6,CR7 | 05335-80003* |
| A3CR3 | NOT ASSIGNED |
| A3CR8-CR11 | 05335-80003* |
| A3CR12,CR19 | 1902-0041 |
| A3CR13,CR18 | 1902-0057 |
| A3CR14 | 1901-0050 |
| A3CR15,CR16 | 1902-3136 |
| A3CR17 | 1901-1080 |
| A3CR20-CR23 | 05335-80003* |
| A3CR24,CR25,CR28 | 05335-80003* |
| A3CR26,CR27,CR29 | 05335-80003* |
| A3DS1,DS2 | 1990-0487 |
| A3Q1,Q8-Q10 | 1854-0686 |
| A3Q2,Q3,Q6,Q7 | 1854-0636 |
| A3Q4,Q5 | 1855-0300 or 1855-0212 |
| A3U1,U6 | 1826-0600 |
| A3U2,U5 | 1826-0570 |
| A3U3,U4 | 1826-0035 |

*Matched Set of Four Diodes

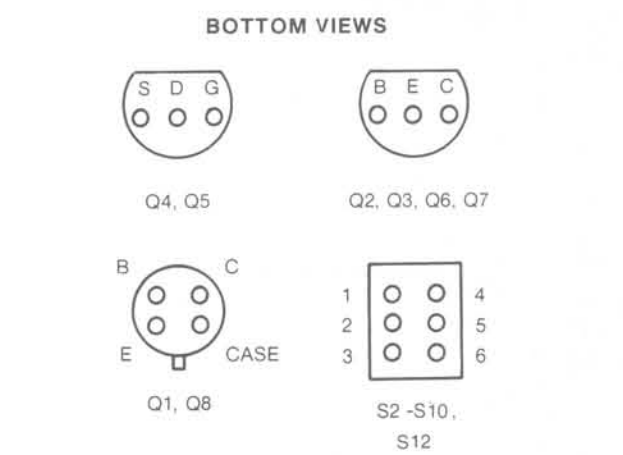

- A3U5 AND U2 PIN DESIGNATION: PINS 1, 2, 6, 8, 12, 16, 20, 23 ARE NOT CONNECTED.

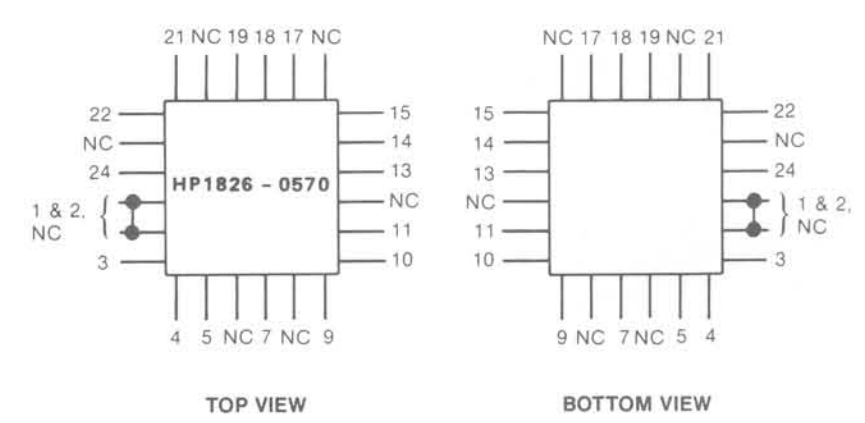

U2 AND U5

NOTES

CONNECTOR PIN TABLES:

| CONNECTIONS A3 to A2 | | | |
|----------------------|------|----------|--|
| A3J1 | A2J5 | MNEMONIC | FUNCTION |
| (1) | (1) | +5 | +5 Volt Supply |
| (2) | (2) | GND | Ground Return |
| (3) | (3) | -5.2 | -5.2 Volt Supply |
| (4) | (4) | -15 | -15 Volt Supply |
| (5) | (5) | APR | Ch "A" preset switch status (PRESET/non PRESET = 5V/0V) |
| (6) | (6) | +15 | +15 volt supply |
| (7) | (7) | APD | Channel "A" positive peak detector output |
| (8) | (8) | AND | Channel "A" negative peak detector output |
| (9) | (9) | GND | Ground Return |
| (10) | (10) | AAT | Channel "A" Atten. 0V/5V = X10/X1 |
| (11) | (11) | ACM | Channel A Common |
| (12) | (12) | ASP | Channel A Slope (/ = 5V/0V) |
| (13) | (13) | ANE | Channel A positive peak detector enable |
| (14) | (14) | APT | Channel A Trigger Level Pot |
| (15) | (15) | APE | Channel A Negative Peak Detector Enable |
| (16) | (16) | ATL | Trigger Level to A Channel |
| (17) | (17) | GAA | Analog Ground A Channel |
| (18) | (18) | N/C | |
| <hr/> | | | |
| A3J2 | A2J2 | MNEMONIC | FUNCTION |
| (1) | (1) | BND | Channel B negative peak detector output |
| (2) | (2) | BPD | Channel B positive peak detector output |
| (3) | (3) | +15 | +15 volt supply |
| (4) | (4) | BPR | Channel B preset switch status (PRESET/non PRESET = 5V/0V) |
| (5) | (5) | -15 | -15 volt supply |
| (6) | (6) | -5.2 | -5.2 volt supply |
| (7) | (7) | SEP | Common/separate relay (3.5V/15.5V = SEP/COM) |
| (8) | (8) | +5 | +5 volt supply |
| (9) | (9) | BTL | Trigger Level to B Channel |
| (10) | (10) | BNE | Channel B positive peak detector enable |
| (11) | (11) | BPT | Channel B Trigger Level Pot |
| (12) | (12) | BPE | Channel B negative peak detector enable |
| (13) | (13) | BSP | Channel B Slope (/ = 5V/0V) |
| (14) | (14) | AE | AUTO TRIG enable (ON/OFF = 0V/5V) |
| (15) | (15) | BAT | Channel "B" Attenuator (0V/5V = X10/X1) |
| (16) | (16) | GND | Ground Return |
| (17) | (17) | GAB | Analog Ground B Channel |
| (18) | (18) | GND | Ground Return |

A2J1 to A3J5 Channel A output
A2J2 to A3J2 Channel B output

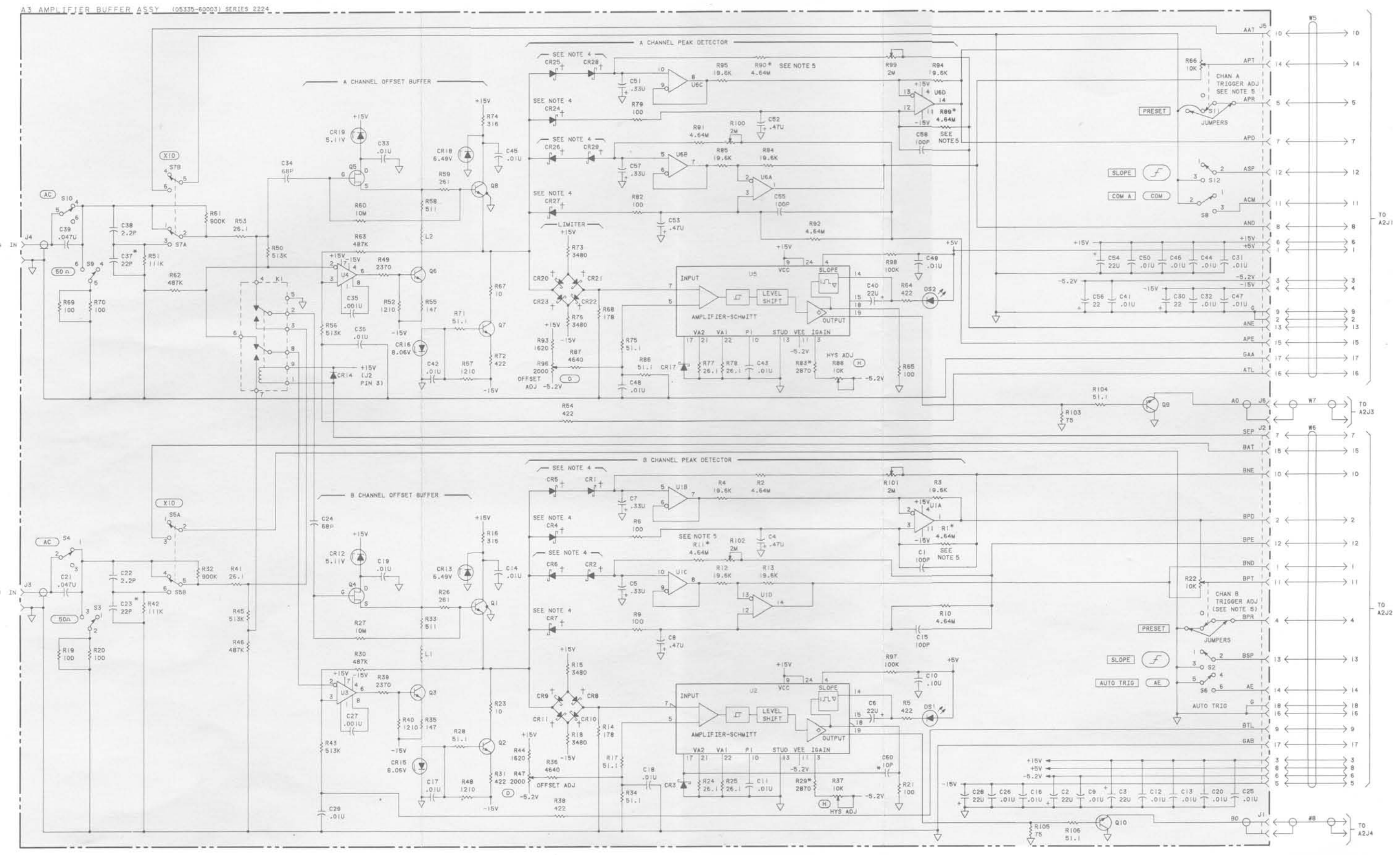
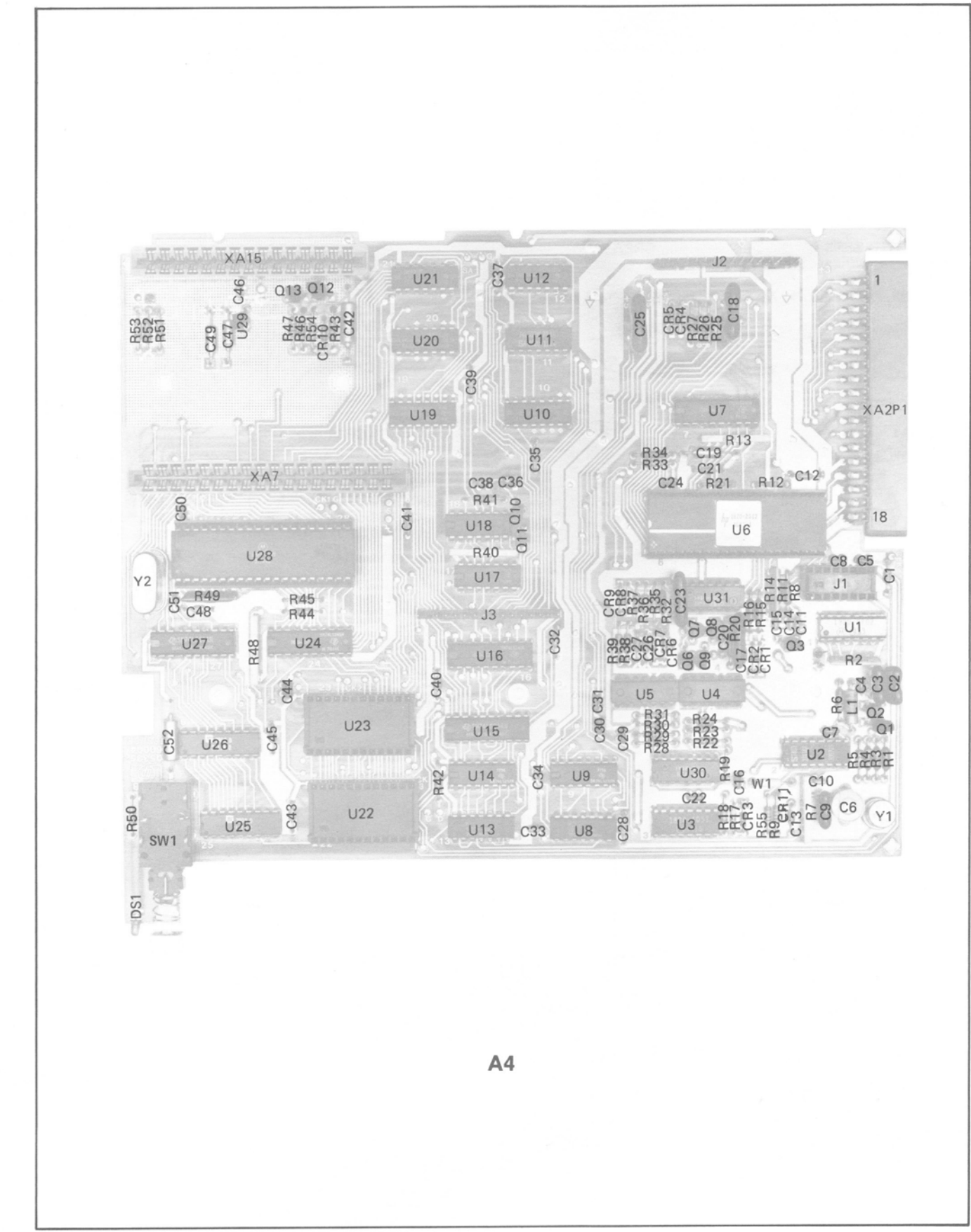

Figure 8-109. A3 Amplifier Buffer Assembly

Figure 8-109
A3 AMPLIFIER BUFFER ASSEMBLY
(See Page 8-109)



Part of Figure 8-110. A4 Main Logic Assembly

NOTES

- REFERENCE DESIGNATIONS WITHIN THIS ASSEMBLY ARE ABBREVIATED. ADD ASSEMBLY NUMBER TO ABBREVIATION FOR A COMPLETE REFERENCE DESIGNATION.
- UNLESS OTHERWISE INDICATED: RESISTANCE IN OHMS CAPACITANCE IN FARADS INDUCTANCE IN HENRIES
- ASTERISK (*) INDICATES FACTORY SELECTED COMPONENT VALUE. AVERAGE VALUE SHOWN. PART MAY NOT BE IN ALL INSTRUMENTS.
- WHEN TEST POINTS "D" AND "G" ARE SHORTED TOGETHER, DIAGNOSTIC 17 IS INVOKED.
- JUMPER W1 MUST BE REMOVED WHEN OVEN OSCILLATOR (OPTION 010) IS INSTALLED.

CONNECTOR PIN TABLES:

| A4-A1 CONNECTIONS | | |
|-------------------|------|--------------------------|
| A4J2 | A1J1 | DESCRIPTION |
| 1 | 1 | GROUND (Clean) |
| 2 | 2 | N.C. (Key) |
| 3 | 3 | -5.2 Volts |
| 4 | 4 | GROUND (Clean) |
| 5 | 5 | +3 Volts |
| 6 | 6 | +15 Volts |
| 7 | 7 | GROUND |
| 8 | 8 | -15 Volts |
| 9 | 9 | GROUND |
| 10 | 10 | GROUND |
| 11 | 11 | +5 Volts |
| 12 | 12 | +5 Volts |
| 13 | 13 | +5 Volts |
| 14 | 14 | +5 Volts |
| 15 | 15 | +24 Volts (to Osc) |
| 16 | 16 | +24 Volts - Power Switch |

| A4-A2 CONNECTIONS* | | |
|--------------------|------|-----------------|
| A4XA2P1 | A2P1 | DESCRIPTION |
| (1) | (1) | LAOE |
| (2) | (2) | R/W (not used) |
| (3) | (3) | A5 (not used) |
| (4) | (4) | A4 (not used) |
| (5) | (5) | A3 |
| (6) | (6) | D7 |
| (7) | (7) | D5 |
| (8) | (8) | D1 |
| (9) | (9) | D3 |
| (10) | (10) | BTL |
| (11) | (11) | NC |
| (12) | (12) | ATL |
| (13) | (13) | NC |
| (14) | (14) | +3 Volts |
| (15) | (15) | CH B to MRC |
| (16) | (16) | +3 Volts |
| (17) | (17) | CH A to MRC |
| (18) | (18) | +3 Volts |
| (1) | (1) | L/VMAE |
| (2) | (2) | LBOE (not used) |
| (3) | (3) | A2 |
| (4) | (4) | A1 |
| (5) | (5) | A0 |
| (6) | (6) | D6 |
| (7) | (7) | D4 |
| (8) | (8) | D2 |
| (9) | (9) | D0 |
| (10) | (10) | GROUND |
| (11) | (11) | NC |
| (12) | (12) | NC |
| (13) | (13) | NC |
| (14) | (14) | +3 Volts |
| (15) | (15) | +3 Volts |
| (16) | (16) | +3 Volts |
| (17) | (17) | +3 Volts |
| (18) | (18) | +3 Volts |

*See A11 Schematic for A4-A11 connections.

A4 ACTIVE COMPONENTS

| REFERENCE | HP PART NO. |
|---------------------|--------------|
| A4CR1, CR2, CR4-CR9 | 1901-0050 |
| A4CR3, CR10, CR11 | 1901-0535 |
| A4DS1 | 1990-0627 |
| A4Q1-Q3, Q10 | 1854-0215 |
| A4Q4, Q5 | NOT ASSIGNED |
| A4Q6-Q9 | 1853-0015 |
| A4U1 | 1820-0802 |
| A4U2 | 1820-0810 |
| A4U3 | 1820-1052 |
| A4U4, U5 | 1820-0210 |
| A4U6 | 1820-2075 |
| A4U7 | 1820-1989 |
| A4U8, U13 | 1820-1438 |
| A4U9, U14 | 1820-1281 |
| A4U10 | 1820-1144 |
| A4U11 | 1820-1416 |
| A4U12 | 1820-2024 |
| A4U15, U27 | 1820-2866 |
| A4U16, U24 | 1820-1112 |
| A4U17, U18 | 1820-1240 |
| A4U19 | 1820-1202 |
| A4U20 | 1820-1197 |
| A4U21 | 1818-1249 |
| A4U22 | 1818-1250 |
| A4U23 | 1818-0381 |
| A4U25, U26 | 1820-2099 |
| A4U28 | 1826-0275 |
| A4U29 | 1858-0040 |
| A4U30 | 1858-0063 |
| A4U31 | 0410-0423 |
| A4Y1 | 0410-0465 |
| A4Y2 | |

NOTES

CONNECTOR PIN TABLES (CONTINUED):

| A4-A5 CONNECTIONS | | |
|-------------------|------|---------------------------|
| A4J3 | A5P2 | DESCRIPTION |
| 1 | 1 | GROUND (Clean) |
| 2 | 2 | N.C. (Key) |
| 3 | 3 | Data Line 5 |
| 4 | 4 | Data Line 4 |
| 5 | 5 | Data Line 7 |
| 6 | 6 | Data Line 6 |
| 7 | 7 | Data Line 0 |
| 8 | 8 | Data Line 3 |
| 9 | 9 | Data Line 1 |
| 10 | 10 | Data Line 2 |
| 11 | 11 | MTN |
| 12 | 12 | KB IRQ |
| 13 | 13 | E2 (Key/Display Control) |
| 14 | 14 | E1 (Key/Display Data Out) |
| 15 | 15 | E0 (Keyboard Status) |
| 16 | 16 | +5V |

| A4-A7 CONNECTIONS | | | | | |
|-------------------|------|-------------|-------|------|-------------|
| A4XA7 | A7P1 | DESCRIPTION | A4XA7 | A7P1 | DESCRIPTION |
| 1 | 1 | A1 | 1 | 1 | A0 |
| 2 | 2 | A3 | 2 | 2 | A2 |
| 3 | 3 | A5 | 3 | 3 | A4 |
| 4 | 4 | A7 | 4 | 4 | A6 |
| 5 | 5 | A9 | 5 | 5 | A8 |
| 6 | 6 | A11 | 6 | 6 | A10 |
| 7 | 7 | A13 | 7 | 7 | A12 |
| 8 | 8 | Reset | 8 | 8 | A14 |
| 9 | 9 | E (1 MHz) | 9 | 9 | NMI |
| 10 | 10 | IRQ | 10 | 10 | RAM Enable |
| 11 | 11 | VMA-E | 11 | 11 | VMA-E |
| 12 | 12 | R/W | 12 | 12 | A15 |
| 13 | 13 | GROUND | 13 | 13 | GROUND |
| 14 | 14 | +5V | 14 | 14 | -5.2V |
| 15 | 15 | D1 | 15 | 15 | D0 |
| 16 | 16 | D3 | 16 | 16 | D2 |
| 17 | 17 | D5 | 17 | 17 | D4 |
| 18 | 18 | D7 | 18 | 18 | D6 |

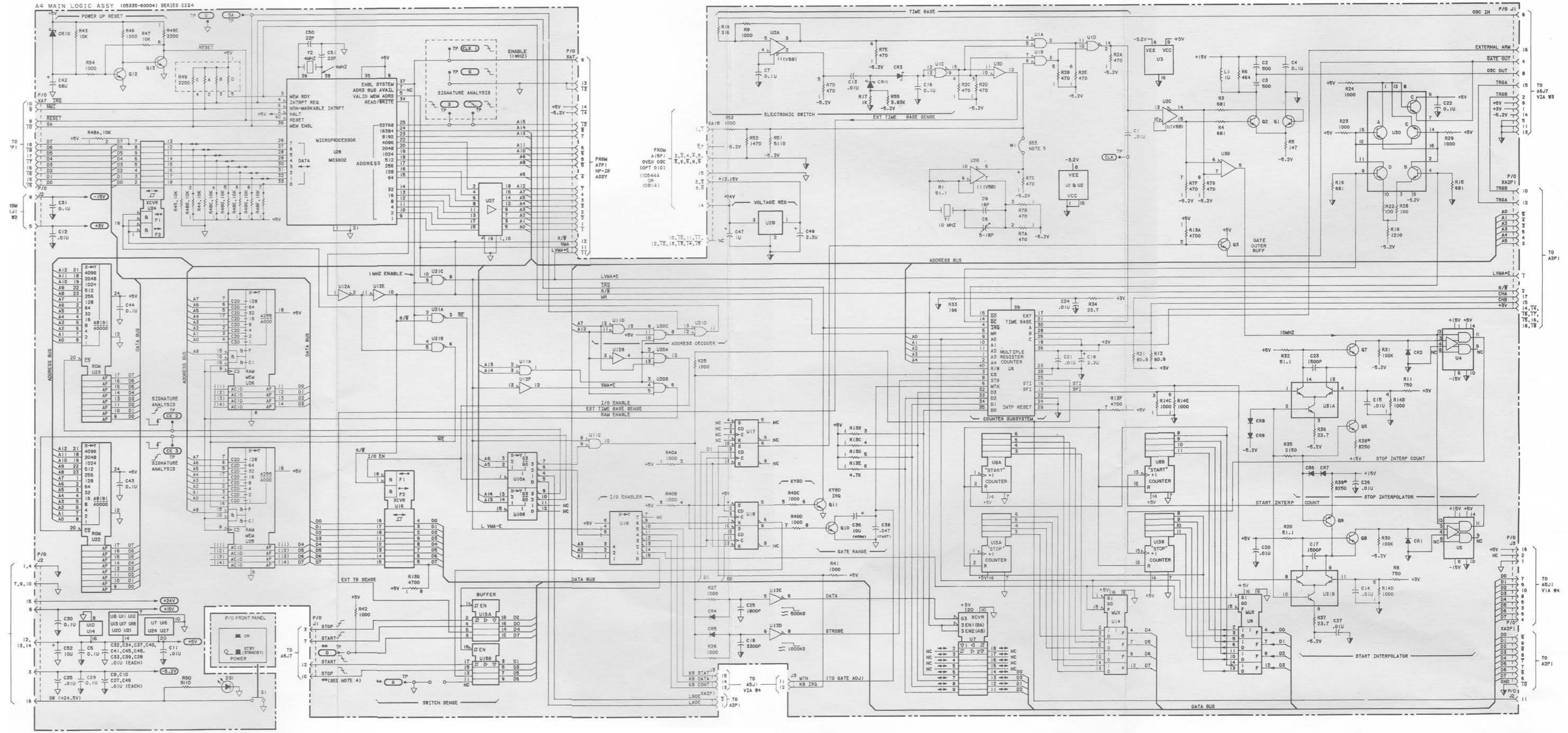
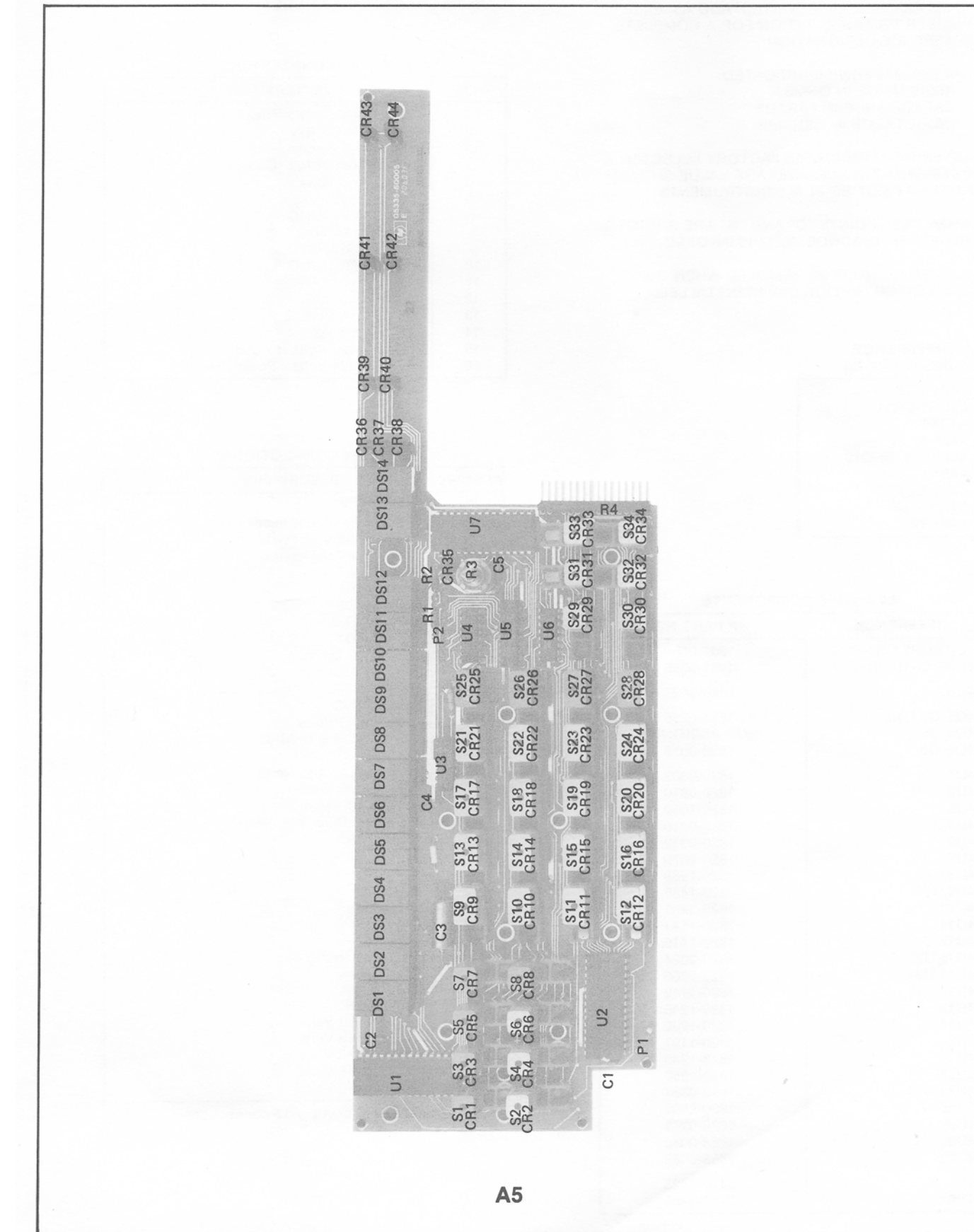

Figure 8-110. A4 Main Logic Assembly

Figure 8-110
A4 MAIN LOGIC ASSEMBLY
(See Page 8-111)



A5

Part of Figure 8-111. A5 Keyboard and Display Assembly

NOTES

1. REFERENCE DESIGNATIONS WITHIN THIS ASSEMBLY ARE ABBREVIATED. ADD ASSEMBLY NUMBER TO ABBREVIATION FOR A COMPLETE REFERENCE DESIGNATION.
2. UNLESS OTHERWISE INDICATED:
RESISTANCE IN OHMS
CAPACITANCE IN FARADS
INDUCTANCE IN HENRIES
3. ASTERISK (*) INDICATES FACTORY SELECTED COMPONENT VALUE. AVERAGE VALUE SHOWN. PART MAY NOT BE IN ALL INSTRUMENTS.

**A5
REFERENCE
DESIGNATORS**

- A5C2-C6
- A5DS1-DS58
- A5J1,J2
- A5R1-R5
- A5S1-S34
- A5U1-U7
- A5W1

A5 ACTIVE COMPONENTS

| REFERENCE | HP PART NO. |
|-----------------|-------------|
| A5DS1-DS12,DS14 | 1990-0574 |
| A5DS13 | 1990-0681 |
| A5DS15-DS48 | 1990-0851 |
| A5DS49-DS58 | 1990-0486 |
| A5U1,U2,U7 | 1820-2132 |
| A5U3 | 1820-1207 |
| A5U4 | 1820-1195 |
| A5U5 | 1820-1858 |
| A5U6 | 1820-1641 |

CONNECTOR PIN TABLES:

A5-A4 CONNECTIONS

| A5P2 | A4J3 | DESCRIPTION |
|------|------|---------------------------------------|
| 1 | 1 | GROUND (Clean) |
| 2 | 2 | N.C. (Key) |
| 3 | 3 | Data Line 5 |
| 4 | 4 | Data Line 7 |
| 5 | 5 | Data Line 4 |
| 6 | 6 | Data Line 6 |
| 7 | 7 | Data Line 0 |
| 8 | 8 | Data Line 3 |
| 9 | 9 | Data Line 1 |
| 10 | 10 | Data Line 2 |
| 11 | 11 | MTN |
| 12 | 12 | KB IRQ |
| 13 | 13 | E ₂ (Key/Display Control) |
| 14 | 14 | E ₁ (Key/Display Data Out) |
| 15 | 15 | E ₀ (Keyboard Status) |
| 16 | 16 | +5V |

A5-A10 CONNECTIONS

| A5J2 | A10J1 | DESCRIPTION |
|------|-------|-------------|
| (1) | (1) | D6 |
| (2) | (2) | N/C |
| (3) | (3) | D7 |
| (4) | (4) | A5U2(2) |
| (5) | (5) | A5U2(26) |
| (6) | (6) | A5U2(4) |
| (7) | (7) | A5U2(24) |
| (8) | (8) | A5U2(20) |
| (9) | (9) | A5U2(21) |
| (10) | (10) | A5U2(22) |
| (11) | (11) | A5U3(1) |
| (12) | (12) | A5U3(4) |
| (13) | (13) | A5U3(6) |
| (14) | (14) | A5U3(2) |
| (15) | (15) | A5U3(3) |
| (16) | (16) | A5U3(5) |

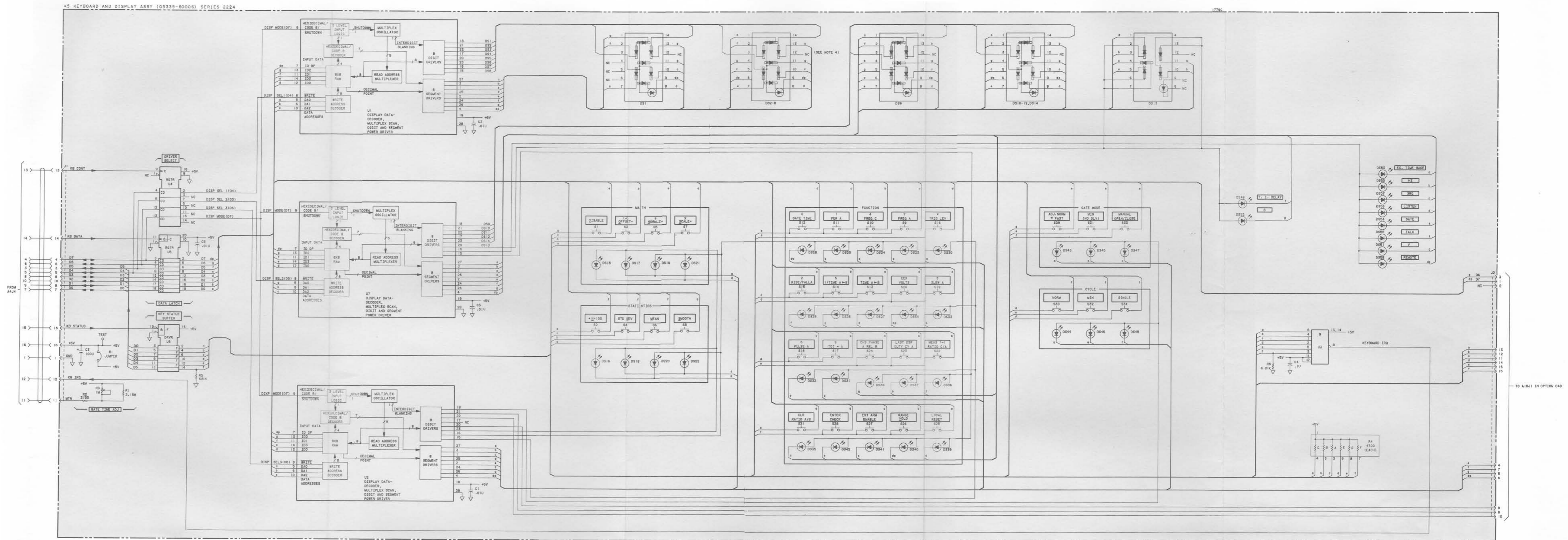
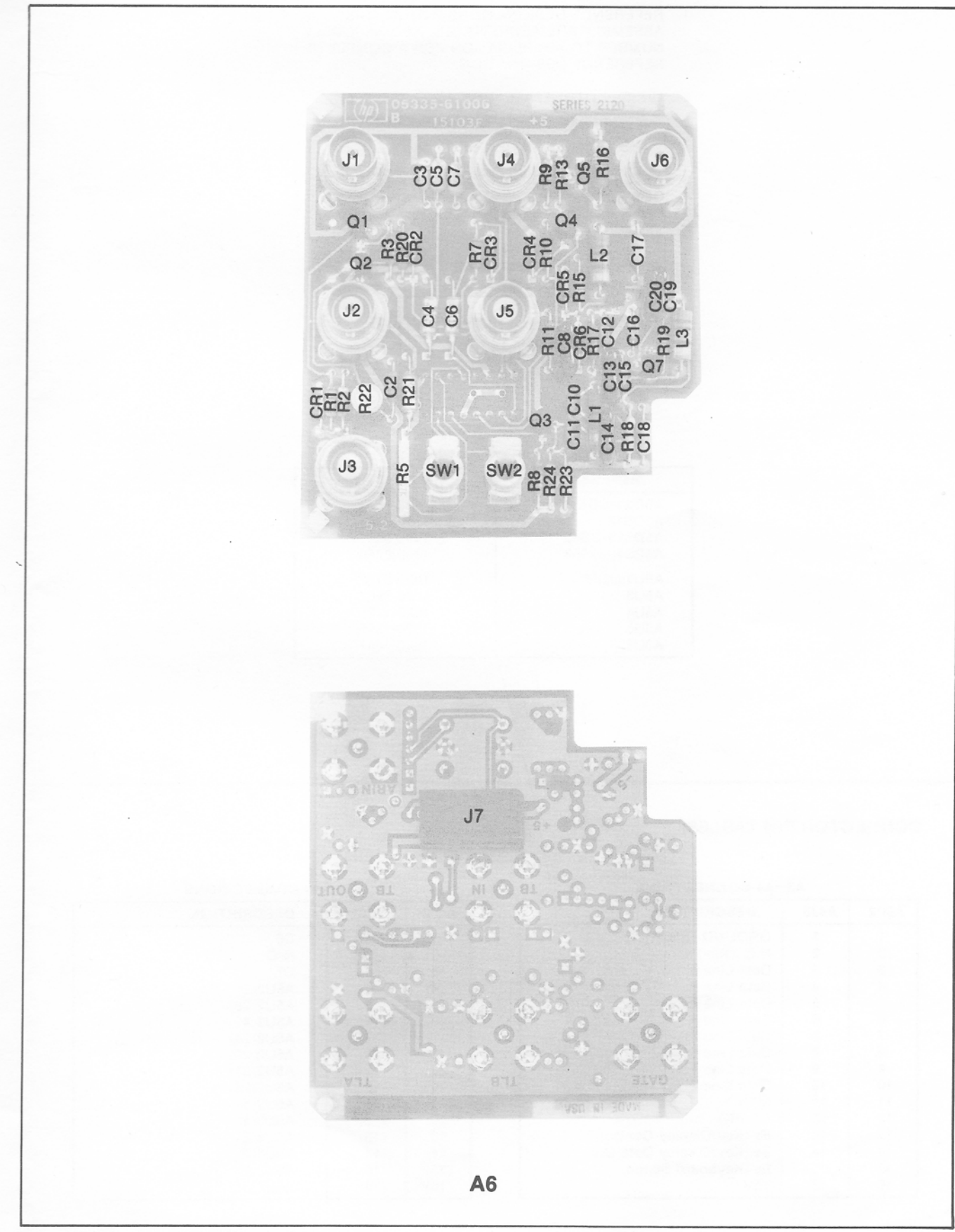

Figure 8-111. A5 Keyboard and Display Assembly

Figure 8-111
A5 KEYBOARD AND DISPLAY ASSEMBLY
(See Page 8-113)



A6

Part of Figure 8-112. A6 Rear Panel Assembly

NOTES

1. REFERENCE DESIGNATIONS WITHIN THIS ASSEMBLY ARE ABBREVIATED. ADD ASSEMBLY NUMBER TO ABBREVIATION FOR A COMPLETE REFERENCE DESIGNATION.
2. UNLESS OTHERWISE INDICATED:
RESISTANCE IN OHMS
CAPACITANCE IN FARADS
INDUCTANCE IN HENRIES
3. ASTERISK (*) INDICATES FACTORY SELECTED COMPONENT VALUE. AVERAGE VALUE SHOWN. PART MAY NOT BE IN ALL INSTRUMENTS.
4. S1 AND S2 ARE SPDT CENTER-OFF TOGGLE SWITCHES.

**A6
REFERENCE
DESIGNATORS**

| |
|---------------|
| A6C1-C20 |
| A6CR1-CR6 |
| A6J1-J7 |
| A6L1-L3 |
| A6Q1-Q7 |
| A6R1-R3,R5 |
| A6R7-R11, R13 |
| A6R15-R24 |
| A6S1,S2 |

A6 ACTIVE COMPONENTS

| REFERENCE | HP PART NO. |
|---------------|-------------|
| A6CR1,CR3-CR6 | 1901-0050 |
| A6CR2 | 1901-0535 |
| A6Q1-Q3,Q5-Q7 | 1854-0215 |
| A6Q4 | 1854-0036 |

CONNECTOR PIN TABLES:

A6-A4 CONNECTIONS

| A6J1 | A4J7 | DESCRIPTION |
|------|------|-------------------------|
| 1 | 1 | +3 |
| 2 | 2 | TLB (Trigger Level B) |
| 3 | 3 | Stop |
| 4 | 4 | Gate Output |
| 5 | 5 | GND (clean) |
| 6 | 6 | Ext Time Base Ins |
| 7 | 7 | Start |
| 8 | 8 | Osc Out (Time Base Out) |
| 9 | 9 | +5V |
| 10 | 10 | Stop |
| 11 | 11 | Ground (clean) |
| 12 | 12 | Start |
| 13 | 13 | Ground (clean) |
| 14 | 14 | -5.2V |
| 15 | 15 | TLA (Trigger Level A) |
| 16 | 16 | Ext Arm (to MRC) |

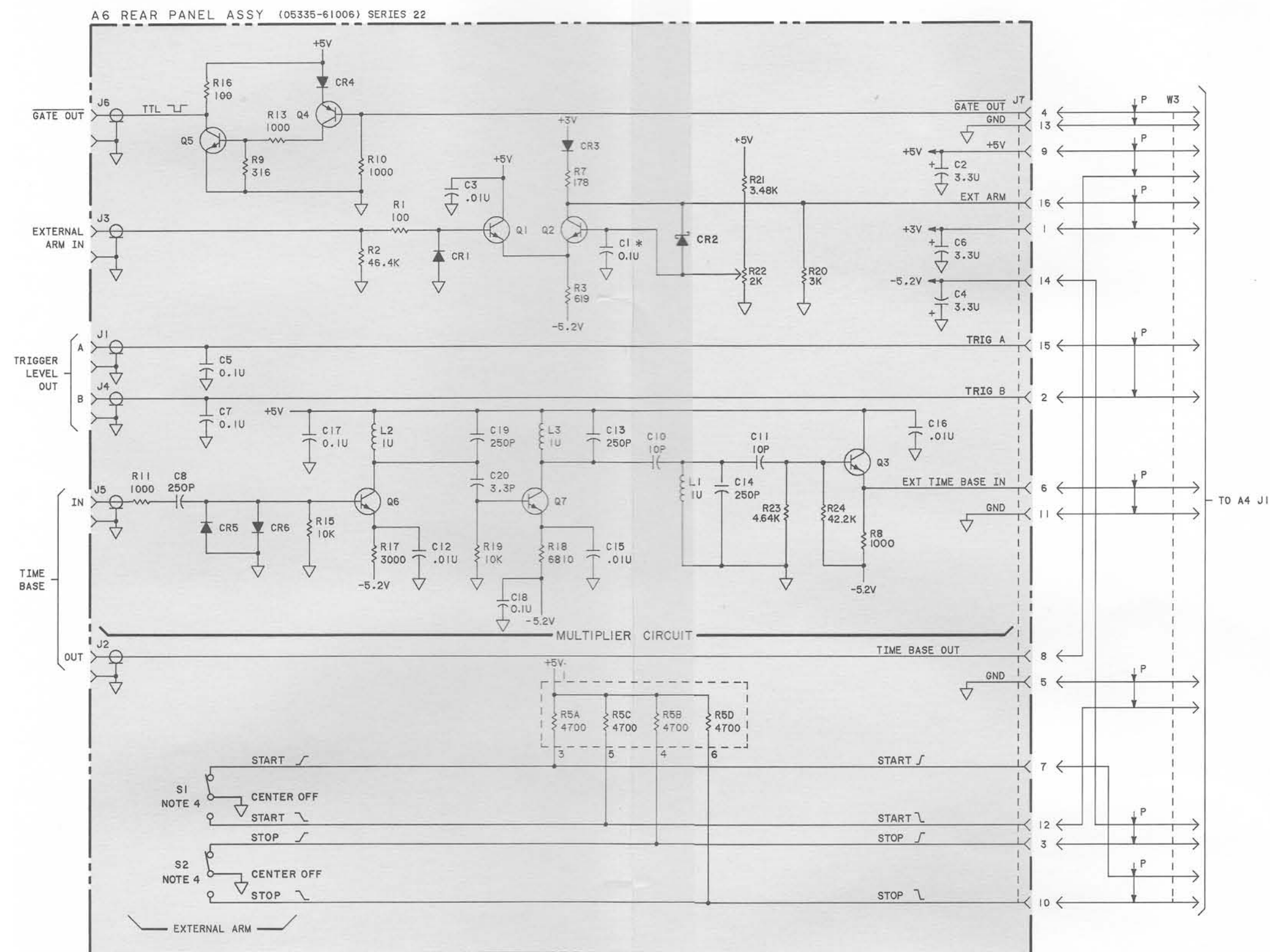
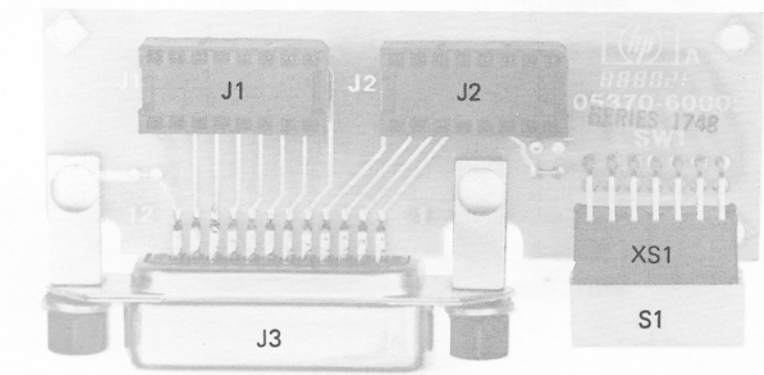
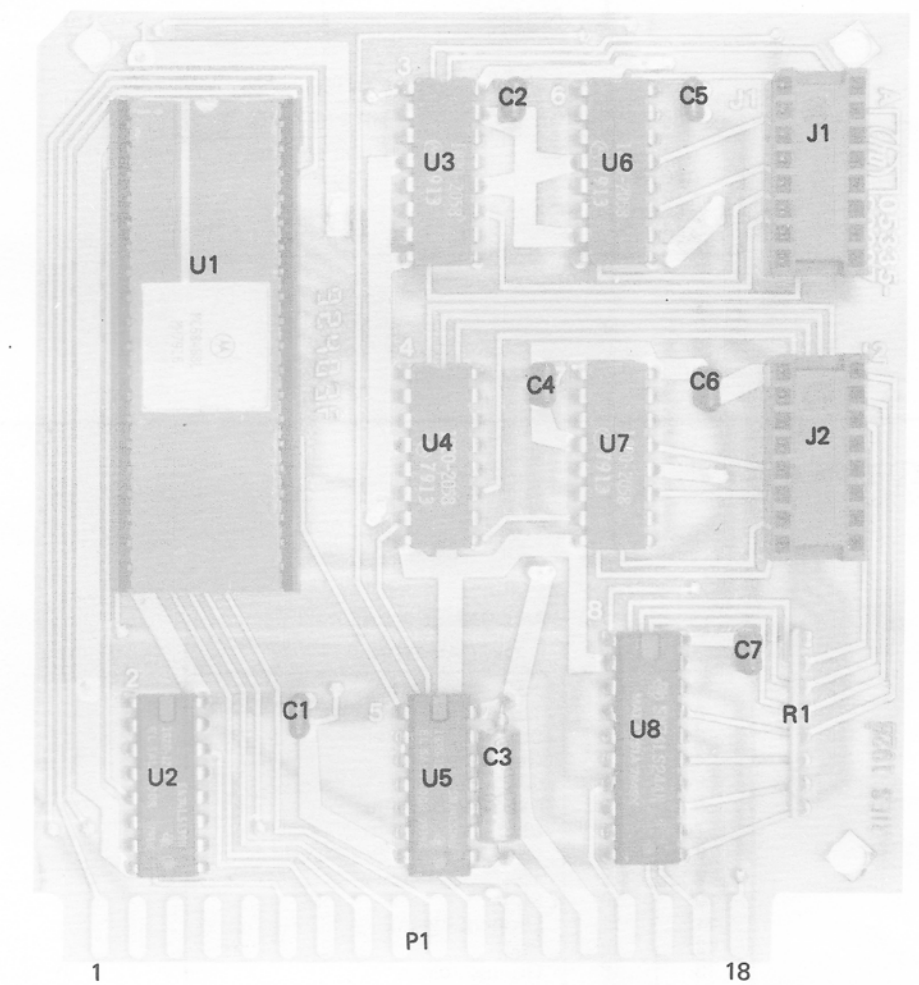

Figure 8-112. A6 Rear Panel Assembly



A14



A7

Part of Figure 8-113. A7 HP-IB Logic and A14 HP-IB Connector Assembly

Figure 8-112
A6 REAR PANEL ASSEMBLY

(See Page 8-115)

NOTES

1. REFERENCE DESIGNATIONS WITHIN THIS ASSEMBLY ARE ABBREVIATED. ADD ASSEMBLY NUMBER TO ABBREVIATION FOR A COMPLETE REFERENCE DESIGNATION.
2. UNLESS OTHERWISE INDICATED:
RESISTANCE IN OHMS
CAPACITANCE IN FARADS
INDUCTANCE IN HENRIES
3. ASTERISK (*) INDICATES FACTORY SELECTED COMPONENT VALUE. AVERAGE VALUE SHOWN. PART MAY NOT BE IN ALL INSTRUMENTS.
4. WHEN CONNECTED, PROVIDES SA STIMULUS MODE (SAME AS DIAG. 02); A14S1A6 MUST BE IN "1" POSITION.

**A7
REFERENCE
DESIGNATORS**

A7C1-C6
A7J1,J2
A7R1
A7U1-U8

A7 ACTIVE COMPONENTS

| REFERENCE | HP PART NO. |
|---------------|-------------|
| A7U1 | 1820-2219 |
| A7U2 | 1820-1281 |
| A7U3,U4,U6,U7 | 1820-2058 |
| A7U5 | 1820-1199 |
| A7U8 | 1820-2024 |

**A14 HP-IB
CONNECTOR BOARD
REFERENCE
DESIGNATORS**

A14J1-J3
A14S1
A14XS1

NOTES

CONNECTOR PIN TABLES:

HP-IB CONNECTIONS (A4/A7)

| A4XA7 | A7P1 | DESCRIPTION | A4XA7 | A7P1 | DESCRIPTION |
|-------|------|-------------|-------|------|-------------|
| 1 | 1 | A1 | 1 | 1 | A0 |
| 2 | 2 | A3 | 2 | 2 | A2 |
| 3 | 3 | A5 | 3 | 3 | A4 |
| 4 | 4 | A7 | 4 | 4 | A6 |
| 5 | 5 | A9 | 5 | 5 | A8 |
| 6 | 6 | A11 | 6 | 6 | A10 |
| 7 | 7 | A13 | 7 | 7 | A12 |
| 8 | 8 | Reset | 8 | 8 | A14 |
| 9 | 9 | E (1 MHz) | 9 | 9 | NMI |
| 10 | 10 | IRQ | 10 | 10 | RAM ENABLE |
| 11 | 11 | VMA | 11 | 11 | VMA-E |
| 12 | 12 | R/W | 12 | 12 | A15 |
| 13 | 13 | Ground | 13 | 13 | Ground |
| 14 | 14 | +5V | 14 | 14 | -5.2V |
| 15 | 15 | D1 | 15 | 15 | D0 |
| 16 | 16 | D3 | 16 | 16 | D2 |
| 17 | 17 | D5 | 17 | 17 | D4 |
| 18 | 18 | D7 | 18 | 18 | D6 |

HP-IB CONNECTIONS A7/A14

| A7J1 | A14J1 | DESCRIPTION | A7J2 | A14J2 | DESCRIPTION |
|------|-------|-------------|------|-------|-------------|
| 1 | 1 | EO1 | 1 | 1 | Ground |
| 2 | 2 | DAV | 2 | 2 | A1 |
| 3 | 3 | RFD | 3 | 3 | A2 |
| 4 | 4 | DAC | 4 | 4 | A3 |
| 5 | 5 | IFC | 5 | 5 | DIO1 |
| 6 | 6 | SRQ | 6 | 6 | DIO2 |
| 7 | 7 | ATN | 7 | 7 | DIO3 |
| 8 | 8 | N.C. | 8 | 8 | DIO4 |
| 9 | 9 | Ground | 9 | 9 | DIO8 |
| 10 | 10 | Ground | 10 | 10 | DIO7 |
| 11 | 11 | Ground | 11 | 11 | DIO6 |
| 12 | 12 | Ground | 12 | 12 | DIO5 |
| 13 | 13 | Ground | 13 | 13 | A7 (Talk) |
| 14 | 14 | Ground | 14 | 14 | A6 (Listen) |
| 15 | 15 | Ground | 15 | 15 | A5 |
| 16 | 16 | REN | 16 | 16 | A4 |

HP-IB INTERFACE CONNECTOR SIGNALS

| HP-IB Pin | Connectors Signals |
|-----------|------------------------------|
| 1 | DIO1 |
| 2 | DIO2 |
| 3 | DIO3 |
| 4 | DIO4 |
| 5 | EO1 |
| 6 | DAV |
| 7 | NRFD |
| 8 | NDAC |
| 9 | IFC |
| 10 | SRQ |
| 11 | ATN |
| 12 | SHIELD CHASSIS GROUND |
| 13 | DIO5 |
| 14 | DIO6 |
| 15 | DIO7 |
| 16 | DIO8 |
| 17 | REN |
| 18 | P/O Twisted Pair with Pin 6 |
| 19 | P/O Twisted Pair with Pin 7 |
| 20 | P/O Twisted Pair with Pin 8 |
| 21 | P/O Twisted pair with Pin 9 |
| 22 | P/O Twisted Pair with Pin 10 |
| 23 | P/O Twisted Pair with Pin 11 |
| 24 | ISOLATED DIGITAL GROUND |

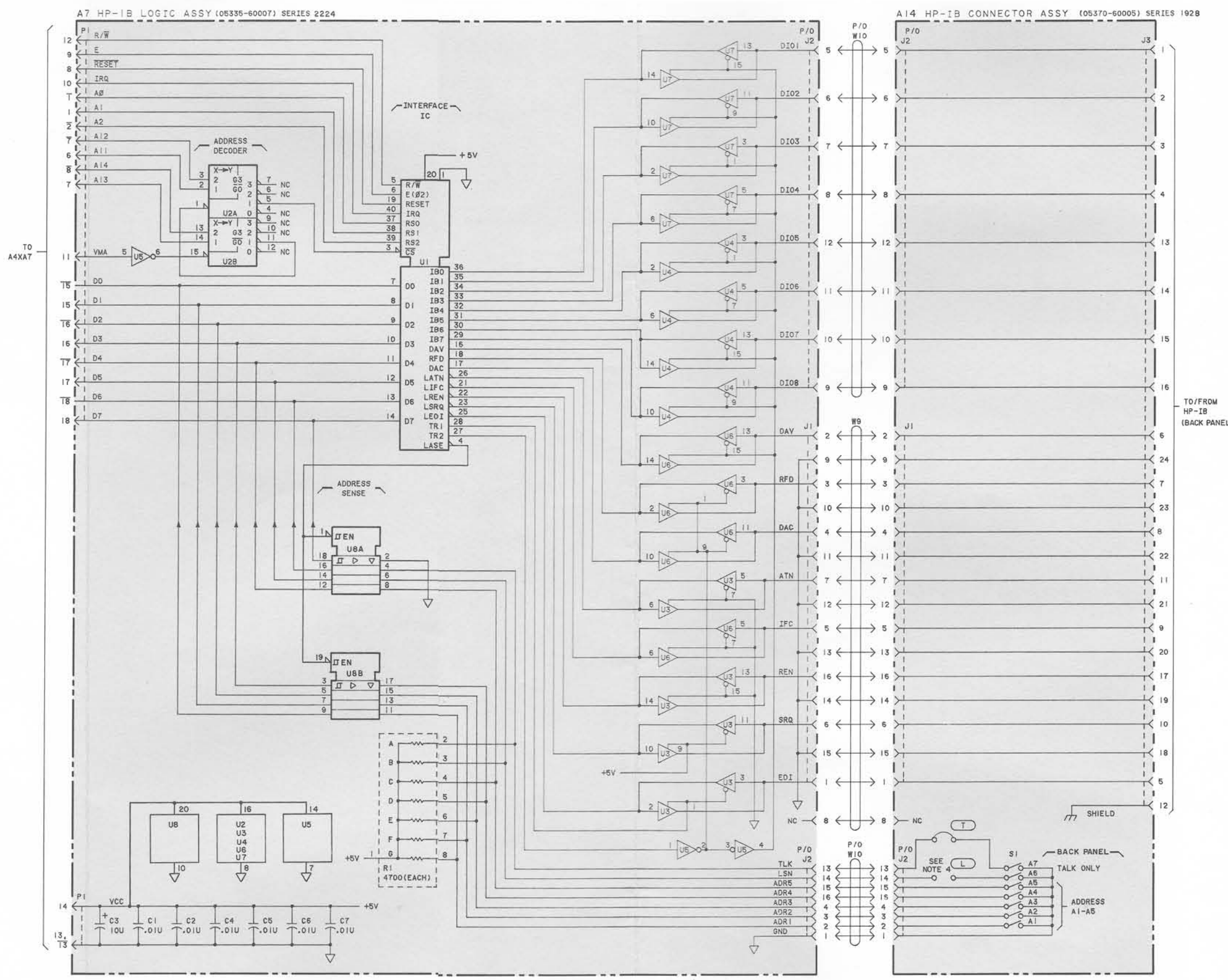

Figure 8-113. A7 HP-IB Logic Assembly and A14 HP-IB Connector Assembly

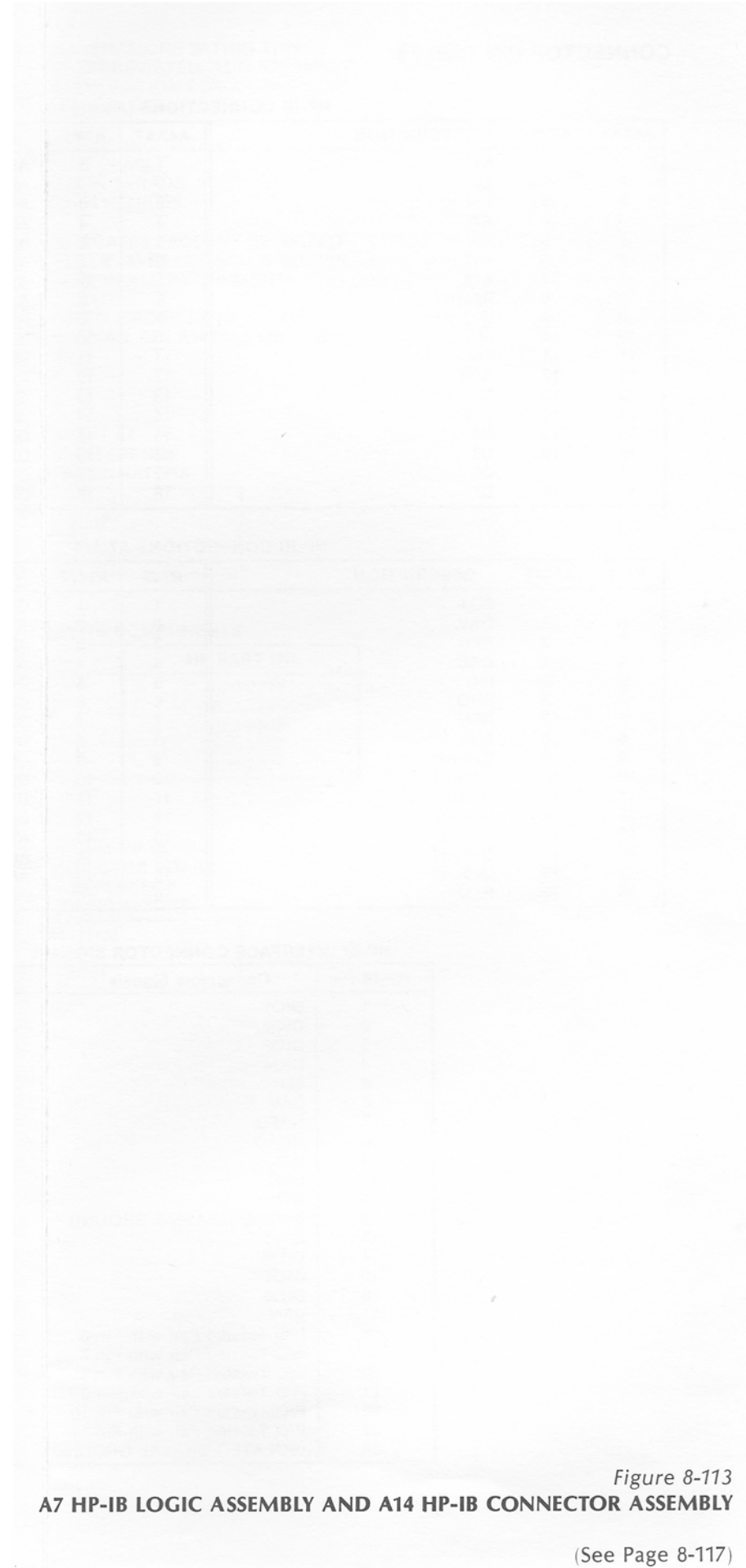
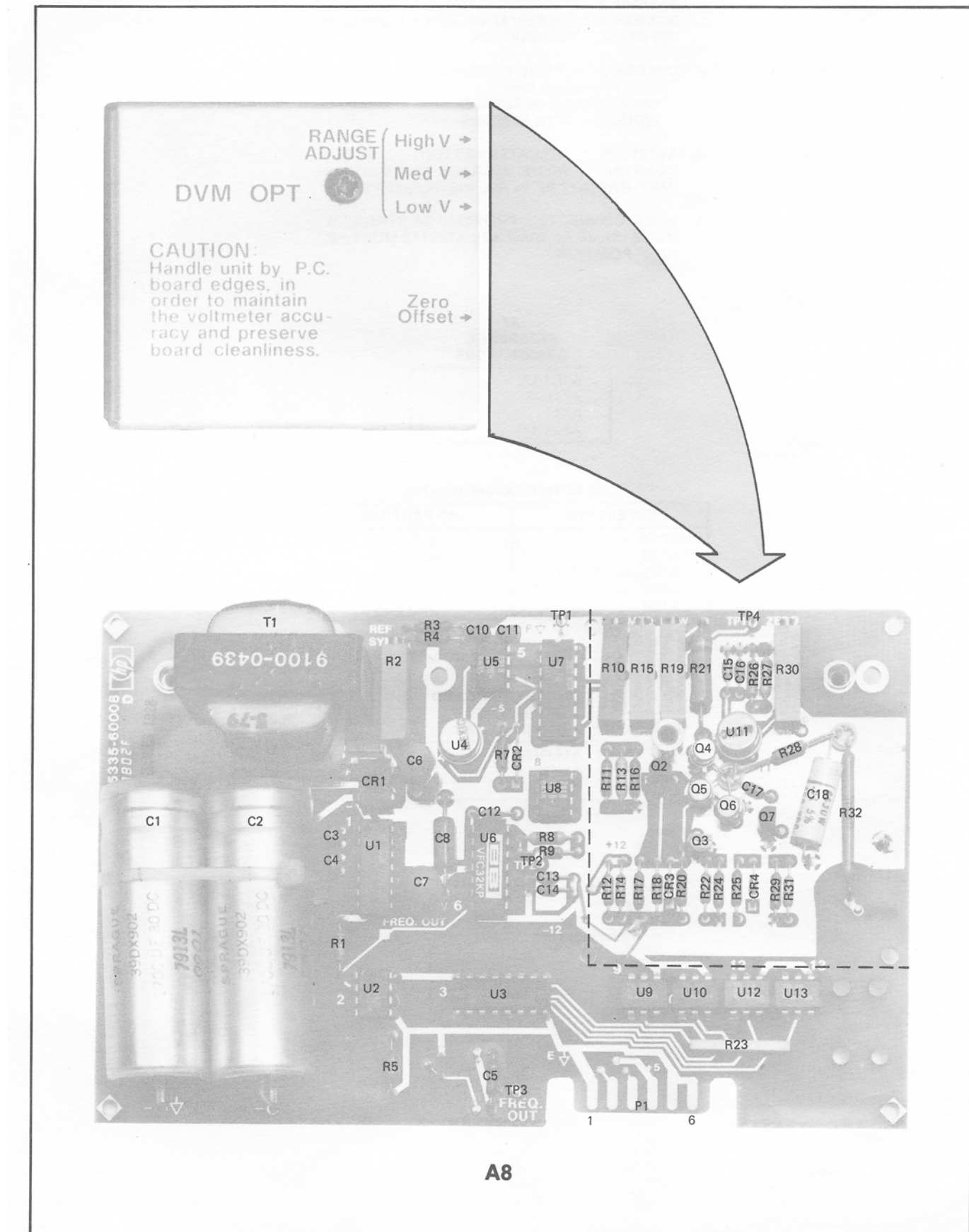

Figure 8-113
A7 HP-IB LOGIC ASSEMBLY AND A14 HP-IB CONNECTOR ASSEMBLY

(See Page 8-117)



Part of Figure 8-114. A8 Digital Voltmeter (Option 020) Assembly

NOTES

1. REFERENCE DESIGNATIONS WITHIN THIS ASSEMBLY ARE ABBREVIATED. ADD ASSEMBLY NUMBER TO ABBREVIATION FOR A COMPLETE REFERENCE DESIGNATION.
2. UNLESS OTHERWISE INDICATED:
RESISTANCE IN OHMS
CAPACITANCE IN FARADS
INDUCTANCE IN HENRIES
3. ASTERISK (*) INDICATES FACTORY SELECTED COMPONENT VALUE. AVERAGE VALUE SHOWN. PART MAY NOT BE IN ALL INSTRUMENTS.
4. ∇ E CHASSIS COMMON
 ∇ F FLOATING COMMON
 ∇ G INSTRUMENT COMMON (NOISE FREE).

A8 REFERENCE DESIGNATORS

- A8C1-C8, C10-C18
- A8CR1-CR4
- A8Q2-Q7
- A8R1-R32
- A8TP1-TP4
- A8U1-U13

A8 OPTION 020 DVM ACTIVE COMPONENTS

| REFERENCE | HP PART NO. |
|---------------------|-------------|
| A8CR1 | 1906-0069 |
| A8CR2 | 1901-0033 |
| A8CR3, CR4 | 1901-0050 |
| A8Q2 | 1854-0215 |
| A8Q3, Q7 | 1853-0036 |
| A8Q4-Q6 | 1855-0368 |
| A8U1 | 1826-0625 |
| A8U2 | 1990-0429 |
| A8U3 | 1820-1195 |
| A8U4 | 1826-0650 |
| A8U5, U8 | 1826-0635 |
| A8U6 | 1826-0624 |
| A8U7 | 1826-0610 |
| A8U9, U10, U12, U13 | 1990-0543 |
| A8U11 | 1826-0627 |

CONNECTOR PIN TABLES:

A8-A2 CONNECTIONS

| A8P1 | A2XA8 | DESCRIPTION |
|------|-------|-----------------------|
| 1 | 1 | GROUND |
| 2 | 2 | AC Supply (18.5V rms) |
| 3 | 3 | Enable |
| 4 | 4 | +5 Volts |
| 5 | 5 | Ground (Option 1N) |
| 6 | 6 | Ground |
| 1 | 1 | DVM Output (Freq) |
| 2 | 2 | AC Supply (18.5V rms) |
| 3 | 3 | Data Line 5 |
| 4 | 4 | Data Line 6 |
| 5 | 5 | Data Line 7 |
| 6 | 6 | Data Line 4 |

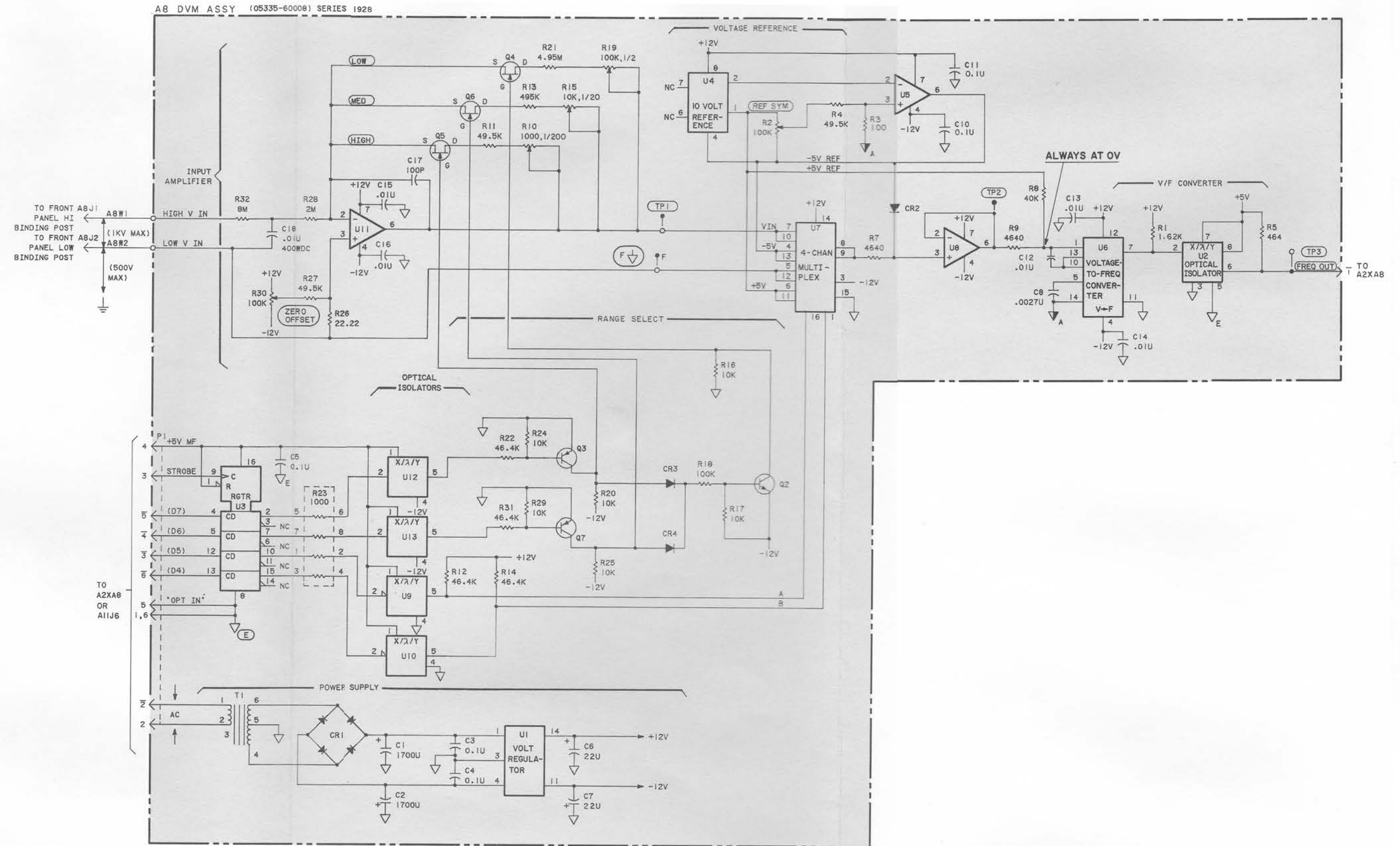
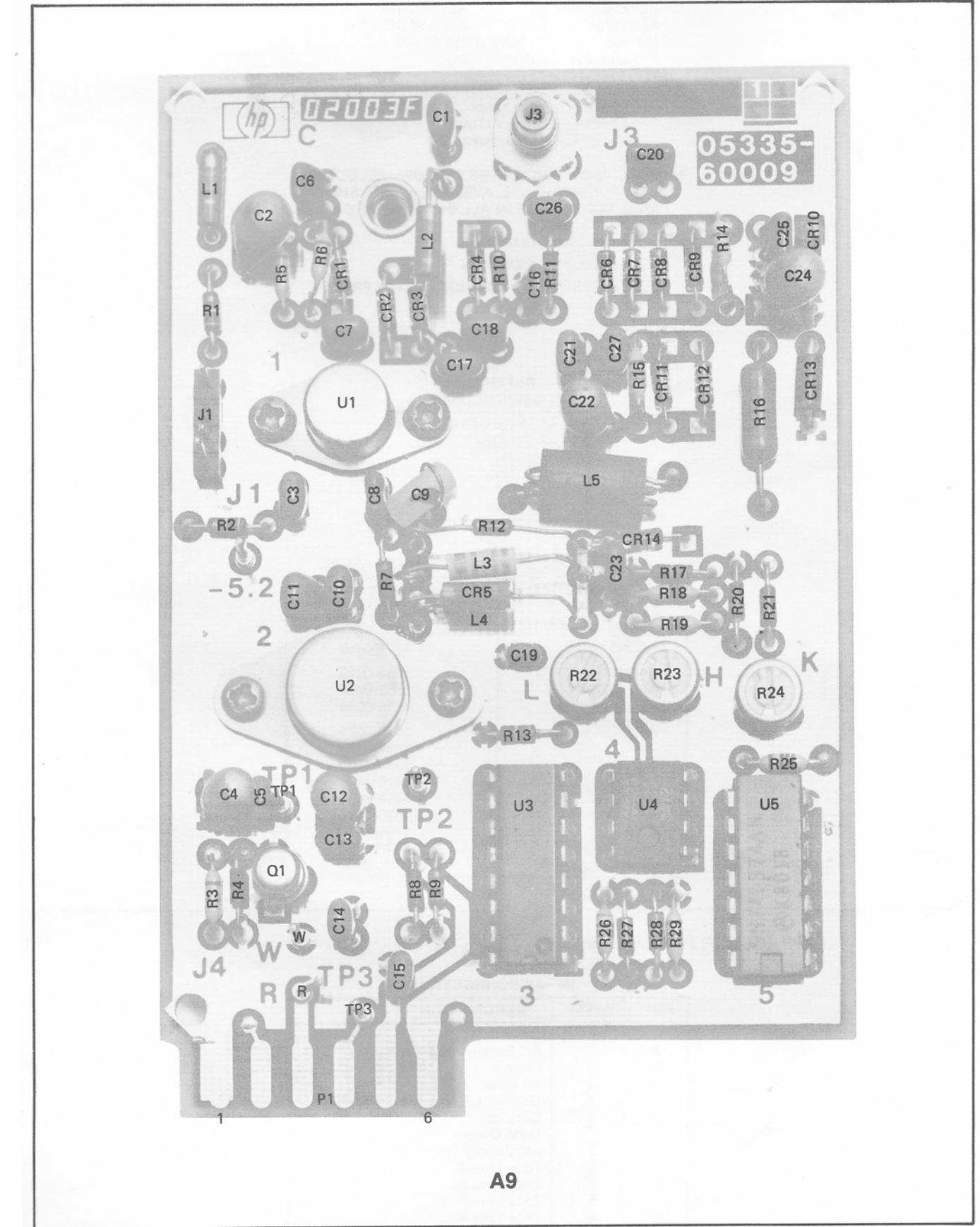

Figure 8-114. A8 Digital Voltmeter (Option 020) Assembly



A9

Part of Figure 8-115. A9 Channel C (Option 030) Assembly

Figure 8-114
A8 DIGITAL VOLTMETER (OPTION 020) ASSEMBLY

(See Page 8-119)

NOTES

1. REFERENCE DESIGNATIONS WITHIN THIS ASSEMBLY ARE ABBREVIATED. ADD ASSEMBLY NUMBER TO ABBREVIATION FOR A COMPLETE REFERENCE DESIGNATION.
2. UNLESS OTHERWISE INDICATED:
RESISTANCE IN OHMS
CAPACITANCE IN FARADS
INDUCTANCE IN HENRIES
3. ASTERISK (*) INDICATES FACTORY SELECTED COMPONENT VALUE. AVERAGE VALUE SHOWN. PART MAY NOT BE IN ALL INSTRUMENTS.
4. CR5 AND CR14 MATCHED SET OF DIODES (P/N 05335-80005).

A9 REFERENCE DESIGNATORS

- A9C1-C28
- A9CR1-CR14
- A9J1-J3
- A9Q1
- A9R1-R29
- A9U1-U5
- A9W1,W2
- A9W2R1
- A9W3
- A9W3J2

A9 OPTION 030 "C" CHANNEL ACTIVE COMPONENTS

| REFERENCE | HP PART NO. |
|---------------------|-------------|
| A9CR1-CR4 | 1901-0639 |
| A9CR5,CR14 | 05335-80005 |
| A9CR6,CR7 | 1901-0050 |
| A9CR8,CR9,CR11,CR12 | 1901-1068 |
| A9CR10,CR13 | 1902-0551 |
| A9Q1 | 1854-0345 |
| A9U1 | 5088-7036 |
| A9U2 | 1820-2382 |
| A9U3 | 1820-1225 |
| A9U4 | 1826-0412 |
| A9U5 | 1820-1112 |

CONNECTOR PIN TABLES:

A9-A2 CONNECTIONS

| A9P1 | A2XA9 | DESCRIPTION |
|------|-------|------------------|
| 1 | 1 | GROUND |
| 2 | 2 | Enable |
| 3 | 3 | +15.7 Volts |
| 4 | 4 | Channel C Output |
| 5 | 5 | -5.2 Volts |
| 6 | 6 | Ground |
| 7 | 7 | N/C |
| 8 | 8 | N/C |
| 9 | 9 | N/C |
| 4 | 4 | +5 Volts |
| 5 | 5 | D6 |
| 6 | 6 | D7 |

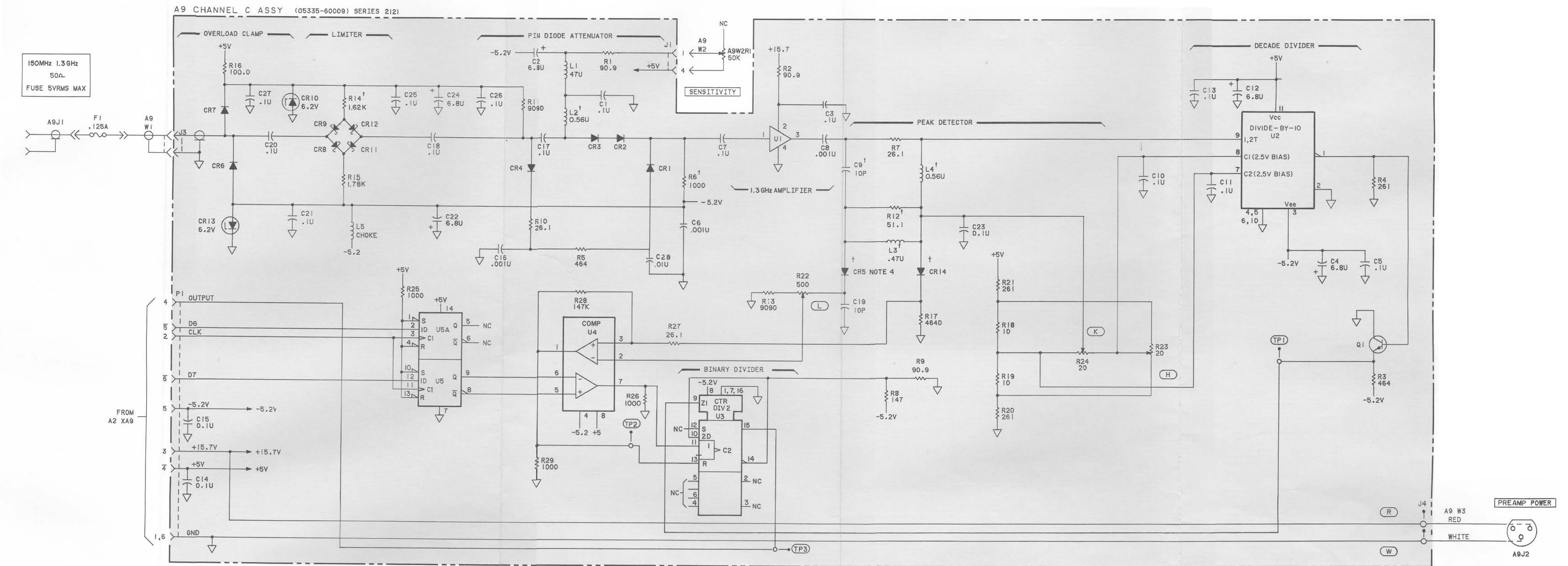
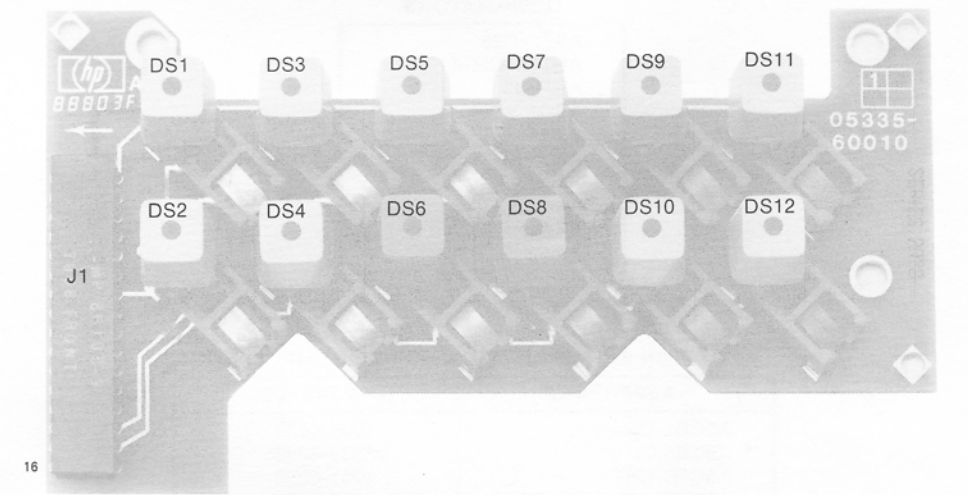

Figure 8-115. A9 Channel C (Option 030) Assembly



A10

Figure 8-115
A9 CHANNEL C (OPTION 030) ASSEMBLY

(See Page 8-121)

Part of Figure 8-116. A10 Switch Panel (Option 040) Assembly

NOTES

1. REFERENCE DESIGNATIONS WITHIN THIS ASSEMBLY ARE ABBREVIATED. ADD ASSEMBLY NUMBER TO ABBREVIATION FOR A COMPLETE REFERENCE DESIGNATION.

**A10
REFERENCE
DESIGNATORS**

| |
|-------------|
| A10DS1-DS12 |
| A10J1 |
| A10S1-S12 |

A10 OPTION 040 ACTIVE COMPONENTS

| REFERENCE | HP PART NO. |
|-------------|-------------|
| A10DS1-DS12 | 1990-0851 |

CONNECTOR PIN TABLES:

A10--A5 CONNECTIONS

| A10J1 | A5J2 | DESCRIPTION |
|-------|------|-------------|
| (1) | (1) | D6 |
| (2) | (2) | N/C |
| (3) | (3) | D7 |
| (4) | (4) | A5U2(2) |
| (5) | (5) | A5U2(26) |
| (6) | (6) | A5U2(4) |
| (7) | (7) | A5U2(24) |
| (8) | (8) | A5U2(20) |
| (9) | (9) | A5U2(21) |
| (10) | (10) | A5U2(22) |
| (11) | (11) | A5U3(1) |
| (12) | (12) | A5U3(4) |
| (13) | (13) | A5U3(6) |
| (14) | (14) | A5U3(2) |
| (15) | (15) | A5U3(3) |
| (16) | (16) | A5U3(5) |

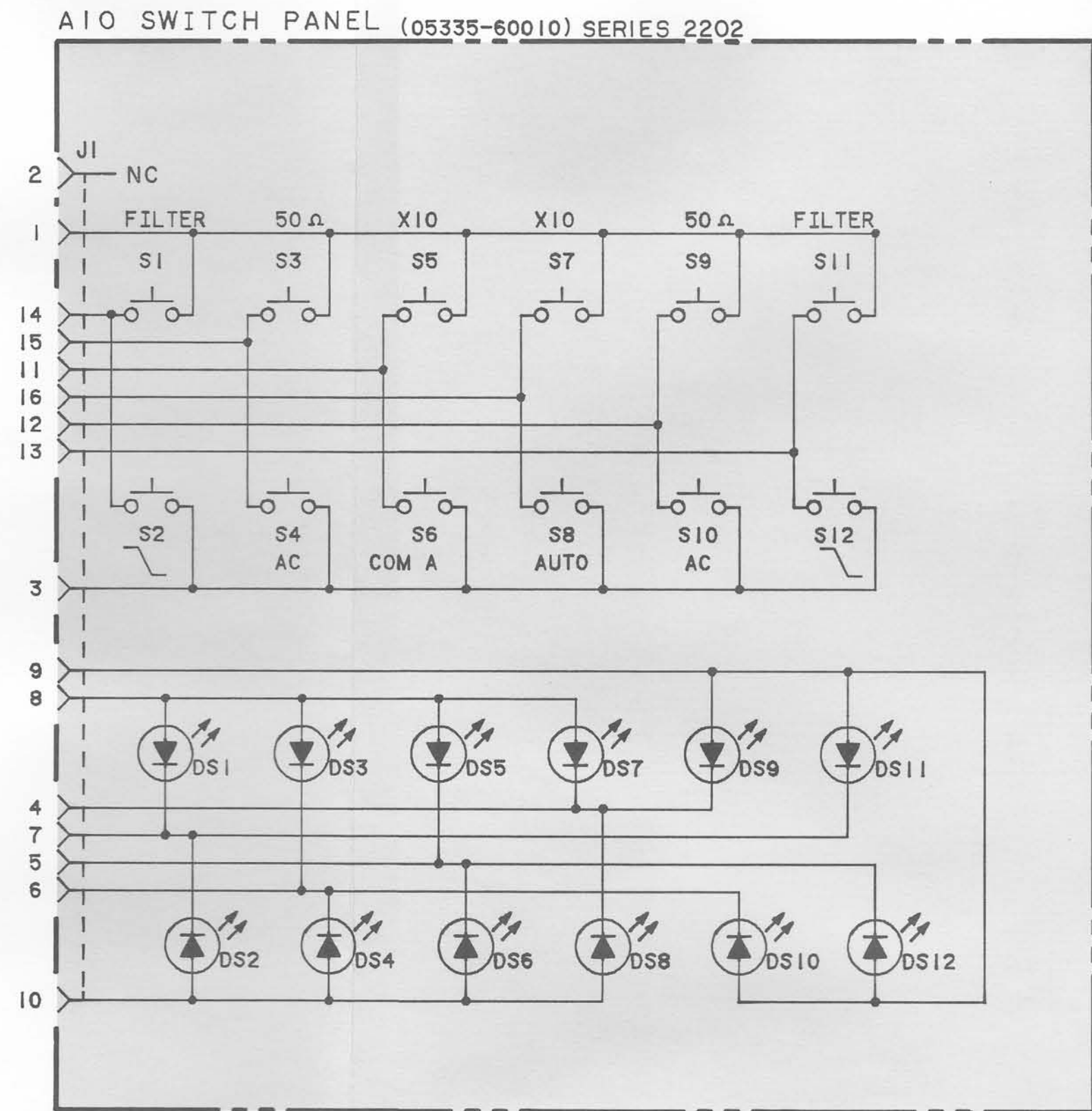
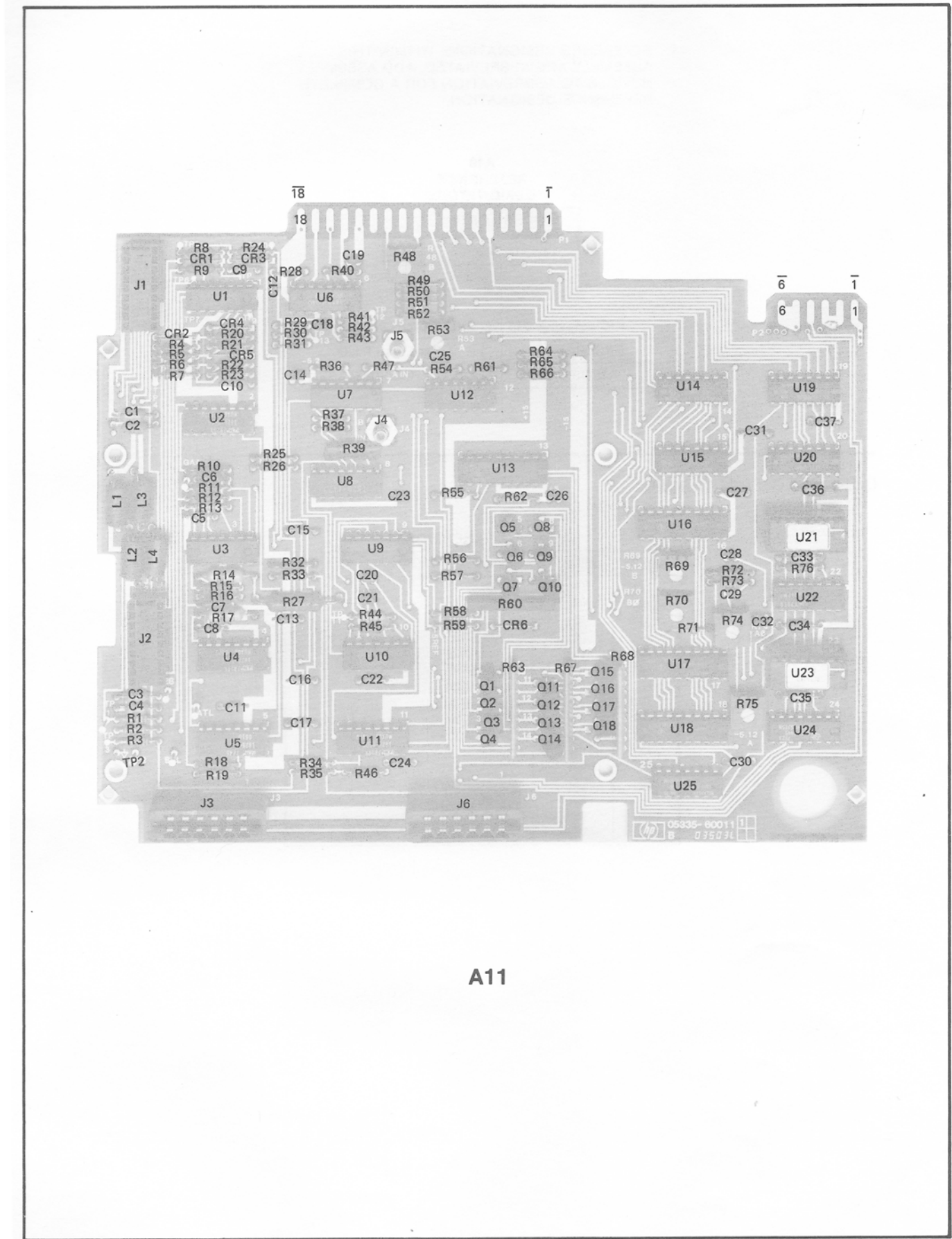

Figure 8-116. A10 Switch Panel (Option 040) Assembly



A11

Part of Figure 8-117. A11 Amplifier Support (Option 040) Assembly

Figure 8-116
A10 SWITCH PANEL (OPTION 040) ASSEMBLY

(See Page 8-123)

NOTES

1. REFERENCE DESIGNATIONS WITHIN THIS ASSEMBLY ARE ABBREVIATED. ADD ASSEMBLY NUMBER TO ABBREVIATION FOR A COMPLETE REFERENCE DESIGNATION.
2. UNLESS OTHERWISE INDICATED:
RESISTANCE IN OHMS
CAPACITANCE IN FARADS
INDUCTANCE IN HENRIES
3. ASTERISK (*) INDICATES FACTORY SELECTED COMPONENT VALUE. AVERAGE VALUE SHOWN. PART MAY NOT BE IN ALL INSTRUMENTS.

**A11
REFERENCE
DESIGNATORS**

| |
|------------|
| A11C1-C37 |
| A11CR1-CR6 |
| A11J1-J6 |
| A11L1-L4 |
| A11Q1-Q18 |
| A11R1-R76 |
| A11U1-U25 |

A11 OPTION 040 ACTIVE COMPONENTS

| REFERENCE | HP PART NO. |
|----------------|-------------|
| A11CR1,CR2 | 1901-0376 |
| A11CR3,CR5,CR6 | 1901-0050 |
| A11CR4 | 1902-3097 |
| A11Q1-Q9 | 1854-0246 |
| A11Q10-Q18 | 1853-0036 |
| A11U1,U3,U9 | 1826-0315 |
| A11U2,U4,U11 | 1826-0609 |
| A11U5 | 1826-0610 |
| A11U6 | 1858-0040 |
| A11U7 | 1820-1359 |
| A11U8 | 1820-1173 |
| A11U10 | 1826-0575 |
| A11U12 | 1820-0794 |
| A11U13 | 1820-1917 |
| A11U14,U15 | 1820-1196 |
| A11U16-U18 | 1820-1858 |
| A11U19,U20 | 1820-1240 |
| A11U21,U23 | 1820-1984 |
| A11U22 | 1826-0135 |
| A11U24 | 1820-1445 |
| A11U25 | 1820-1197 |

CONNECTOR PIN TABLES:

A11--A4 CONNECTIONS

| A11P1 | A4XA11 | DESCRIPTION |
|-------|--------|-------------|
| 1 | 1 | LAOE |
| 2 | 2 | NC |
| 3 | 3 | NC |
| 4 | 4 | NC |
| 5 | 5 | A3 |
| 6 | 6 | D7 |
| 7 | 7 | D5 |
| 8 | 8 | D3 |
| 9 | 9 | D1 |
| 10 | 10 | BTL |
| 11 | 11 | NC |
| 12 | 12 | ATL |
| 13 | 13 | NC |
| 14 | 14 | +3 Volts |
| 15 | 15 | CHB to MRC |
| 16 | 16 | +3 Volts |
| 17 | 17 | CHA to MRC |
| 18 | 18 | +3 Volts |
| A | A | L(VMAE) |
| B | B | NC |
| C | C | A2 |
| D | D | A1 |
| E | E | A0 |
| F | F | A6 |
| H | H | D4 |
| J | J | J2 |
| K | K | D0 |
| L | L | Ground |
| M | M | NC |
| N | N | NC |
| P | P | NC |
| R | R | +3 Volts |
| S | S | +3 Volts |
| T | T | +3 Volts |
| U | U | +3 Volts |
| V | V | +3 Volts |

A11--A1,A8,A9 CONNECTIONS

| A11J3 | A9P1 | DESCRIPTION |
|-------|------|---------------|
| 1 | 1 | GROUND |
| 2 | 2 | Enable |
| 3 | 3 | +15 Volts |
| 4 | 4 | "C" CH Output |
| 5 | 5 | -5.2 Volts |
| 6 | 6 | Ground |
| A | A | NC F1 |
| B | B | NC F2 |
| C | C | NC |
| D | D | +5 Volts |
| E | E | D6 |
| F | F | D7 |

| A11J6 | A8P1 | DESCRIPTION |
|-------|------|--------------------|
| 1 | 1 | GROUND |
| 2 | 2 | AC Supply |
| 3 | 3 | Enable |
| 4 | 4 | +5 Volts |
| 5 | 5 | Ground (Option IN) |
| 6 | 6 | Ground |
| A | A | DVM Output (Freq) |
| B | B | AC Supply |
| C | C | D5 |
| D | D | D6 |
| E | E | D7 |
| F | F | D4 |

| A11P2 | A1P1 | DESCRIPTION |
|-------|------|----------------------|
| 1 | 1 | +5 Volts |
| 2 | 2 | GROUND |
| 3 | 3 | GROUND |
| 4 | 4 | AC DVM Supply |
| 5 | 5 | GROUND |
| 6 | 6 | GROUND |
| A | A | +15 Volts |
| B | B | +10 Volts Reference) |
| C | C | +15 Volts |
| D | D | AC DVM Supply |
| E | E | GROUND |
| F | F | -5.2 Volts |

NOTES

CONNECTOR PIN TABLES (CONTINUED):

CONNECTIONS A11 to A12

| A11J1 | A12J7 | MNEMONIC | FUNCTION |
|--|--------------|----------|---|
| (1) | (1) | +5 | +5 Volt Supply |
| (2) | (2) | GND | GROUND RETURN |
| (3) | (3) | -5.2 | -5.2 Volt Supply |
| (4) | (4) | -15 | -15 Volt Supply |
| (5) | (5) | APR | "A" Preset Switch Status Preset = 1 |
| (6) | (6) | +15 | +15 Volt Supply |
| (7) | (7) | APD | "A" + Peak Det. Output |
| (8) | (8) | AND | "A" - Peak Det. Output |
| (9) | (9) | GND | GROUND RETURN |
| (10) | (10) | AAT | "A" Atten. Relay -12V/0V = X10/X1 |
| (11) | (11) | AAC | A AC Relay -12V/0V = AC/DC |
| (12) | (12) | A50 | A50 Ohm Relay -12V/0V = 50/1M |
| (13) | (13) | ANE | NEGATIVE ENABLE, A Peak Det. -13V/AUTO |
| (14) | (14) | APT | TRIGGER LEVEL POT A Channel |
| (15) | (15) | APE | Positive Enable A Peak Det. +13V/AUTO |
| (16) | (16) | ATL | Trigger Level to A Channel |
| (17) | (17) | GAA | ANALOG GROUND A Channel |
| (18) | (18) | AD | A Filter Relay -12V/0V = Filter ON/OFF |
| A11J2 | A12J2 | | |
| (1) | (1) | BND | B -Peak Det. Output |
| (2) | (2) | BPD | B +Peak Det. Output |
| (3) | (3) | +15 | +15 Volt Supply |
| (4) | (4) | BPR | B Preset Switch Status Preset = 1 |
| (5) | (5) | -15 | -15 Volt Supply |
| (6) | (6) | -5.2 | -5.2 Volt Supply |
| (7) | (7) | SEP | Common/Separate Relay -12V/0V = SEP/COM |
| (8) | (8) | +5 | +5 Volt Supply |
| (9) | (9) | BTL | TRIGGER LEVEL to B Channel |
| (10) | (10) | BNE | NEGATIVE ENABLE, B Peak Det. -13V/AUTO |
| (11) | (11) | BPT | TRIGGER LEVEL POT B Channel |
| (12) | (12) | BPE | POSITIVE ENABLE B Peak Det. +13V/AUTO |
| (13) | (13) | B50 | B50 Ohm Relay -12V/0V = 50/1M |
| (14) | (14) | BAT | B ATTEN Relay -12V/0V = X10/X1 |
| (15) | (15) | BAC | B AC Relay -12V/0V = AC/DC |
| (16) | (16) | BF | B Filter Relay -12V/0V = Filter ON/OFF |
| (17) | (17) | GAB | ANALOG GROUND B Channel |
| (18) | (18) | GND | GROUND RETURN |
| A11J5 to A12J4 A Channel Output A11J4 to A12J8 B Channel Output | | | |

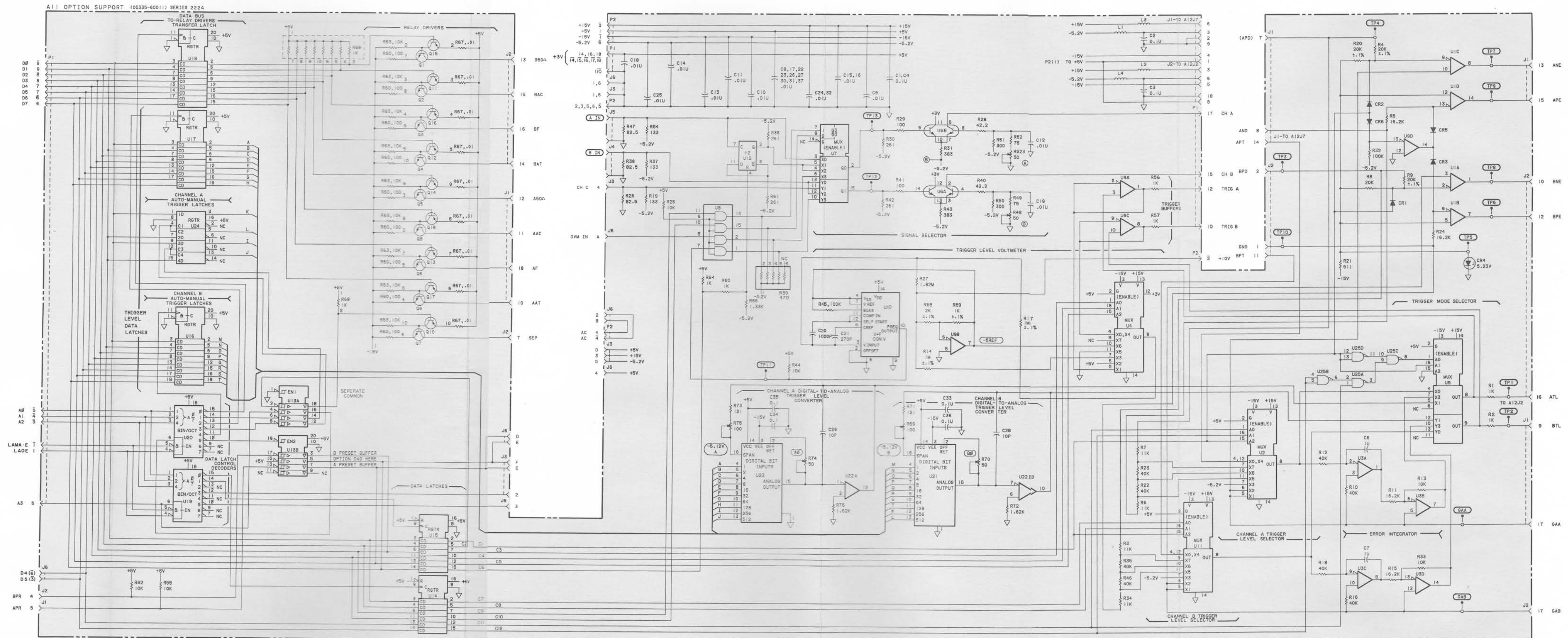
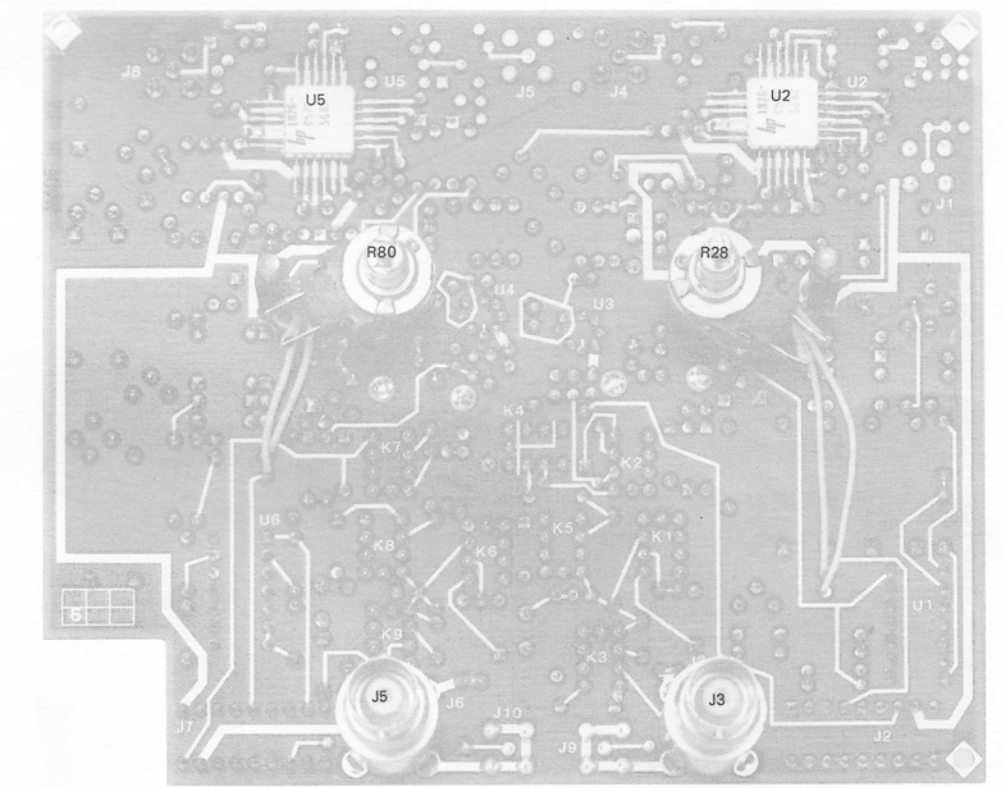

Figure 8-117. A11 Amplifier Support (Option 040) Assembly



Figure 8-117
A11 AMPLIFIER SUPPORT (OPTION 040) ASSEMBLY

(See Page 8-127)



A12

Part of Figure 8-118. A12 Programmable Input Amplifier (Option 040) Assembly

NOTES

- REFERENCE DESIGNATIONS WITHIN THIS ASSEMBLY ARE ABBREVIATED. ADD ASSEMBLY NUMBER TO ABBREVIATION FOR A COMPLETE REFERENCE DESIGNATION.
- UNLESS OTHERWISE INDICATED:
RESISTANCE IN OHMS
CAPACITANCE IN FARADS
INDUCTANCE IN HENRIES
- ASTERISK (*) INDICATES FACTORY SELECTED COMPONENT VALUE. AVERAGE VALUE SHOWN. PART MAY NOT BE IN ALL INSTRUMENTS.
- MATCHED SETS OF DIODES: CR2,6,7; CR3,8,9; CR4,5,10,11; CR25,26,29,30; CR31,32,36; CR33,34,37.
- R7, R8, R100 & R106 ALTERNATE VALUE IS 3.16M.
- PIN CONNECTION FOR ACTIVE ELEMENTS:

BOTTOM VIEWS

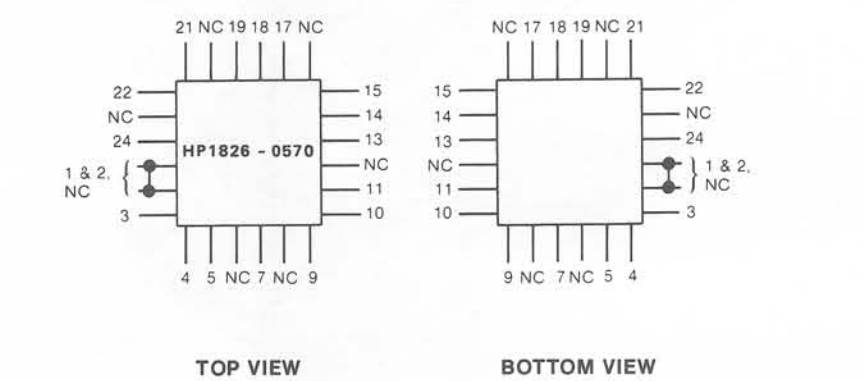
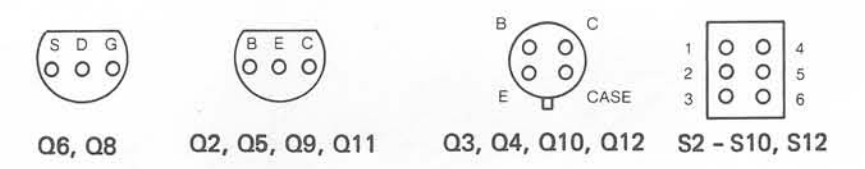

A12 OPTION 040 ACTIVE COMPONENTS

| REFERENCE | HP PART NO. |
|---------------------------|------------------------|
| A12CR1, CR22 | 1901-1080 |
| A12CR2, CR6, CR7 | 05335-80003* |
| A12CR3, CR8, CR9 | 05335-80003* |
| A12CR4, CR5, CR10, CR11 | 05335-80003* |
| A12CR12, CR35 | 1902-0057 |
| A12CR13, CR27 | 1902-0041 |
| A12CR14, CR16-CR20, | |
| A12CR23, CR24, CR28 | 1901-0050 |
| A12CR15, CR21 | 1902-3136 |
| A12CR25, CR26, CR29, CR30 | 05335-80003* |
| A12CR31, CR32, CR36 | 05335-80003* |
| A12CR33, CR34, CR37 | 05335-80003* |
| A12Q, Q5, Q9, Q11 | 1854-0636 |
| A12Q3, Q4, Q10, Q12 | 1854-0686 |
| A12Q6, Q8 | 1855-0212 or 1855-0300 |
| A12U1, U8 | 1826-0600 |
| A12U2, U5 | 1826-0570 |
| A12U3, U4 | 1826-0035 |

*Matched Set of Four Diodes

NOTES

CONNECTOR PIN TABLES:

| CONNECTIONS A12 to A11 | | | |
|------------------------|-------|----------|--|
| A12J7 | A11J1 | MNEMONIC | FUNCTION |
| (1) | (1) | +5 | +5 Volt Supply |
| (2) | (2) | GND | GROUND RETURN |
| (3) | (3) | -5.2 | -5.2 Volt Supply |
| (4) | (4) | -15 | -15 Volt Supply |
| (5) | (5) | APR | "A" Preset Switch Status Preset = 1 |
| (6) | (6) | +15 | +15 Volt Supply |
| (7) | (7) | APD | "A" + Peak Det. Output |
| (8) | (8) | AND | "A" - Peak Det. Output |
| (9) | (9) | GND | GROUND RETURN |
| (10) | (10) | AAT | "A" Atten. Relay -12V/0V = X10/X1 |
| (11) | (11) | AAC | A AC Relay -12V/0V = AC/DC |
| (12) | (12) | A50 | A50 Ohm Relay -12V/0V = 50/1M |
| (13) | (13) | ANE | NEGATIVE ENABLE, A Peak Det. -13V/AUTO |
| (14) | (14) | APT | TRIGGER LEVEL POT A Channel |
| (15) | (15) | APE | Positive Enable A Peak Det. +13V/AUTO |
| (16) | (16) | ATL | Trigger Level to A Channel |
| (17) | (17) | GAA | ANALOG GROUND A Channel |
| (18) | (18) | AD | A Filter Relay -12V/0V = Filter ON/OFF |

| A12J2 | A11J2 | MNEMONIC | FUNCTION |
|-------|-------|----------|---|
| (1) | (1) | BND | B -Peak Det. Output |
| (2) | (2) | BPD | B +Peak Det. Output |
| (3) | (3) | +15 | +15 Volt Supply |
| (4) | (4) | BPR | B Preset Switch Status Preset = 1 |
| (5) | (5) | -15 | -15 Volt Supply |
| (6) | (6) | -5.2 | -5.2 Volt Supply |
| (7) | (7) | SEP | Common/Separate Relay -12V/0V = SEP/COM |
| (8) | (8) | +5 | +5 Volt Supply |
| (9) | (9) | BTL | TRIGGER LEVEL to B Channel |
| (10) | (10) | BNE | NEGATIVE ENABLE, B Peak Det. -13V/AUTO |
| (11) | (11) | BPT | TRIGGER LEVEL POT B Channel |
| (12) | (12) | BPE | POSITIVE ENABLE B Peak Det. +13V/AUTO |
| (13) | (13) | B50 | B50 Ohm Relay -12V/0V = 50/1M |
| (14) | (14) | BAT | B ATTEN Relay -12V/0V = X10/X1 |
| (15) | (15) | BAC | B AC Relay -12V/0V = AC/DC |
| (16) | (16) | BF | B Filter Relay -12V/0V = Filter ON/OFF |
| (17) | (17) | GAB | ANALOG GROUND B Channel |
| (18) | (18) | GND | GROUND RETURN |

A11J5 to A12J4 A Channel Output
A11J4 to A12J8 B Channel Output

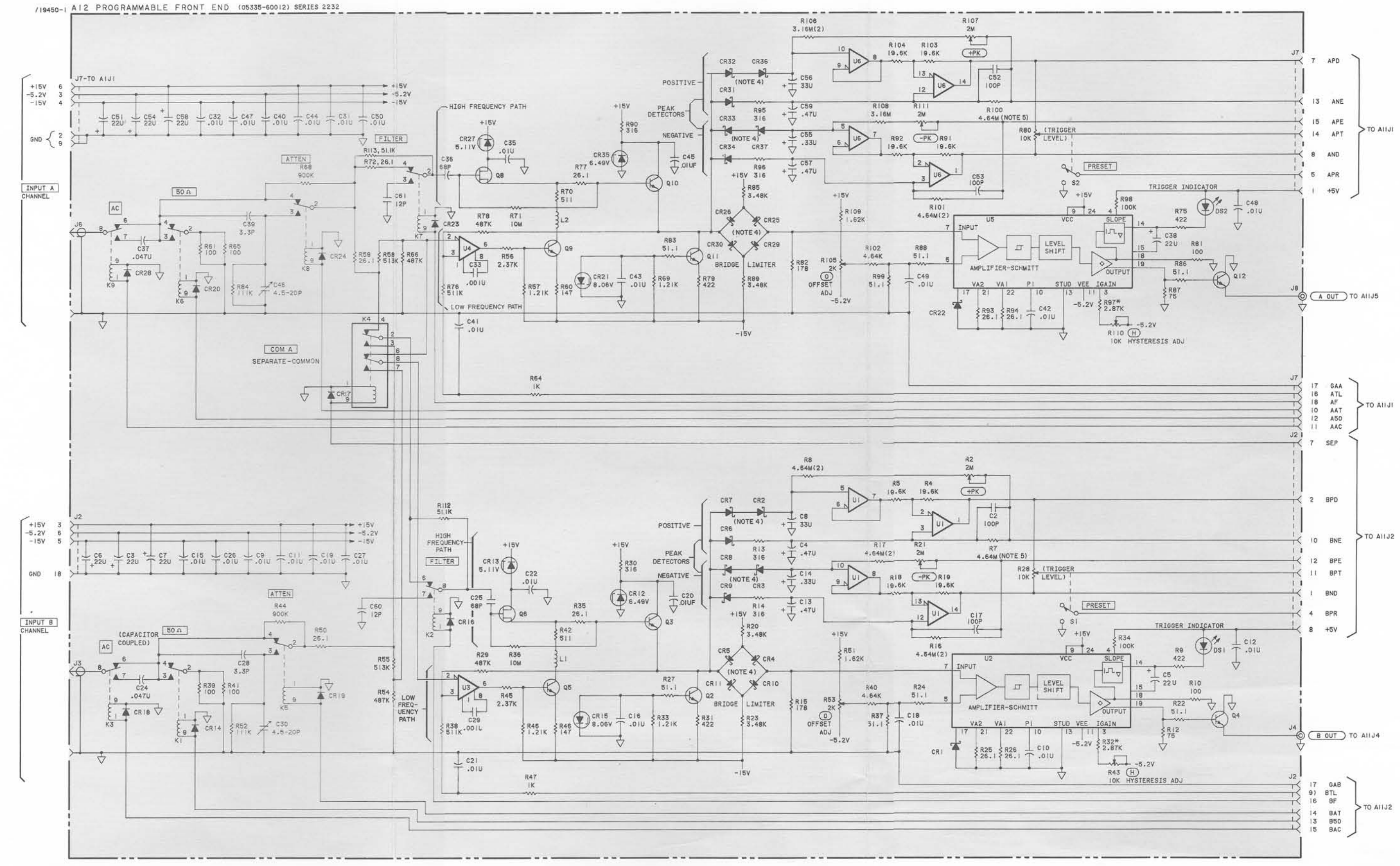
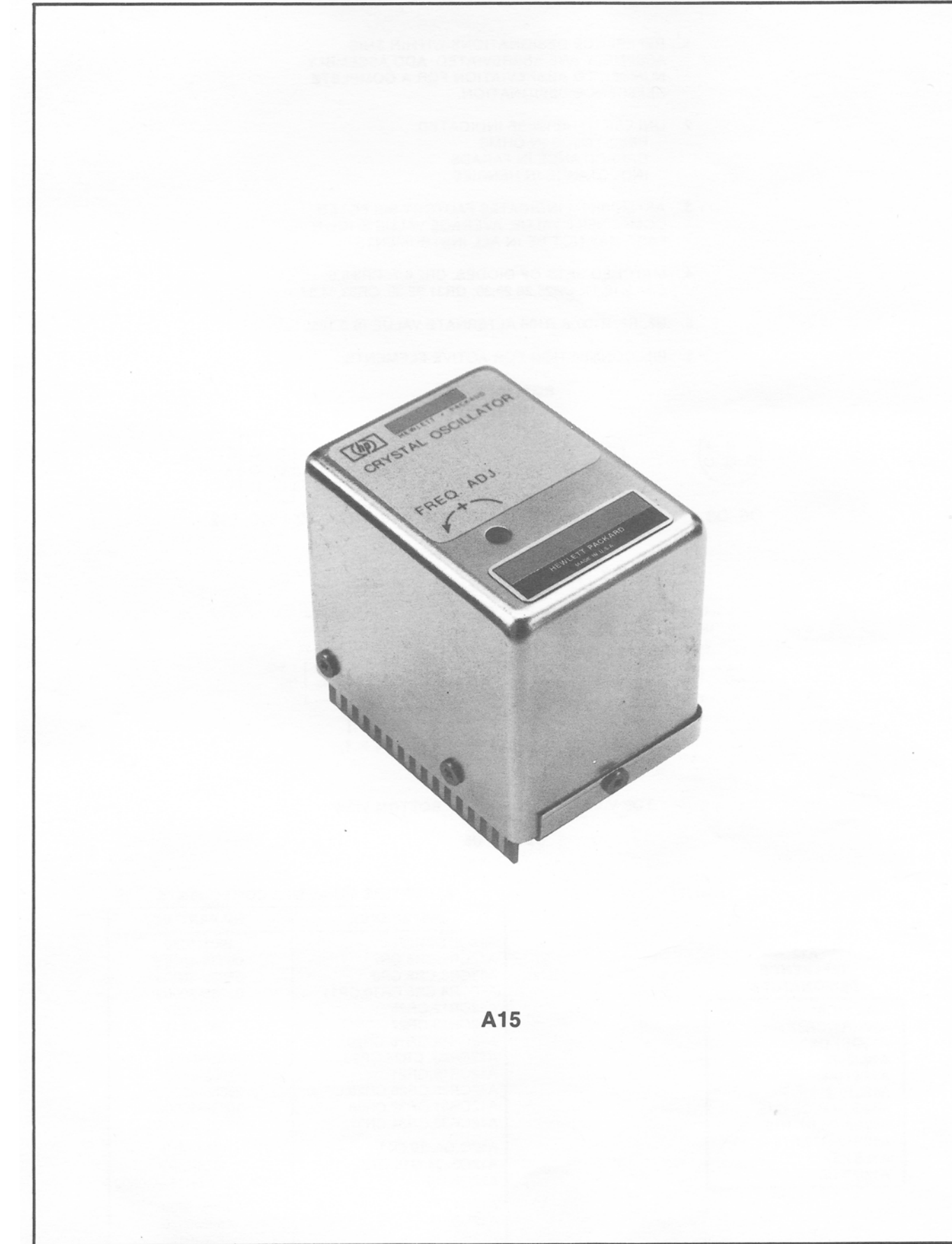

Figure 8-118. A12 Programmable Input Amplifier (Option 040) Assembly

Figure 8-118
A12 PROGRAMMABLE INPUT AMPLIFIER (OPTION 040) ASSEMBLY
(See Page 8-129)



A15

Part of Figure 8-119. A15 10 MHz Oscillator (Option 010)

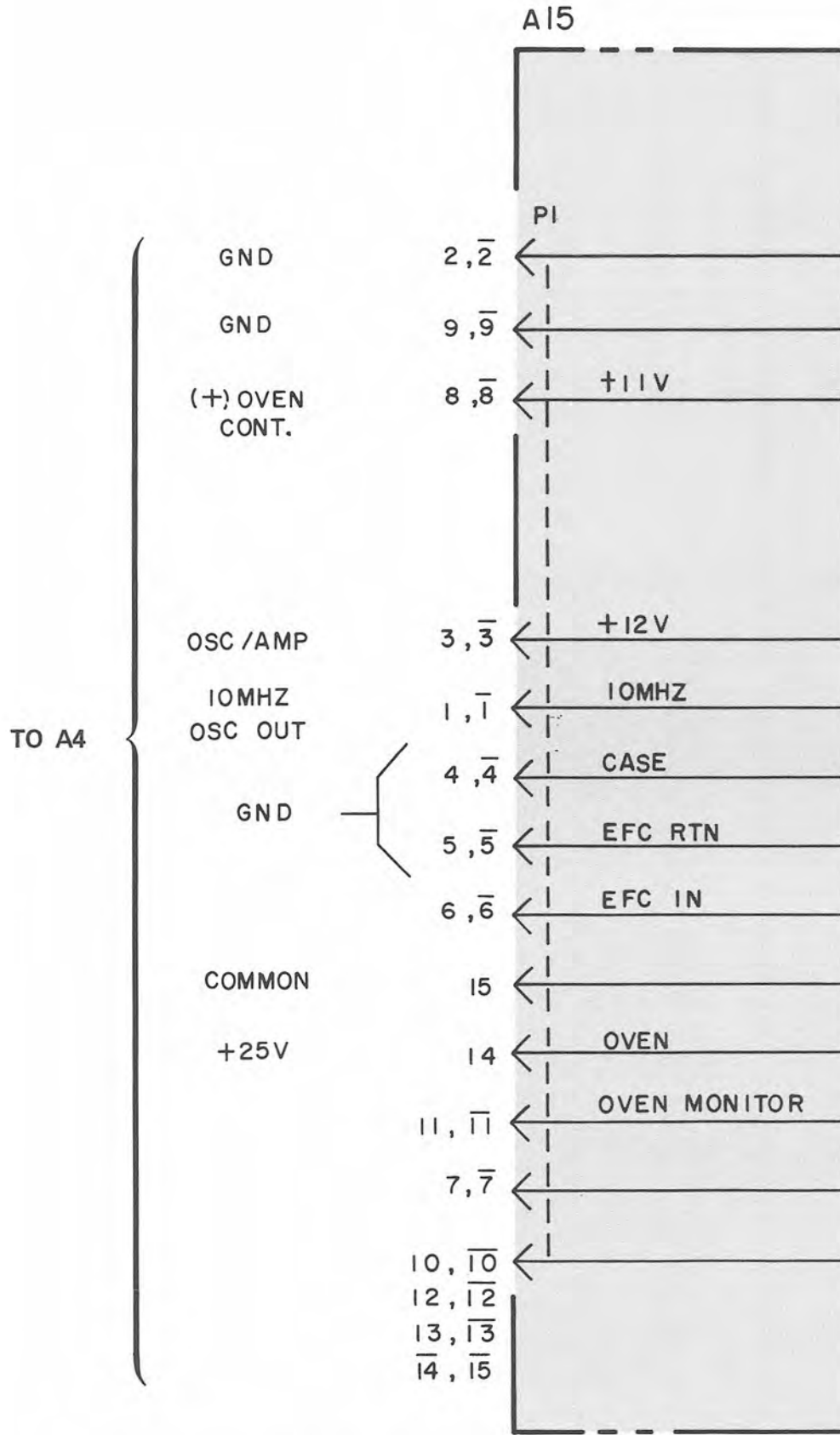

Figure 8-119. A15 10 MHz Oscillator (Option 010) Assembly

NOTES

CONNECTOR PIN TABLES:

A16P1 Connections

| PIN # | DESCRIPTION | PIN # | DESCRIPTION |
|-------|---------------|-------|---------------------|
| 1 | A1 | 1 | A0 |
| 2 | A3 | 2 | A2 |
| 3 | A5 | 3 | A4 |
| 4 | A7 | 4 | A6 |
| 5 | A9 | 5 | A8 |
| 6 | A11 | 6 | A10 |
| 7 | A13 | 7 | A12 |
| 8 | RESET | 8 | A14 |
| 9 | CLOCK (1 MHz) | 9 | N/C |
| 10 | N/C | 10 | SA-MEM ENABLE (GND) |
| 11 | VMA | 11 | LVMA-E |
| 12 | R/W | 12 | START/STOP (A15) |
| 13 | GND | 13 | N/C |
| 14 | +5 VOLTS | 14 | N/C |
| 15 | D1 | 15 | D0 |
| 16 | D3 | 16 | D2 |
| 17 | D5 | 17 | D4 |
| 18 | D7 | 18 | D6 |

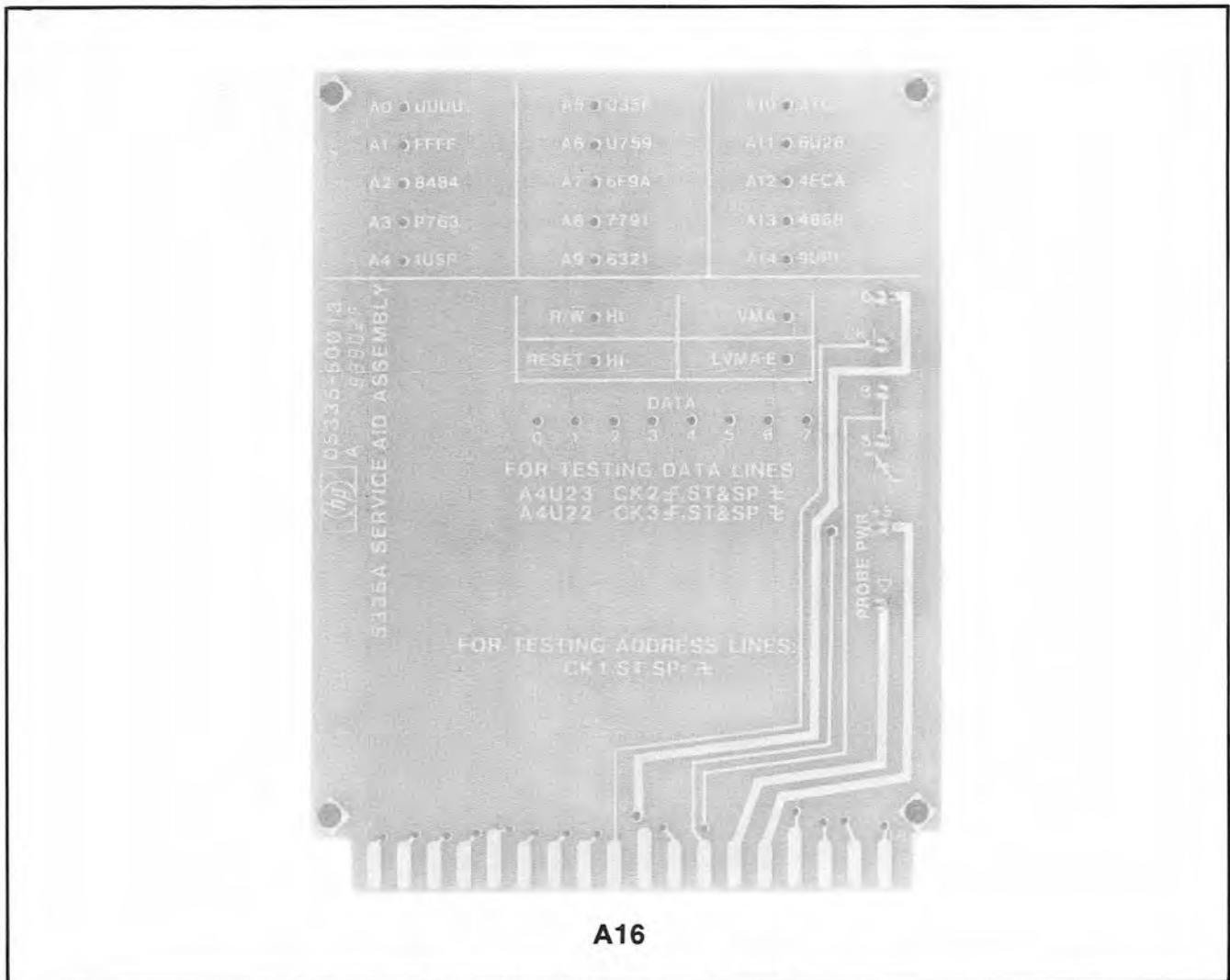

A16

Figure 8-120. A16 Service Aid Board

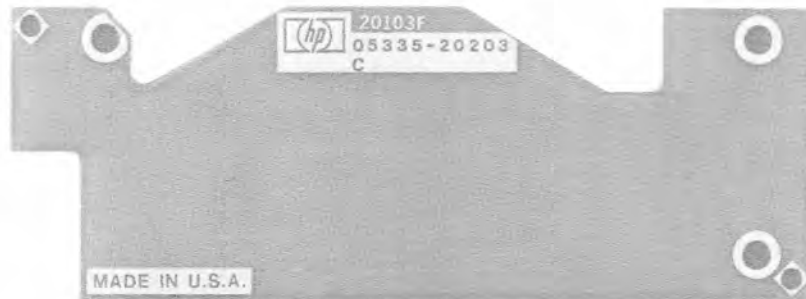

A17

Figure 8-121. A17 Shield Board (Option 040)